

—  —  
**BARBER  
LINE**  
Industrias Oriol

**Besondere  
friseur  
Speciale per  
parrucchieri**

*Keine Preise / Senza Prezzi*



EURO *stil*  
PROFESSIONAL

RAGNAR  
BARBER LINE



**FEATHER®**

Musol

**DERBY®**



**ELIOS**

pen RAZOR® by MAGIA

CLIPP-AID

BERGMANN

 **INDUSTRIAS  
ORIOL** 1942 S.L.U.  
PELUQUERÍA · BARBERÍA · ESTÉTICA · COSMÉTICA

[www.eurostil.com](http://www.eurostil.com)

## 01 Elektrogeräte Barber e accessori 4

RAGNAR Schneidemaschinen · <i>Tagliacapelli RAGNAR</i> .....	5
CAPTAIN COOK Schneidemaschinen .....	12
<i>Tagliacapelli CAPTAIN COOK</i> .....	
EUROSTIL Schneidemaschinen .....	14
<i>Tagliacapelli EUROSTIL</i> .....	
RAGNAR Retuschiermaschine .....	16
<i>Tagliacapelli da rifinitura RAGNAR</i> .....	
CAPTAIN COOK Retuschiermaschine .....	17
<i>Tagliacapelli da rifinitura CAPTAIN COOK</i> .....	
RAGNAR 360° Retuschiermaschine .....	20
<i>360° Tagliacapelli da rifinitura RAGNAR</i> .....	
CAPTAIN COOK 360° Retuschiermaschine .....	21
<i>360° Tagliacapelli da rifinitura CAPTAIN COOK</i> .....	
RAGNAR Rasierer, BARBER LINE Rasierer .....	22
CAPTAIN COOK Rasierer .....	
<i>Rasoio RAGNAR, Rasoio BARBER LINE, Rasoio CAPTAIN COOK</i> .....	
Nasentrimmer · <i>Tagliapeli</i> .....	25
Zubehör für Schneidemaschinen (Öle) .....	26
<i>Accessori per macchine da taglio (oli)</i> .....	
Föhn, Glätteisen- und Wachs Fixierer .....	28
<i>Asciugacapelli, piastra e scaldacera</i> .....	
Haarstaubsauger · <i>Hair Vacuum</i> .....	32
Sterilisatoren · <i>Sterilizzatori</i> .....	33

## 02 Rasiermesser und rasierklingen 36

RAGNAR Rasiermesser · <i>Rasoi RAGNAR</i> .....	37
BARBER LINE Rasiermesser · <i>Rasoi BARBER LINE</i> .....	39
CAPTAIN COOK Rasiermesser · <i>Rasoi CAPTAIN COOK</i> .....	43
EUROSTIL Rasiermesser · <i>Rasoi EUROSTIL</i> .....	45
FEATHER Rasiermesser und ihre Klingen .....	46
<i>Rasoi FEATHER e le loro lame</i> .....	
Rasierklingen · <i>Lame</i> .....	47
Einweg-Rasierer · <i>Rasoi usa e getta</i> .....	48
Pen razor, Rasierschaum und Rasiergel .....	51
<i>Pen razor, Schiume e Gel</i> .....	

## 03 Scheren 52

RAGNAR-Scheren · <i>Forbici RAGNAR</i> .....	53
CAPTAIN COOK-Scheren · <i>Forbici CAPTAIN COOK</i> .....	56
BARBER LINE-Scheren · <i>Forbici BARBER LINE</i> .....	59
EUROSTIL-Scheren · <i>Forbici EUROSTIL</i> .....	60
Azubi Scheren · <i>Forbici per studenti</i> .....	62
Spezielle Scheren für Linkshänder .....	63
<i>Forbici speciali per mancini</i> .....	

## 04 Bürsten und pinsel 64

Bartbürsten · <i>Pennelli da barba</i> .....	65
Talkum · <i>Talco</i> .....	67
BARBER LINE / RAGNAR-Bürsten .....	68
<i>Pennelli BARBER LINE / RAGNAR</i> .....	
EUROSTIL-Bürsten .....	72
<i>Spazzole EUROSTIL</i> .....	
CAPTAIN COOK Bürsten .....	73
<i>Spazzole CAPTAIN COOK</i> .....	

## 05 Kämmе 74

RAGNAR Kämmе · <i>Pettini RAGNAR</i> .....	75
CAPTAIN COOK Kämmе · <i>Pettini CAPTAIN COOK</i> .....	79
BARBER LINE Kämmе · <i>Pettini BARBER LINE</i> .....	81
EUROSTIL Kämmе · <i>EUROSTIL Pettini</i> .....	82
Carbon Kämmе · <i>Pettini in carbonio</i> .....	83
SILKOMB Kämmе · <i>SILKOMB Pettini</i> .....	84
Kamm mit Wasserwage und Kammreiniger .....	85
<i>Pettine a bola, e pulisci pettini</i> .....	

## 06 Kosmetik 86

RAGNAR .....	87
CAPTAIN COOK .....	88
THE SHAVING CO .....	95
MR. BEAR FAMILY .....	99
OSMA .....	101
MYRSOL .....	102
LEGEND .....	106
TASSEL .....	107

## 07 Möbel und dekoration 110

Barberpole · <i>Polo barber</i> .....	111
Barbierstuhl · <i>Poltrone</i> .....	112
Wachbecken · <i>Poltrone lavatesta</i> .....	117
Kinderstühle · <i>Poltrone per bambini</i> .....	119
Spiege · <i>Specchi</i> .....	121
Arbeitswagen und Tonnen · <i>Carrelli</i> .....	122
Empfangtheke und anderes .....	123
<i>Bancone reception e altri</i> .....	

## 08 Zubehör 128

Nackpapier · <i>Carla collo</i> .....	129
Umkleideraum · <i>Abbigliamento</i> .....	132
LACLA Umkleideraum .....	138
<i>Abbigliamento LACLA</i> .....	
Sprühflasche · <i>Spruzzatore</i> .....	142
Koffer · <i>Valigie</i> .....	146
Handtuch · <i>Salviette</i> .....	148
Handtücher · <i>Asciugamani</i> .....	150
Desinfektionsmittel, Sterilisatoren, Spiegel, Besen .....	153
<i>Disinfettanti, Sterilizzanti, Specchi E Scope</i> .....	

## 09 Ausbildung 160

Trainingsköpfe EUROSTIL .....	161
<i>Teste studio EUROSTIL</i> .....	
Trainingsköpfe BARBER LINE .....	162
<i>Teste studio BARBER LINE</i> .....	
Ständer und Stative · <i>Supporti e treppiedi</i> .....	163

Die in diesem Katalog aufgeführten Preise sind empfohlene Preise, Steuern nicht inbegriffen.  
Die Preise gelten bis auf Tippfehler.  
Industrias Oriol 1942, S.L. behält sich das Recht vor, Änderungen ohne vorherige Ankündigung  
vorzunehmen.

*I prezzi indicati in questo catalogo sono prezzi consigliati ,iva esclusa.  
I prezzi saranno validi salvo errori tipografici.  
Industrias Oriol 1942, S.L. si riserva il diritto di apportare modifiche senza preavviso.*

# THUNDER

## MÁQUINA CORTE RECARGABLE

Máquina de corte recargable THUNDER de "Captain Cook", diseñada para el uso del profesional. Mayor potencia y de larga duración, súper silencioso y de baja vibración. Fabricada con materiales de alta calidad y de última generación.



# THUNDER

## HAIR CLIPPER RECHARGEABLE



# 01

## Elektrogeräte Barber e Accessori

*Schneide- und Trimm Apparate,  
Rasierapparate, Trockner, Nasenhaartrimmer,  
Glätteisen, Fixierapparate...*

*Tagliacapelli, rasoi, asciugacapelli,  
tagliapel, piastre per la barba, scaldacera...*







*Kraft, Qualität,  
eleganz und design  
Potenza, qualità,  
eleganza e design*



**RAGNAR**  
BARBER LINE

## Haarschneider GALAXY FADING Tagliacapelli GALAXY FADING

**RAGNAR**  
BARBER LINE

u.m.vta: 1  12 

REF. 07220



*Spezial Fade  
Special Fade*

- Bereit zum Verlassen
- Ohne Klängenregelhebel
- Feste Klinge einstellbar auf 0,2 - 0,3
- Spannung: 100-240 V~
- Frequenz: 50/60 Hz
- Leistung: 8 W
- 5500 rpm (+/-100)
- Abbaugrad: 0,2 - 0,3 mm
- Rasierklinge aus japanischem Stahl
- Feste Rasierklinge aus Titan
- Reinigungsbürste
- Dose Schmieröl
- Schutzbezug Rasierklinge
- Netzteil
- LCD-Multifunktions-Anzeige

- Pronto per dissolvenza
- Senza leva di regolazione della lama
- Lama fissa regolabile a 0,2 - 0,3
- Voltaggio: 100-240V~
- Frequenza: 50/60Hz
- Potenza: 8W.
- 5500 r.p.m. (+/-100)
- Grado di sfumatura: 0,2 - 0,3 mm
- Lama in acciaio giapponese
- Lama fissa in titanio
- Pennellino per la pulizia.
- Contenitore olio lubrificante
- Protezione lama
- Display LCD multifunzione

### Ersatzteile · Ricambi

#### Klinge · Lama

REF.07389





SCAN  
ME!



## Haarschneider GALAXY CERAMIC Tagliacapelli GALAXY CERAMIC

Ideal für lange Arbeitszeiten  
Ideale per lavorare lunghe ore

u.m.vta: 1  12 

REF. 07221



### *Keramikklinge.*

Reduziert die erwärmung der klinge

### *Lama in ceramica*

Riduce il riscaldamento della lama

- Spannung: 100-240 V~
- Frequenz: 50/60 Hz
- Leistung: 8 W
- 5500 rpm (+/-100)
- Abbaugrad: 0,5 mm
- Hebel zum Einstellen der Rasierklinge
- RASIERKLINGE AUS KERAMIK und feste Rasierklinge aus Titan
- 6 Käämme, anpassbar (1.5, 3, 4.5, 6, 10 und 13 mm).
- Reinigungsbürste
- Dose Schmieröl
- Schutzbezug Rasierklinge
- Netzteil
- LCD-Multifunktions-Anzeige
- Rasierklinge aus Keramik

- Voltaggio: 100-240V~
- Frequenza: 50/60Hz
- Potenza: 8W.
- 5500 r.p.m. (+/-100)
- Grado di sfumatura: 0,5mm
- Leva di regolazione
- LAMA IN CERAMICA e lama fissa in titanio.
- 6 rialzi (1,5 - 3,4,5,6,10 e 13 mm)
- Pennellino per la pulizia.
- Olio lubrificante
- Protezione lama
- Display LCD multifunzione
- Lama in ceramica

### Ersatzteile · Ricambi

#### Klinge · Lama

REF.07388



Mehr  
Informationen  
Maggiori  
informazioni

SCAN  
ME!



**Tagliacapelli GALAXY**  
GALAXY hair clipper

**RAGNAR**  
BARBER LINE



Ragnar  
GALAXY  
06714

SCAN  
ME!





Ragnar  
GALAXY  
06714/50

SCAN  
ME!





u.m.vta: 1  

REF. 06714

REF. 06714/50



- Hebel zur Klingeneinstellung
- Klinge aus japanischem Stahl
- 6 Adapter Aufsätze (1,5, 3, 4,5, 6, 10 und 13 mm)
- Schmierölbehälter
- Reinigungsbürste
- Klingenschutz
- Netzteil
- Multifunktions-LCD-Anzeige
- Maximale Leistung: 8 W
- Spannung: 100-240 V~
- Frequenz: 50/60 Hz
- Umdrehungen pro Minute: 5500+/-100 U/min
- Abbaugrad: 0,5 mm

- Leva di regolazione della lama
- Lama in acciaio giapponese
- 6 rialzi (1,5 - 3,4,5,6,10 e 13 mm mm)
- Contenitore olio lubrificante
- Pennellino per la pulizia
- Protezione lama
- Display LCD multifunzione
- Potenza massima: 8 W.
- Voltaggio: 100-240 V~
- Frequenza: 50/60 Hz
- Giri al minuto: 5500 +/- 100 rpm
- Grado di sfumatura: 0,5mm

### Kämme · Rialzi

### Ersatzteile · Ricambi

1,5 mm REF. RE06985/01	3 mm REF. RE06985/02	4,5 mm REF. RE06985/03
6 mm REF. RE06985/04	10 mm REF. RE06985/05	13 mm REF. RE06985/06



### Klinge · Lama

Flach Piatta REF. 06983	Standard Standard REF. 06984
-------------------------------	------------------------------------



### Pack 6 Metallklingen · Confezione di 6 dialzi in metallo

REF. 06985



**Tagliacapelli SUPERNOVA**  
*SUPERNOVA hair clipper*



**RAGNAR**  
BARBER LINE



*Sie wollen  
mehr wissen?  
Vuoi sapere  
di più?*

**SCAN  
ME!**



u.m.vta: 1  

REF. 06715

REF. 06715/50



- Hebel zur Klingeneinstellung
- Klinge aus japanischem Stahl
- 6 Adapter Aufsätze (1,5, 3, 4,5, 6, 10, 13 mm)
- Schmierölbehälter
- Reinigungsbürste
- Klingenschutz
- Netzteil
- Turbo-Funktion
- Multifunktions-LCD-Anzeige
- Maximale Leistung: 8 W
- Spannung: 100-240 V~
- Frequenz: 50/60 Hz
- Umdrehungen pro Minute: 5500+/-100 U/min
- Turbo: 5700/-100 U/min
- Abbaugrad: 0,5 mm

- Leva di regolazione della lama
- Lama in acciaio giapponese
- 6 rialzi (1,5 - 3,4,5,6,10 e 13 mm mm)
- Contenitore olio lubrificante
- Pennellino per la pulizia
- Protezione lama
- Funzione turbo
- Display LCD multifunzione
- Potenza massima: 8 W.
- Voltaggio: 100-240 V~
- Frequenza: 50/60 Hz
- Giri al minuto: 5500 +/- 100 rpm
- Turbo: 5700/-100 rpm
- Grado di sfumatura: 0,5mm

### Kämme · Rialzi

### Ersatzteile · Ricambi

1,5 mm REF. RE06985/01	3 mm REF. RE06985/02	4,5 mm REF. RE06985/03
6 mm REF. RE06985/04	10 mm REF. RE06985/05	13 mm REF. RE06985/06



### Klinge · Lama

Flach Piatta REF. 06983	Standard Standard REF. 06984
-------------------------------	------------------------------------



### Pack 6 Metallklingen · Confezione di 6 dialzi in metallo

REF. 06985



## Schneidemaschine EAGLE

### Tagliacapelli a filo eagle

u.m.vta: 1  6 

REF. 06390



- Mit Kabel 2,5 m
- Enthält 6 Metallkämme und 2 Klingen
- Mit japanischen Stahlklingen
- Spannung: 220-240 V~
- Frequenz: 50 Hz
- Maximale Leistung: 10 W
- Umdrehungen pro Minute: 6500+/-800 U/min
- Geeignet für alle natürlichen Haartypen
- Abbaugrad: 0,5 mm

- Con cavo da 2,5 m
- Include 6 rialzi in metallo e 2 lame
- Lame in acciaio giapponese
- Voltaggio: 220-240 V~
- Frequenza: 50 Hz
- Potenza massima: 10 W.
- Giri al minuto: 6500+/-800 rpm
- Adatto a qualsiasi tipo di capello naturale
- Grado di sfumatura: 0,5mm

## Schneidemaschine FALCON

### Tagliacapelli FALCON

u.m.vta: 1  6 

REF. 06391



- Ohne Kabel
- Enthält 6 Metallkämme und 2 Klingen
- Mit japanischen Stahlklingen
- Spannung: 100-240 V~
- Frequenz: 50/60 Hz
- Maximale Leistung: 5 W
- Umdrehungen pro Minute: 5500+/-800 U/min
- Adapter-Eingang: 0,2 A
- Ausgang des Adapters: 5V 600mA
- Geeignet für alle natürlichen Haartypen
- Abbaugrad: 0,5 mm

- Senza cavo
- Include 6 rialzi in metallo e 2 lame
- Lame in acciaio giapponese
- Voltaggio: 100-240 V~
- Frequenza: 50/60 Hz
- Potenza massima: 5 W.
- Giri al minuto: 5500+/-800 rpm
- Ingresso trasformatore: 0,2 A
- Uscita trasformatore: 5V 600mA
- Adatto a qualsiasi tipo di capello naturale
- Grado di sfumatura: 0,5mm

**Ersatzteile · Ricambi****Kämme · Rialzi**

1,5 mm

REF. RE06602/01

3 mm

REF. RE06602/02

4,5 mm

REF. RE06602/03

6 mm

REF. RE06602/04

10 mm

REF. RE06602/05

13 mm

REF. RE06602/06

**Klinge · Lama**

Standard

Standard

REF. 06603

REF. 07327



Flach

Piatta

REF. 06604

REF. 07326

**Pack 6 Metallklingen · Confezione di 6 dialzi in metallo**

REF. 06602

Kompatibel mit 06390, 06391, 06666  
 Compatibile con 06390, 06391, 06666



## Schneidemaschine K-3600 Tagliacapelli K-3600

u.m.vta: 1 20

REF. 03752

REF. 03752/50



SCAN  
ME!

- Leistung: 5 W
- Spannung: 200-240 V~
- Frequenz 50 Hz
- Ausgang des Adapters: 3V ~500 mA
- Zubehör: 4 Käme
- Keramischer Schneidkopf mit einstellbarer Bewegung in der Schnittgröße
- Feste Klinge aus Titan
- Stromversorgungskabel
- 2 wiederaufladbare Batterien
- Reinigungsbürste
- Schmieröl-Flasche

- Potenza: 5 W.
- Voltaggio: 200-240 V~
- Frequenza 50 Hz
- Uscita trasformatore: 3V ~ 500 mA
- Accessori: 4 rialzi
- Testina di taglio in ceramica con movimento regolabile per la misura del taglio
- Lama fissa in titanio
- 2 batterie ricaricabili
- Pennellino per la pulizia
- Olio lubrificante



Arbeitszeit 60/90 min  
Autonomia 60/90 min



Mit Batterie oder elektrischen  
Strom verwendbar  
E' possibile utilizzarlo  
con batteira, o con filo



5h Ladezeit  
5 ore tempo di ricarica



Keramikkopf  
und Titanklinge  
Testina in ceramica  
e lama in titanio



### Kämme · Rialzi

### Ersatzteile · Ricambi

3 mm  
REF. RE03752/07

6 mm  
REF. RE03752/08

9 mm  
REF. RE03752/09

12 mm  
REF. RE03752/10



3 mm



6 mm



9 mm



12 mm

### Aufsatz · Testina

REF. RE03752/01

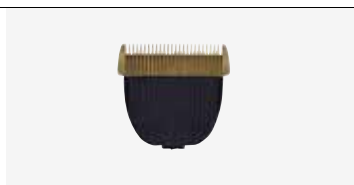

### Batterie · Batteria

REF. RE03752/03



## Schneidemaschine K-3000

### Tagliacapelli K-3000

u.m.vta: 1 20

REF. 03753



SCAN ME!

- Leistung: 3 W
- Klingen; 8, 30 und 40 mm.
- Mit Aufsätzen für Nase/Ohren und Rasur
- Auswechselbare Messer leicht zu reinigen
- Niedrige Schwingung, sehr leise
- LED Ladenanzeiger
- Bis 60 min Betriebsdauer
- Einstellbare Schnittlänge mit 4 Stufen; 3,6,9 u.12 mm

- Potenza: 3 W.
- Rialzi 8 mm, 30 mm, 40 mm per dettagli, testina naso/orecchie e testina di barba
- Lama intercambiabile facile da pulire
- Vibrazioni ridotte e molto silenziosa
- Indicatore di carica a LED
- Carica a lunga durata, fino a 60 minuti di autonomia
- Lunghezza di taglio regolabile 4 livelli: 3mm, 6mm, 9mm e 12mm



Professionelle  
Haarschneidemaschine  
zum Trimmen von Bart-,  
Nasen- und Ohrenhaaren

Tagliacapelli  
professionale per ritocchi  
a barba, naso e orecchie



### Aufsatz · Testina

### Ersatzteile · Ricambi

Nasenaufsatz  
Per il naso

Rasieraufsatz  
Per la barba

REF. RE03753/07

REF. RE03753/08

8 mm

30 mm

40 mm

REF. RE03753/06

REF. RE03753/04

REF. RE03753/05



8 mm



30 mm



40 mm





### Kämme · Rialzis

REF. RE03753/01



## COSMIC-Trimmer Tagliacapelli COSMIC

**RAGNAR**  
BARBER LINE

u.m.vta: 1  20 



REF. 06713



REF. 06713/50



- 38-mm-Schneidkopf
- Feste Klinge aus rostfreiem Stahl
- Schnittgrößen-Adapter Aufsätze (2,3 und 4 mm)
- Reinigungsbürste
- Schmierölbehälter
- Stromversorgungskabel
- Ein/Aus-Taste
- Multifunktions-LCD-Anzeige
- Maximale Leistung: 5 W
- Spannung: 100-240 V~
- Frequenz: 50/60 Hz
- Umdrehungen pro Minute: 5500+/-100 U/min

- Testina di taglio da 38 mm
- Lama fissa in acciaio inossidabile.
- Rialzi (2,3 e 4 mm)
- Spazzola per la pulizia
- Olio lubrificante
- Cavo di alimentazione
- Pulsante di accensione e spegnimento
- Display LCD multifunzione
- Potenza massima: 5 W.
- Voltaggio: 100-240 V~
- Frequenza: 50/60 Hz
- Giri al minuto: 5500 +/- 100 rpm



SCAN  
ME!



### Kämme · Rialzi

2 mm

REF. RE06713/01

3 mm

REF. RE06713/02

4 mm

REF. RE06713/03

2 mm



3 mm



4 mm



### Ersatzteile · Ricambi

### Klinge · Lama

REF.06982

Trimmer T-Null  
Trimmer T-zero







## TRIUMPH Trimmer

### Tagliacapelli da rifinitura TRIUMPH

u.m.vta: 1 6

REF. 06667



- Ohne Kabel
- 38-mm-Schneidekopf
- Feste Klinge aus rostfreiem Stahl
- Adapterkamm für Schnittgröße (1,2 und 3 mm)
- Pack 6 Metallkämme
- Reinigungsbürste
- Schmierölbehälter
- Stromversorgungskabel
- **LADESTATION**
- Ein/Aus-Taste
- Maximale Leistung: 10W
- Spannung: 100-240V~
- Frequenz: 50/60Hz
- Umdrehungen pro Minute: 5500+/-800 U/min
- Abbaugrad: 0,1 mm

- Senza cavo
- Testina di taglio da 38 mm
- Lama fissa in acciaio inossidabile.
- Adattatore a pettine per regolazione del taglio (1,2 e 3 mm)
- Confezione di 6 rialzi in metallo
- Pennellino per la pulizia
- Olio lubrificante
- **BASE DI RICARICA**
- Pulsante ON-OFF
- Potenza massima: 10W.
- Voltaggio: 100-240V~
- Frequenza: 50/60Hz
- Giri al minuto: 5500+/-800 rpm
- Grado di sfumatura: 0,1mm



SCAN ME!

*Neu*  
Mit ladestation

*Novità*  
Con base per ricarica

### Kämme · Rialzi

### Ersatzteile · Ricambi

1 mm

REF. RE06667/05



2 mm

REF. RE06667/06

3 mm

REF. RE06667/07

1 mm

2 mm

3 mm



### Klinge · Lama



REF. RE06667/01

Mit Stellschrauben  
Con viti regolabili



## THUNDER Trimmer

### Taglia capelli da rifinitura THUNDER

u.m.vta: 1  6 

REF. 06666



- Hebel zur Klingeneinstellung
- 2 japanische Stahlklingen
- 6 Adapter Aufsätze (1,5, 3, 4,5, 6, 10, 12 mm)
- Reinigungsbürste
- Schmierölbehälter
- Klingenschutz
- Maximale Leistung: 10W
- Spannung: 100-240V~
- Frequenz: 50/60Hz
- Umdrehungen pro Minute: 5500+/-800 U/min
- Abbaugrad: 0,5 mm
- **LADEGERÄT**

- Leva di regolazione della lama
- 2 lame in acciaio giapponese
- 6 rialzi (1,5, 3, 4,5, 6, 10, 12 mm).
- Pennellino per la pulizia
- Olio lubrificante
- Protezione lama
- Potenza massima: 10W.
- Voltaggio: 100-240V~
- Frequenza: 50/60Hz
- Giri al minuto: 5500+/-800 rpm
- Grado di sfumatura: 0,5mm
- **BASE DI RICARICA**



*Neu*  
Mit ladestation

*Novità*  
Con base per ricarica

**Ersatzteile · Ricambi**

**pag. 423**



**Pack Nr. 1 "5. Jahrestag" CAPTAIN COOK**  
**Pack n°1 "5° Anniversario" CAPTAIN COOK**

u.m.vta: 1 1

REF. 07276

**Enthält:**

- Bürste Fade - 04977
- Effilierschere Black Ripper 6" - 06479
- Haarschneider Thunder - 06666
- Necessaire Captain Cook - 07079

**Contiene:**

- Spazzola Fade - 04977
- Forbici black ripper per scopire 6" - 06479
- Tagliacapelli Thunder - 06666
- Borsa da toilette Captain Cook - 07079



**Pack Nr. 2 "5. Jahrestag" CAPTAIN COOK**  
**Pack n°2 "5° Anniversario" CAPTAIN COOK**

u.m.vta: 1 1

REF. 07330

**Enthält:**

- Haarschneider Thiumph - 06667
- Bürste Fade - 04977
- Effilierschere Black Ripper 6" - 06479
- Necessaire Captain Cook - 07079



**Contiene:**

- Tagliacapelli Thriumph - 06667
- Spazzola Fade - 04977
- Forbici per scolpire 6" Black ripper - 06479
- Borsa da toilette Captain Cook - 07079



## Haartrimmer AIRFLIP

### Taglia capelli da rifinitura AIRFLIP

 u.m.vta: 1  6  

REF. 07282



- Spannung: 100-240 V~
- Frequenz: 50/60 Hz
- Leistung: 8 W
- 6500 rpm (+/-500)
- Schneidkopf von 38 mm
- Schutzbezug für Rasierklinge.
- Feste Rasierklinge aus Edelstahl
- Kamm-Adapter für das Schnittmaß (1, 2 und 3 mm)
- Reinigungsbürste
- Dose Schmieröl
- Netzkabel
- **LADEGERÄT**
- Transparenter Deckel
- Abbaugrad: 0,1 mm

- **Voltaggio: 100-240V~**
- **Frequenza: 50/60Hz**
- **Potenza: 8W.**
- **6500 r.p.m. (+/-500)**
- **Testina di taglio da 38 mm**
- **Protezione lama**
- **Lama fissa in acciaio inossidabile.**
- **Rialzi (1,2 e 3mm)**
- **Pennellino per la pulizia.**
- **Contenitore olio lubrificante**
- **BASE DI RICARICA.**
- **Grado di sfumatura: 0,1mm**

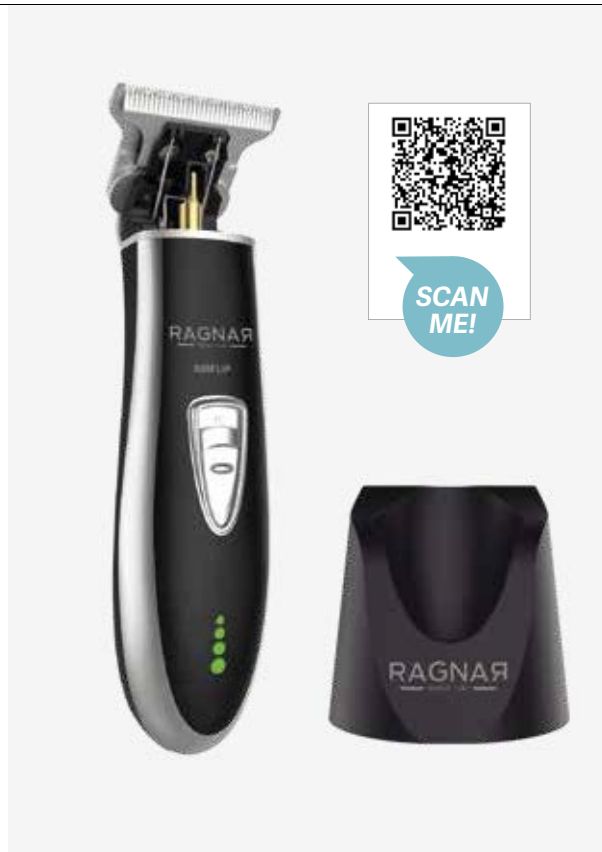
 Ansicht Schnitt der Rasierklinge  
 Visione taglio

### Kämme · Rialzi

1 mm

REF. RE07282/01

2 mm

REF. RE07282/02

3 mm

REF. RE07282/03



### Ersatzteile · Ricambi

1 mm

2 mm

3 mm



### Klinge · Lama

REF.07324



## Haartrimmer DRAKE

### Taglia capelli da rifinitura DRAKE



u.m.vta: 1 20

REF. 07283



- Spannung: 100-240 V~
- Frequenz: 50/60 Hz
- Leistung: 8 W
- 7000+/-500 rpm
- Schneidkopf von 38 mm
- Feste Rasierklinge aus Edelstahl
- Kamm-Adapter für Schnittmaß (1, 2 und 3 mm).
- Reinigungsbürste
- Dose Schmieröl
- Netzkabel
- Transparenter Deckel
- Abbaugrad: 0,1 mm

- Voltaggio: 100-240V~
- Frequenza: 50/60Hz
- Potenza: 8W.
- 7000+/-500 rpm.
- Testina di taglio da 38 mm.
- Lama fissa in acciaio inossidabile.
- Rialzi (1,2 e 3mm)
- Pennellino per la pulizia
- Olio lubrificante
- Grado di sfumatura: 0,1mm



SCAN  
ME!



Ansicht Schnitt der Rasierklinge  
Visione taglio



**Klinge · Lama**



**Ersatzteile · Ricambi**

REF.07325



## COMET-Rasierer COMET

**RAGNAR**  
BARBER LINE

 u.m.vta: 1  20 

REF. 07084/50

REF. 07084/54

 SCAN  
ME!

Vielen Dank, dass Sie sich für unseren neuen wiederaufladbaren Bartrasierer COMET 07084/50 - 07084/54 von "RAGNAR" entschieden haben, der für den professionellen Einsatz konzipiert ist. Leistungsstarker und langlebiger Motor, superleise und vibrationsarm. Hergestellt aus qualitativ hochwertigen Materialien und der letzten Generation.

- Spannung: 100-240V~
- Frequenz: 50/60Hz
- Leistung : 5W
- Umdrehungen pro Minute: 8.000-9.000 U/min
- Adapter-Eingang: : 0,2 A
- Ausgang des Adapters: 5V 1000mA
- Aufladezeit: 3 Stunden
- Betriebsdauer: mehr als 80 Minuten
- Lithium-Batterie
- Geeignet für alle natürlichen Haartypen
- Ideale Umgebungsbedingungen für den Einsatz:  
Verwendung in Innenräumen
- Temperatur -5° bis 40°C
- Relative Luftfeuchtigkeit gleich oder weniger als 80



*Grazie per aver scelto il nostro nuovo rasoio ricaricabile COMET 07084/50 - 07084/54 di RAGNAR progettato per un uso professionale. Motore potente e di lunga durata, super silenzioso e a basse vibrazioni. Realizzato con materiali di alta qualità e di ultima generazione.*

- Voltaggio: 100-240V~
- Frequenza: 50/60Hz
- Potenza: 5W.
- Giri al minuto: 8.000/9.000 rpm
- Ingresso trasformatore: : 0,2 A
- Uscita trasformatore: 5V 1000mA
- Tempo di ricarica: Tre ore
- autonomia: piu di 80 minuti
- Batteria al litio
- Adatto a qualsiasi tipo di capello naturale
- Condizioni ambientali ideali per l'uso: uso interno
- Temperatura da -5° a 40°C
- Umidità relativa uguale o inferiore all'80%



### Kompletter Aufsatz mit Klinge Testina completa con lama

Ersatzteile · Ricambi

 u.m.vta: 1  100 

REF. RE07084/50/01



REF. RE07084/54/01



## Bucanero-Rasierer

### Rasoio elettrico Bucanero

Barber Line

u.m.vta: 1  24 

REF. 06412/50

BUCANERO Bart-Rasierer, mit wiederaufladbarer "Barber Line"-Batterie, konzipiert für den professionellen Einsatz. Leistungsstarker und langlebiger Motor, superleise und vibrationsarm. Hergestellt aus qualitativ hochwertigen Materialien und der letzten Generation.

- Spannung: 100-220 V~
- Frequenz: 50/60 Hz
- Leistung: 3 W
- Umdrehungen pro Minute: 6800 U/min
- Adapter-Eingang: 3-5 W
- Leistung des Adapters: 2 W
- Aufladezeit: 2 Stunden
- Betriebsdauer: mehr als 90 Minuten
- Lithium-Batterie
- Geeignet für alle natürlichen Haartypen

Rasoio per barba BUCANERO, con batteria ricaricabile di "Barber Line", progettato per uso professionale. Motore potente e di lunga durata, super silenzioso e a basse vibrazioni. Realizzato con materiali di alta qualità e di ultima generazione.

- Voltaggio: 100-220 V~
- Frequenza: 50/60 Hz
- Potenza: 3 W.
- Giri al minuto: 6800 rpm
- Ingresso trasformatore: 3-5 W
- Uscita trasformatore: 2 W.
- Tempo di ricarica: 2 ore
- Autonomia: più di 90 minuti
- Batteria al litio
- Adatto a qualsiasi tipo di capello naturale





SCAN ME!



## Kompletter Aufsatz mit Klinge

### Testina completa con lama

Ersatzteile · Ricambi

u.m.vta: 1  12 



REF. RE06412/01

REF. RE06412/50/01



## Roadster-Rasierer

### Rasoio elettrico Roadster

u.m.vta: 1  12 

REF. 06411

ROADSTER Bart-Rasierer, mit wiederaufladbarer Batterie "Captain Cook", konzipiert für den professionellen Einsatz. Leistungsstarker und langlebiger Motor, superleise und vibrationsarm. Hergestellt aus qualitativ hochwertigen Materialien und der letzten Generation.

- Spannung: 100-220 V~
- Frequenz: 50/60 Hz
- Leistung: 3 W
- Umdrehungen pro Minute: 6800 U/min
- Adapter-Eingang: 3-5 W
- Leistung des Adapters: 2 W
- Aufladezeit: 2 Stunden
- Betriebsdauer: mehr als 90 Minuten
- Lithium-Batterie
- Geeignet für alle natürlichen Haartypen



*Rasoio per barba ROADSTER, con batteria ricaricabile di "Captain Cook", progettato per uso professionale. Motore potente e di lunga durata, super silenzioso e a basse vibrazioni. Realizzato con materiali di alta qualità e di ultima generazione.*

- Voltaggio: 100-220 V~
- Frequenza: 50/60 Hz
- Potenza: 3 W.
- Giri al minuto: 6800 rpm
- Ingresso trasformatore: 3-5 W
- Uscita trasformatore: 2 W.
- Tempo di ricarica: 2 ore
- Autonomia: più di 90 minuti
- Batteria al litio
- Adatto a qualsiasi tipo di capello naturale



## Kompletter Aufsatz mit Klinge

### Testina completa con lama

u.m.vta: 1  12 

REF. RE06411/01

Ersatzteile · Ricambi





**Eurostil Nasentrimmer**  
**Tagliapeli Eurostil**

Batterie nicht enthalten  
Batteria non inclusa

**EURO**  
*stil*  
PROFESSIONAL

u.m.vta: 1  100 

**REF. 04268**

- Kann nass werden
- Mit Sockel und 2 Zubehörteilen

- *Può entrare in contatto con l'acqua*
- *Con base e 2 accessori*



**REF. 04269**

- Kann nicht nass werden
- *Non può entrare in contatto con l'acqua*



**Trimmer**  
**Tagliapeli per ritocchi**

Batterie nicht enthalten  
Batteria non inclusa

u.m.vta: 1  100 

**REF. 04270**



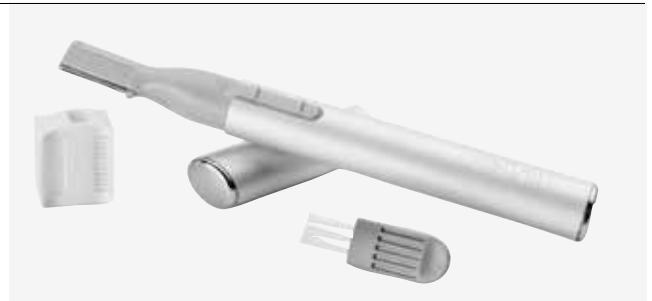

- Ergonomische Gestaltung
- Sanft zu empfindlicher Haut
- Ein/Aus-Schalter
- 2 Schnittebenen: für 2 mm Länge / für 5 mm Länge
- Schutzkappe
- Abgewinkelter Kopf für einfache Bedienung
- Netzteil
- 1 AAA-Batterie (nicht enthalten)



- *Batteria non inclusa*
- *Design ergonomico*
- *Delicato sulla pelle sensibile*
- *Interruttore on/off*
- *2 livelli di taglio: per 2 mm di lunghezza / per 5 mm di lunghezza*
- *Coperchio di protezione*
- *Testina angolata per un facile utilizzo*
- *Alimentazione elettrica*
- *1 batteria AAA (non inclusa)*

## Maschinenöl

### Olio per tagliacapelli

u.m.vta: 1  12 

Intensives Parfüm  
Profumo intenso

500 ml

REF. 06272

**RAGNAR**  
BARBER LINE



500 ml

Sanftes Parfüm  
Profumo delicato

REF. 06395





500 ml

Maschinenöl für den professionellen Einsatz. Kältemittel, desinfizierend, Schmiermittel und Antioxidationsmittel. Unverzichtbar für eine optimale Wartung der Klingen. Sprühen Sie in einem Abstand von ca. 15-20 cm seitlich auf den oberen Aufsatz.

Olio per tagliacapelli ad uso professionale. Refrigerante, igienizzante, lubrificante e antiossidante. Indispensabile per una manutenzione ottimale della lama. Spruzzare a una distanza di circa 15-20 cm dalla parte superiore della testina di taglio.

## Flasche Öl

### Flacone di olio lubrificante

u.m.vta: 1  10 

Zum schmieren  
Lubrificante

100 ml

REF. 03751

Bei diesem Spezialöl für Schneidemaschinen der Marke Eurostil handelt es sich um ein leichtes Mineralöl, das die Hubzeit der Klinge und damit den Schnitt der Klinge verbessert. Nicht irritierend.

Questo olio speciale per macchine da taglio di Eurostil è un olio minerale leggero che migliora i tempi di movimento della lama, migliorando così il taglio. Non irrita



100 ml

**Fussmatte für friseursalons RAGNAR**  
**Tappetino barber RAGNAR**

Material: Gummi  
 Materiale: Gomma

u.m.vta: 1  5

REF. 07386



**Fussmatte für friseursalons CAPTAIN COOK**  
**Tappetino barber CAPTAIN COOK**



Material: Gummi  
 Materiale: Gomma

u.m.vta: 1  5

REF. 07387



## KOMPAKTER PROFESSIONAL trockner Asciugacapelli COMPACT PROFESSIONAL

u.m.vta: 1  6 

REF. 04202



Wollen  
mehr wissen?  
Volere  
saperne di più?

SCAN  
ME!

*Leistungsstarker Motor  
mit Ionengenerator*

*Motore potente  
con generatore di ioni*







Der Profi-Trockner Compact hat ein attraktives, ergonomisches und leichtes Design. Erhältlich in schwarz, weiß und weiß mit farbigen Gummi. Leistungsstarker Motor mit Ionengenerator. Enthält zwei Düsen unterschiedlicher Größe.

L'asciugacapelli professionale Compact ha un design accattivante, ergonomico e leggero. Disponibile in nero, bianco e bianco con guarnizioni colorate. Motore potente con generatore di ioni. Include due bocchette di dimensioni diverse.

- Leistung: 2000W
- Kompakter AC-Motor mit langer Lebensdauer
- Gewicht: 580 g
- Luftdurchsatz: 90 m<sup>3</sup>/Stunde
- 2 Geschwindigkeiten, 3 Temperaturen
- Kaltluft-Knopf
- 2 einstellbare Düsen von 62 mm und 70 mm
- Herausnehmbarer Filter
- Sicherheitsthermostat
- Flexibles Kabel 3m mit Ring zum Aufhängen
- Niedriger Geräuschpegel
- Spannung 220-240V~
- Frequenz: 50/60 Hz
- Ergonomische Gestaltung
- Robustes und leichtes Polyamid-Gehäuse
- Anti-Rutsch-Gummibesatz
- Ionengenerator-Motor
- Kompatibel mit Diffusoren: 04346/50 - 01147 - 03036/50

- Potenza: 2000W.
- Motore compatto di lunga durata AC
- Peso: 580 g
- Portata d'aria: 90 m<sup>3</sup>/ora
- 2 velocità, 3 temperature
- Pulsante aria fredda
- 2 bocchette regolabili da 62mm e 70mm
- Filtro rimovibile
- Termostato di sicurezza
- Cavo flessibile 3m
- Silenzioso
- Voltaggio 220-240V~
- Frequenza: 50/60 Hz
- Design ergonomico
- Corpo in poliammide robusto e leggero
- Rivestimento in gomma antiscivolo
- Motore generatore di ioni
- Compatibile con diffusori: 04346/50 - 01147 - 03036/50

## KOMPAKTER EXTRA-LICHT-Trockner Asciugacapelli COMPACT EXTRA LIGHT

u.m.vta: 1  6 u.m.vta: 1  12 

REF. 04203



REF. 04203/58



Der Profi-Trockner Compact hat ein attraktives, ergonomisches und leichtes Design. Erhältlich in schwarz, weiß und weiß mit farbigen Gummi. Leistungsstarker Motor mit Ionengenerator. Enthält zwei Düsen unterschiedlicher Größe.

- Leistung: 1800W
- Gleichstrommotor
- Gewicht: 430 g
- Luftdurchsatz: 76 m<sup>3</sup>/Stunde
- 2 Geschwindigkeiten, 3 Temperaturen
- Kaltluft-Knopf
- 2 einstellbare Düsen von 62 mm und 70 mm
- Herausnehmbarer Filter
- Sicherheitsthermostat
- Flexibles Kabel 3m mit Ring zum Aufhängen
- Sehr niedriger Geräuschpegel
- Spannung 220-240V~
- Frequenz: 50/60 Hz.
- Kompakt und LEICHTER
- Anti-Rutsch-Gummibesatz
- Mit Ionengenerator
- Kompatibel mit Diffusoren: 04346/50 - 01147 - 03036/50



L'asciugacapelli professionale Compact ha un design accattivante, ergonomico e leggero. Disponibile in nero, bianco e bianco con guarnizioni colorate. Motore potente con generatore di ioni. Include due bocchette di dimensioni diverse.

- Potenza: 1800W.
- Motore DC
- Peso: 430 g
- Portata d'aria: 76 m<sup>3</sup>/ora
- 2 velocità, 3 temperature
- Pulsante aria fredda
- 2 bocchette regolabili da 62mm e 70mm
- Filtro rimovibile
- Termostato di sicurezza
- Cavo flessibile 3m
- Impatto acustico molto basso
- Voltaggio 220-240V~
- Frequenza: 50/60 Hz
- Compatto e PIÙ LEGGERO
- Rivestimento in gomma antiscivolo
- Motore potente con generatore di ioni.
- Compatibile con diffusori: 04346/50 - 01147 - 03036/50

## Robust Barber Line Föhn

### Asciugacapelli Robust di Barber Line

Barber Line

u.m.vta: 1  12 

REF. 06475



SCAN ME!



Hergestellt als ideale Ergänzung für den Friseur. Der neue Haartrockner ROBUST von Barber Line bietet einen hohen Luftstrom, erhöhte Leistung und verkürzte Trocknungszeit. Sie erlaubt es, jede Art von Frisur zu erstellen: geglättet, gewellt, Volumen, usw. Ihr Haar wird weich, glänzend und gesund aussehen.

- Leistung: 1900W - 2200W
- Spannung 220-240V~
- Frequenz: 50/60 Hz



*Progettato come accessorio ideale per il parrucchiere. Il nuovo asciugacapelli ROBUST di Barber Line offre un flusso d'aria elevato, prestazioni migliorate e tempi di asciugatura ridotti. Ti consente di creare qualsiasi tipo di acconciatura: liscia, ondulata, voluminosa, ecc. I capelli appariranno lisci, lucenti e sani.*

- Potenza: 1900W - 2200W
- Voltaggio 220-240V~
- Frequenza: 50/60 Hz



## Barber Line schwarzes Wachs Fixiergerät 125 ml Scaldacera nero Barber Line 125 ml

Barber Line

u.m.vta: 1  12 

REF.04505





- Kompakte Wachsschmelze
- Antihaft-Oberfläche für einfache Reinigung
- Variable Temperatureinstellungen
- Schnelles Aufheizen
- Schutzdeckel
- Fassungsvermögen: 125 ml
- Spannung: 220-240V~
- Leistung: 40 W
- Frequenz: 50 Hz
- Maximale Temperatur 90°C

- *Scaldacera compatto*
- *Superficie antiaderente per una facile pulizia*
- *Regolazione della temperatura*
- *Riscaldamento rapido*
- *Coperchio di protezione*
- *Capacità: 125 ml*
- *Voltaggio: 220-240V~*
- *Potenza: 40 W.*
- *Frequenza: 50 Hz*
- *Temperatura massima 90°C*



## Kleines Gätteeisen Barber Line für Bart und Pony Mini piastra Barber Line per barba e frangia

u.m.vta: 1  20 

REF. 06569/50



Mit den neuen Mini-Friseur-Haarglätteisen der letzten Generation können Sie jede Art von welliger oder glatter Frisur usw. erstellen. Professionelle Nutzung:

- Keramikplatten mit Turmalin, die das Haar pflegen und ihm Glanz und Geschmeidigkeit verleihen
- Spannung 100-240V~
- Frequenz: 50/60 Hz
- Leistung 22 W
- 2 m langes Kabel mit Gummi
- Aufheizen der Platten in nur 30 Sekunden, mit PTC-Widerstand
- Maximale Temperatur 200°C
- PTC-Widerstand verhindert Überhitzung
- Geeignet für alle natürlichen Haartypen
- NICHT FÜR KUNSTHAAR VERWENDEN
- NICHT FÜR NASSES HAAR GEEIGNET

Le nuove mini piastre Barber Line di ultima generazione consentono di creare qualsiasi tipo di acconciatura ondulata, liscia, ecc. Uso professionale.

- *Piastre in ceramica con tormalina donando lucentezza e morbidezza*
- *Voltaggio 100-240V~*
- *Frequenza: 50/60 Hz*
- *Potenza 22 W.*
- *Cavo in gomma lungo 2 m*
- *Riscaldamento della piastra in soli 30 secondi, con resistenza PTC*
- *Temperatura massima 200°C*
- *Resistenza PTC che impedisce il surriscaldamento*
- *Adatta a qualsiasi tipo di capello naturale*
- *NON USARE SU CAPELLI SINTETICI*
- *NON ADATTA A CAPELLI BAGNATI*

## Haarabsauger Aspiratore per capelli

u.m.vta: 1  1 

REF. 06612

P.M.P.R. 187,72€

SCAN  
ME!Behälter  
DepositoTaste "Manuell"  
Pulsante  
manualeSchmutzöffnung  
Entrata dei  
capelliSensoren  
SensoriAUTO-AUS  
MANUELL  
Einstellrad  
AUTO - OFF  
MANUALE  
Manopola di  
controlloLeuchtanzeige  
Indicatore di  
stato  
della luceFilter  
Filtro

Der Absauger HAIR VACUUM mit moderner Technologie erleichtert die Arbeit für den Fachmann. Er verfügt über zwei Arbeitseinstellungen:

- 1) Handbetrieb: Für eine Absaugdauer von 5 sek. Bei Bedarf kann man es mit Knopfdruck mehrmals aktivieren.
- 2) Autobetrieb: Mit Hilfe der leistungsfähigen Sensoren können die Resthaare dauernd abgesaugt werden, das erleichtert dem Fachmann die Arbeit. Das Gerät schaltet aus, wenn keine Reste mehr vorhanden sind.

- Nennleistung: 1400 W
- Modell: VA001A-BK
- Nennspannung: 220-240V~
- Frequenz: 50/60Hz
- Größe: (Länge x Breite x Höhe): 33 cm Länge x 21 Breite x 56,4 cm Höhe
- Nettogewicht: etwa 5,1Kg
- Betriebsgeräusch:  $\geq 83$ db 1,5m
- Automatischer Arbeitsmodus: Einführung von Infrarotstrahlung
- Sog (Zugfestigkeit):  $\geq 2,8$  Kg
- Fassungsvermögen des Behälters: 2,7L MAX
- Netzkabel Expositionsgröße: 2m

Aspiratore per capelli di ultima tecnologia. In modalità manuale, spazza i capelli verso la bocchetta di aspirazione alla base dell'apparecchio. Premere il pulsante di attivazione manuale e lasciare che HAIR VACUUM aspiri i capelli attraverso la bocchetta di aspirazione e li conservi nel deposito.

1. La modalità MANUALE durerà 5 secondi. A seconda della quantità di capelli, potrebbe essere necessario premere il pulsante di attivazione manuale più di una volta.
2. Quando la manopola di controllo viene ruotata sulla posizione AUTO, aspira i detriti attraverso la bocchetta di aspirazione alla base dell'apparecchio e i sensori rilevano i detriti e avviano automaticamente un ciclo di aspirazione che terminerà una volta che i sensori non rileveranno alcun capello.

- Potenza nominale: 1400 W.
- Modello: VA001A-BK
- Voltaggio nominale: 220-240V~
- Frequenza: 50/60Hz
- Dimensioni: (lunghezza x larghezza x altezza): 33 cm di lunghezza x 21 di larghezza x 56,4 cm di altezza
- Peso netto: circa 5,1kg
- Rumore di funzionamento:  $\geq 83$ db 1,5 m
- Modalità di lavoro automatica: introduzione di radiazione infrarossa
- Aspirazione (forza di trazione):  $\geq 2,8$  Kg
- Capacità del serbatoio dell'immondizia: 2,7 L MAX
- Dimensioni del cavo di alimentazione: 2m



### Sterilisator Eurostil UV-Aluminium Sterilizzatore Eurostil UV in alluminio

u.m.vta: 1  1

REF. 03317

- Leistung: 8W
- Geeignet für die Sterilisation von kleinen Utensilien aus Kunststoff oder Metall unter Verwendung einer keimtötenden UVC-Lampe
- Nicht für andere, nicht angegebene Objekte verwenden
- Die Glühbirne hält etwa 1300/1500 Stunden (= 1 Jahr Betriebsdauer)
- Potenza: 8W
- *Indicato per la sterilizzazione di piccoli utensili in plastica o metallo mediante una lampadina UVC germicida.*
- *Non utilizzare con altri oggetti non indicati.*
- *La lampadina dura circa 1300/1500 ore (= 1 anno di funzionamento).*



### Sanity Security Heissluft-Sterilisator Sterilizzatore a calore secco Sanity Security

u.m.vta: 1  1



REF. 03011

- Temperatur von 20°C bis 200°C
- Leistung 400W
- Innenmaße: 25 cm x 14,5 cm x 7 cm

- *Temperatura da 20°C a 200°C*
- *Potenza 400W.*
- *Misure interne: 25 cm x 14,5 cm x 7 cm*



## EUROSTIL-Quarz-Sterilisator Sterilizzatore al quarzo EUROSTIL

u.m.vta: 1  6 

REF. 07013

- Leistung: 75W
- Spannung: 220-240 V~
- Frequenz: 50/60Hz



- Potenza: 75W
- Voltaggio: 220 - 240 V~
- Frequenza: 50/60 Hz

- Quarz
- Ideal für Metallutensilien wie, Scheren
- Inklusive Tasche mit Quarzperlen

- Quarzo
- Ideale per utensili in metallo come forbici, etc.
- Include borsa con perle di quarzo



## Dose mit Quarzkugeln 500 g Contentore di sfere di quarzo 500 g

u.m.vta: 1  12 

REF. 06619

Zur Sterilisation von Metallwerkzeugen für  
Friseur- und Kosmetikbedarf.

Per sterilizzare strumenti in metallo sia per  
parrucchieri che per estetisti.



## Keimtötender Sterilisator GX4 Sterilizzatore germicida GX4



u.m.vta: 1 20



REF. 03009/59

- Leistung: 15W
- Temperatur von 20°C bis 200°C
- Ultraflach. Hochwertiges keimtötendes Licht

- Potenza: 15W.
- Temperatura da 20°C a 200°C
- Ultra piatto. Luce germicida di alta qualità



### Ersatzteile · Ricambi

u.m.vta: 1 1

REF. RE00891/01

Ersatz-UV-Lampe  
Ricambio lampadina UV



## Eurostil UV- Sterilisator Kunststoff Sterilizzatore Eurostil UV in plastica

u.m.vta: 1 1

REF. 06618

- Leistung: 8W
- Ultraviolett-Sterilisator für alle Arten von Werkzeugen sowohl für die Friseur- als auch für die Schönheitspflege

- Potenza: 8W
- Sterilizzatore ultravioletto per tutti i tipi di strumenti, sia per parrucchieri che per estetisti



u.m.vta: 1 1

REF. RE06618/01

Ersatz-UV-Lampe 8W  
Ricambio lampadina UV 8W

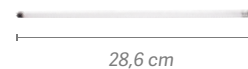



02

## Rasiermesser und rasierklingen Rasoie lame

Rasiermesser, Messer, Rasierstifte,  
Schäume und Gele...

Rasoie, lamette, pen razor, schiume e gel ...

**Rasiermesser REFINED**  
**Rasoio a mano libera REFINED**

**RAGNAR**  
 BARBER LINE

u.m.vta: 1  12

● Schwarz · Nero

REF.07163



● Silber · Argento

REF.07161



● Altes Kupfer · Vecchio rame

REF.07162



- Messung: 14,5 cm
- Für einschneidige Klinge Wellblech
- STAHL J2 HOCHWERTIG (420C)
- Logo mit Laser graviert

- Misura: 14,5 cm
- Per lametta a taglio unico ondulata
- ACCIAIO J2 DI ALTA QUALITÀ (420C)



## Rasiermesser **PRECISE**

### Rasoio a mano libera **PRECISE**

**RAGNAR**  
BARBER LINE

u.m.vta: 1  100

REF.07124

- Ideal zum Trimmen und zum Rasieren
- Halbklinge gerillt
- Griff schwarz
- Maße: 15 x 2,6 x 1,1 cm
- Mit Platinbad für ein besseres Rasieren und Trimmen

- *Ideale per ritocchi e rasatura*
- *Mezza lametta ondulata*
- *Manico nero*
- *Misure: 15 x 2,6 x 1,1 cm*
- *Placcato platino per rasatura e ritocco migliori*



## RAGNAR-Messer mit schwarzem Metallgriff

### Rasoio RAGNAR con manico in metallo nero

u.m.vta: 1  25

REF.06986

- Sehr leichtes Rasiermesser mit schwarzem Griff zum Rasieren und Trimmen von Bärten und Haaren.
- Einschneidige Klinge
- *Rasoio leggerissimo per rasatura e ritocchi a barba e capelli con manico in metallo nero*
- *Mezza lama.*



## Klassischer Rasierhobel für Rasierklingen

### Rasoio classico

Barber Line

u.m.vta: 1  12

REF.04929

u.m.vta: 1  7

REF.04550

u.m.vta: 1  6

REF.04933

Klassischer, zweischneidiger Rasierer für Rasierklingen, ein unverzichtbares Werkzeug für den Barbier. Das Rasiermesser aus rostfreiem Stahl hat einen gerillten Griff für einen besseren Halt. Geeignet für Anfänger. Geeignet für alle auf dem Markt erhältlichen zweischneidigen Klingen.

- Zweischneidige Klinge

*Rasoio classico, con lama intera e a doppio taglio, uno strumento essenziale per il barbiere. Il rasoio ha un manico in acciaio inossidabile strutturato per offrire una presa migliore. Adatto ai principianti. Adatto a qualsiasi lametta a doppio taglio disponibile sul mercato.*

- Lama intera a doppio taglio



## Klassischer Rasierhobel für Rasierklingen

### Rasoio classico

u.m.vta: 1  12

REF.04931

- Klassischer Rasier mit zweischneidiger Klinge und Kunststoffgriff für einen besseren Halt. Inklusive einer eleganten Box.
- Zweischneidige Klinge
- Rasoio classico con lama a doppio taglio e manico in plastica per offrire una presa migliore. Include una elegante custodia.
- Lama intera a doppio taglio



## Rasiermesser mit Holzgriff

### Rasoio a mano libera con manico in legno

*Barber Line*

u.m.vta: 1  12

**REF.04930**

- Einschneidige Klinge. Wechselbar
- Lama a taglio unico. Intercambiabile



u.m.vta: 1  12

**REF. 04983**

Rasiermesser aus rostfreiem Stahl AISI 430, Farbe schwarz, hergestellt in Japan. Schwarz mit einem orangefarbenen Griff aus amerikanischem Holz. Inklusive einer eleganten Kartonschachtel.

- Einschneidige Klinger

*Rasoio in acciaio inossidabile 430, nero, prodotto in Giappone. Rivestimento nero e manico in legno americano di colore arancione. Include una elegante custodia di cartone.*

- Lama a taglio unico



## Rasiermesser mit Kunststoffgriff

### Rasoio a mano libera con manico in plastica

u.m.vta: 1  10

**REF.04898**

- Zweischneidige Klinge
- Lama intera a doppio taglio



Rasieren kann zu einem Akt des Luxus und einer gewissen Genuss werden. Mit der Barber Line von Eurostil, die auf mehr als 75 Jahre Erfahrung in der Friseurwelt zurückblickt, haben wir diese Produktreihe für den modernen Mann mit der Eleganz der Vergangenheit geschaffen.

*La rasatura può diventare un lusso da veri intenditori. Con la linea Barber di Eurostil, grazie a più di 75 anni di esperienza nel mondo nel mondo barber, abbiamo creato questa linea di prodotti per l'uomo moderno con l'eleganza di un tempo.*



### Rasiermesser mit Kunststoffgriff

#### Rasoio a mano libera con manico in plastica

u.m.vta: 1  10

REF.06057

- Einschneidige Klinge. Wechselbar
- Lama a taglio unico. Intercambiabile



Barber Line

### Rasiermesser mit Metallgriff

#### Rasoio a mano libera con manico in metallo

u.m.vta: 1  10



REF.06058

- Einschneidige Klinge. Wechselbar
- Lama a taglio unico. Intercambiabile



### BARBER-LINIEN Rasiermesser

#### Rasoi BARBER LINE

u.m.vta: 1  12 

REF.06647

- Ideal zum Trimmen
- Zweiseidige Klinge
- Ideale per ritocchi
- Lama intera a doppio taglio



### Kleines schwarzes Rasiermesser

#### Rasoio nero piccolo

u.m.vta: 1  12

REF.06435

- Sehr kurz, ideal zum Nachbessern und für schwer zugängliche Bereiche
- Einschneidige Klinge
- Molto corto, ideale per ritocchi e zone difficili da raggiungere
- Lama a taglio unico.



**Trimmklinge****Rasoio per ritocchi**u.m.vta: 1  12**REF.06421**

- Sehr kurz, ideal zum Nachbessern und für schwer zugängliche Bereiche
- Einschneidige Klinge

- *Molto corto, ideale per ritocchi e zone difficili da raggiungere*
- *Lama a taglio unico.*

**Messer mit Schutz und Gummi BARBER LINE**  
**Rasoio BARBER LINE con protezione e gomma**
*Barber Line*u.m.vta: 1  12**REF.06417**

- Mit Gummi
- Drehring am Griff für mehr Komfort

- *Con gomma*
- *Anello girevole sul manico per un comfort maggiore*

**REF.06419****REF.06420**

- Mit Gummi
- *Senza gomma*

**Ersatzteile**  
**Ricambi**
**REF. 07123****REF. 04388****REF. 04389**



## RATSCHLAG CONSIGLIO

Wenn Sie mit dem Rasieren fertig sind, waschen Sie den Rasierer unter fließendem Wasser, um Haare und Schaum von der Klinge zu entfernen. Trocknen Sie es, indem Sie es mit einem Tuch oder Handtuch abreiben. Es hat viele Vorteile sich mit einem Rasiermesser zu rasieren, die geringen Kosten, da keine Ersatzklingen gekauft werden müssen, die bessere Kontrolle auf der Haut durch eine größere Klinge. Die richtige Rasur bietet oft eine glattere, gründlichere Rasur und ist ein Ritual, auf das sich viele jeden Morgen freuen.

*Quando hai finito di raderti, lava il rasoio sotto l'acqua corrente per rimuovere peli e schiuma dalla lama. Asciugalo strofinandolo con un panno o un asciugamano. Ci sono molti vantaggi nel radersi con un rasoio, i bassi costi di non acquistare lametta usa e getta, il miglior controllo nel manovrare sulla pelle un bordo di taglio più grande di quello una lametta. Radarsi correttamente fornisce spesso una rasatura più liscia e più profonda e un rituale che molti aspettano con ansia ogni mattina.*

### Captain Cook Rasiermesser Rasoio a mano libera Captain Cook

u.m.vta: 1 10

**REF.04894**

Präzisions-Rasiermesser mit Captain-Cook-Holzgriff und zweischneidiger Klinge, ideal zum Rasieren. Enthält eine Schachtel zur ordnungsgemäßen Aufbewahrung

*Rasoio di precisione Captain Cook con manico in legno e lametta a doppio taglio, ideale per la rasatura. Include una custodia per una corretta conservazione*



u.m.vta: 1 12

**REF.04932**

Messer mit Universal-Wechselklinge. Ergonomisch dank des Designs des Griffs, der die Rasur sehr komfortabel macht. Enthält eine elegante Etui. Einschneidige Klinge

*Rasoio a mano libera con lametta intercambiabile universale. Ergonomic grazie al design dell'impugnatura che lo rende molto comodo per la rasatura. Include una elegante custodia. Mezza lametta*



u.m.vta: 1 12

**REF.04984**

Klassischer Rasierer mit Universal-Wechselklinge. Mit Holzgriff, einschließlich einer angenehmen Ledertasche. Einschneidige Klinge

*Rasoio a mano libera con lametta intercambiabile universale. Con manico in legno, include una comoda custodia in similpelle. Mezza lametta.*



u.m.vta: 1 12

**REF.04985**

Avantgardistisch aussehendes Messer, schwarz mit Universal-Wechselklinge. Es hat einen breiten schwarzen Holzgriff und beinhaltet ein angenehmes Kunstlederetui. Einschneidige Klinge

*Rasoio dal design all'avanguardia, con lametta intercambiabile universale. Con manico ampio in legno nero, include una comoda custodia in similpelle. Mezza lametta.*





### Kleines schwarzes Messer

#### Rasoio nero piccolo

u.m.vta: 1 12

REF.06434

- Sehr kurz, ideal zum Nachbessern und für schwer zugängliche Bereiche
- Einschneidige Klinge
- *Molto corto, ideale per ritocchi e zone difficili da raggiungere*
- *Lama a taglio unico.*



### Trimmklinge

#### Rasoio per ritocchi

u.m.vta: 1 12

REF.06422

- Sehr kurz, ideal zum Nachbessern und für schwer zugängliche Bereiche
- Einschneidige Klinge
- *Molto corto, ideale per ritocchi e zone difficili da raggiungere*
- *Lama a taglio unico*



### Schwarzes Messer mit Schutz und Gummi

#### Rasoio nero con protezione e gomma

u.m.vta: 1 12

REF.06418

- Mit Gummi
- Drehring am Griff für mehr Komfort
- *Con gomma*
- *Anello girevole sul manico per un comfort maggiore*



u.m.vta: 1 12

REF.06423

- Ohne Gummi
- *Senza gomma*



Ersatzteile  
Ricambi

REF. 07123



REF. 04388



REF. 04389



### Auswechselbare Klinge

#### Rasoio a lametta intercambiabile

u.m.vta: 1  12

REF.02124

- Rostfreier Stahl
- Einschneidige Klinge
- Acciaio inossidabile
- Lama a taglio unico.



### Rasiermesser

#### Rasoio per barba

u.m.vta: 1  12

REF.00698

- Einschneidige Klinge. Wechselbar
- Rostfreier Stahl
- Lama a taglio unico. Intercambiabile
- Acciaio inossidabile



### Haarschneidmesser

#### Rasoio per capelli

u.m.vta: 1  12

REF.00730

- Einschneidige Klinge. Wechselbar .
- Mit Kamm
- Lama a taglio unico. Intercambiabile
- Con Rialzi



### Metall-Rasiermesser

#### Rasoio in metallo per barba

u.m.vta: 1  12

REF.04543

- Einschneidige Klinge. Wechselbar
- Lama a taglio unico. Intercambiabile

u.m.vta: 1  12

REF.04544

- Einschneidige Klinge. Wechselbar
- Schwarzer Gummigriff
- Lama a taglio unico. Intercambiabile
- Manico in gomma nera



**Spender mit 20 Klingen**  
**Dispenser 20 lame**

**Professional PB-20**

u.m.vta: 1  10

REF.04391



**FEATHER ARTIST ACS-RB-Rasiermesser**  
**Rasoio FEATHER ARTIST ACS-RB**



u.m.vta: 1  6

**Artist ACS-RB**  
**REF.04390**



**FEATHER ARTIST CLUB SS SCOTCH WOOD -Rasiermesser**  
**Rasoio FEATHER ARTIST CLUB SS SCOTCH WOOD**

u.m.vta: 1  6

**Artist ACS-RSW**  
**REF.04902**



**FEATHER DOUBLE EDGE POPULAR**  
**Rasoio FEATHER DOUBLE EDGE POPULAR**

u.m.vta: 1  12

REF.04392



u.m.vta: 20  20



REF.04393

**Schachtel mit 10 Klingen**  
**DOUBLE EDGE**  
**Confezione da 10 lame**  
**DOUBLE EDGE**





**Box mit 10 schachteln mit 100 rostfreien halbklingen für den professionellen gebrauch**  
**Confezione da 10 scatoline da 100 mezza lame inox per uso professionale**

u.m.vta: 1  10 



REF.07164

- Einschneidige Klinge
- Premium rostfreies, glattes und präzises Schneiden
- 10 Kartons x 100 rasierklingen

- Mezza lama
- Taglio premium inossidabile, liscio e preciso
- 10 scatole x 100 lame



**Behälter für gebrauchte rasierklingen**  
**Contentore lame usate**

u.m.vta: 1  6 

REF.07258

Dieser Behälter von reduzierter Größe ist ideal für die Entsorgung von gebrauchten Rasierklingen durch Friseure.

- Farbe: schwarz
- Maße: Unterlage 7,5 x 7,5 cm, oberer Teil 9 x 9 cm / Höhe: 15 cm
- Fassungsvermögen: etwa 1 l

*Di piccole dimensioni, questo contenitore è ideale per smaltire le lame da barba usate da parrucchieri e barbieri.*

- Colore nero
- Dimensioni: base 7,5 x 7,5 cm parte superiore 9 x 9 cm / altezza: 15 cm
- Capacità: 1l circa



**Spender mit 20 Schachteln ELIOS****Dispenser da 20 scatole ELIOS**u.m.vta: 1  50 **REF. 00994**

Rasierklingen-Referenz für Fachleute. Bessere Qualität der Klinge, bessere Schärfe und geschmeidige Anwendung

- Rasierklingen aus Edelstahl
- Traditioneller schwedischer Qualitätsstahl
- Mit Platin behandelt für eine perfekte und sichere Rasur



Una lametta da rasoio di riferimento per i professionisti. Migliore qualità della lama, migliore affilatura e comfort d'uso

- lame da rasoio inossidabili
- Acciaio svedese tradizionale di alta qualità
- Trattate al platino per una rasatura perfetta e sicura



- 10 ELIOS-Rasierklingen
- 10 lame con incastro ELIOS

u.m.vta: 1  240 **REF.01351**



- 5 BIC-Rasierklingen
- 5 lame con incastro BIC

u.m.vta: 1  50 **REF.00995**



- 5 BOLZANO Rasierklingen
- 5 lame con incastro BOLZANO

u.m.vta: 1  50 **REF. 06161**

- 5 DERBY PREMIUM Rasierklingen
- 5 lame con incastro DERBY PREMIUM

u.m.vta: 1  50 **REF.02956**

- 5 Rasierklingen
- 5 lame con incastro DERBY

u.m.vta: 1  80 **REF.02308**

- 10 Supermax-Rasierklingen
- 10 lame Supermax





### ASTRA Spender 20 Schachteln 5 Blatt Dispenser ASTRA 20 scatole 5 fogli

u.m.vta: 1  100 

REF.07100



Rasierklingen von hoher Schärfe und großer Glätte. Sie sind aus rostfreiem Stahl gefertigt und platinbeschichtet.  
Die Schachtel enthält zwanzig Kartonspender mit je fünf Klingen, die in Wachspapier eingewickelt sind.

*Lame da rasoio ad alta affilatura e di garn comfort. Realizzate in acciaio inossidabile e rivestimento in platino.*

*La confezione contiene venti dispenser di cartone con cinque lame avvolte in carta oleata ciascuno.*



### Box 100 Einweg Rasierklingen Confezione da 100 lame usa e getta

u.m.vta: 1  50 

**Derby Premium**  
REF. 06160



**Derby Professional**  
REF. 02955



### Schachtel mit Klingen Confezione di lame



u.m.vta: 1  50

REF.09101

- 10 Ersatzklingen 06192
- 10 lame di ricambio per rasoio 06192



## Spenderbox mit 100 versiegelten RAGNAR einweg-rasiermessern Dispenser da 100 lamette monouso RAGNAR sigillate



u.m.vta: 1  12 

REF. 07439

Aus erstklassigem Plastik gefertigt. Die Schneide aus gehärtetem rostfreiem schwedischem Stahl und die scharfe Klinge gewährleisten professionelle Qualität bei jedem Schnitt. Leicht, bequem und genau bei Rasur oder Haarschnitt. RAGNAR Einweg-Rasiermesser gewährleisten maximale Hygiene für Ihre Kunden, da sie über ein leicht zu öffnendes Sicherheitssiegel verfügen.



*Realizzate in materiale plastico di prima qualità. La lama in acciaio inossidabile temperato svedese e la perfetta affilatura garantiscono una qualità professionale a ogni rasatura.*

*Leggere, comode e precise durante la rasatura o il taglio dei capelli. Il rasoio monouso RAGNAR è garanzia di massima igiene per il tuo cliente, poiché ha un sigillo di sicurezza di facile apertura.*

u.m.vta: 1  7 

REF. 02479

- Schachtel mit 100 Einweg Rasiermessern von Pollié
- Confezione da 100 lame usa e getta Pollié



u.m.vta: 1  12 

REF. 01951

- Schachtel mit 100 Einweg Rasiermessern
- Confezione da 100 lame usa e getta



## Schachtel Einweg-Rasiermesser Eurostil Confezione di lame usa e getta Eurostil

u.m.vta: 1  15 

REF. 03882

- 100 Rasiermesser (3 Farben)
- Ergonomisches Design
- 100 lame assortite (3 colori)
- Design ergonomico



## Spender für Rasiermesser 03882 Dispenser per lame 03882

u.m.vta: 1  6

REF.04523

- Leer
- Vuoto



**Pen razor****Pen Razor**u.m.vta: 1  20

REF.06154

- Pen razor + 20 Klingen
- Rasoio a penna + 20 lamette



Ideal für Grafiken im Haar  
Ideale per disegnare sui capelli

u.m.vta: 1  200

REF.06155

- Spender für 20 Klingen Pen razor
- Dispenser 20 lame per rasoio a penna

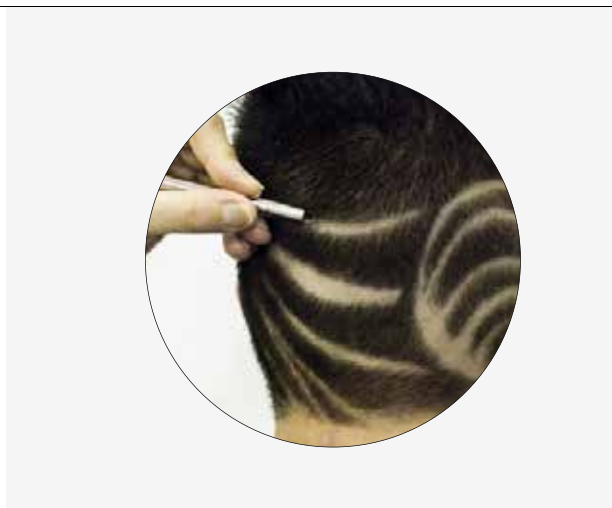

Ideal für Grafiken im Haar  
Ideale per disegnare sui capelli

**Rasierschaum BIC Sensitive**  
**Schiuma da barba BIC Sensitive**

u.m.vta: 6  6

250 ml

REF.03286

Speziell für empfindliche Haut erstellter Rasierschaum Seine Formel mit Aloe Vera ist für ihre beruhigende Wirkung bekannt und hilft, die durch die Rasur verursachten Reizungen zu lindern.

Schiuma appositamente formulata per pelli sensibili. La sua formula con aloe vera è nota per i suoi effetti calmanti e aiuta ad alleviare l'irritazione causata dalla rasatura.





03

## Scheren Forbici

*Professionelle Schneide- und  
Modellerscheren*

*Forbici per tagliare e sfoltire*

## BARBER LINE-Scheren · Forbici BARBER LINE

Industrias Oriol präsentiert seine Scheren Produktreihe von hoher Qualität. Entworfen, um die Arbeit des Profis dank seiner Präzisionsschneide zu vereinfachen. Widerstandsfähig gegen hohe Abnutzung und mit einer handgefertigten Oberfläche für maximale Qualität und Präzision.

**MATERIALEIGENSCHAFTEN**

•VG-10 Edelstahl der höchsten Qualität, dieser Stahl ist ein ausgezeichneter japanischer Stahl mit hohem Kohlenstoffgehalt. Dieser Stahl bietet uns eine größere Korrosionsbeständigkeit und eine größere Fähigkeit, die Schneidkante zu halten. Seine Zusammensetzung ist wie folgt: Kohlenstoff: 1,05% - 1,5%, Mangan: 0,5%, Chrom: 14,5% - 15,5%, Vanadium: 0,1 - 0,3%, Molybdän: 0,9% - 1,2% und Kobalt: 1,5%. Aus dieser Mischung entsteht der Stahl VG-10, dessen Eigenschaften ungewöhnlich sind, was zu einer hohen Verschleißfestigkeit und damit zu einer großen Haltbarkeit führt. Sie hat eine Härte von bis zu 62 HRC.

•Martensitischer rostfreier Stahl 440C: C: 1,05% Mn: 0,45% Si: 0,40% Cr: 17,50% Mo: 0,70% S: <0,030%. Diese Stahlsorte hat einen hohen Chrom- und Kohlenstoffgehalt, die für eine hohe Verschleiß- und Oxidationsbeständigkeit in feuchten Umgebungen ausgelegt ist. Es erreicht eine Härte von nahezu 60 HRC und bietet eine gute Stabilität der Schneidkante. Härte: 59-61 HRC.

**GRÖSSE DER SCHEREN**

Die Größe der Schere wird in der Regel in Zoll gemessen. Die kurzen sind 4,5 Zoll lang, und die längeren gehen bis zu etwa 8 Zoll. Scheren werden von der Spitze bis zum längsten Griff gemessen, wobei die abnehmbare oder permanente Fingerauflage nicht berücksichtigt wird.

Die Größe wird je nach Schnitttechnik gewählt. Kürzere Scheren eignen sich besser für Detailarbeiten, längere Scheren eignen sich besser für kraftvolle Arbeiten. Die Scheren in den Größen 5,0" (13cm), 5,5" (14cm), 6,0" (15cm) und 6,5" (16cm) werden am häufigsten von Fachleuten verwendet.

**ARTEN VON SCHEREN UND GRIFFEN**

Die Typen, die wir finden können, sind:

- Rasierklingschere: Sie hat zwei gerade Blätter, ideal für Fransenschnitt.
- Schere zum Ausdünnen oder Modellieren: Sie besteht aus einer gezackten Klinge und einer scharfen Klinge, ideal zum proportionalen Ausdünnen der Haare.
- Mikroverzahnte Schneideschere: Diese Schere hat eine mikroverzahnte Klinge auf einer oder beiden Klingen, ideal, um ein Verrutschen der Haare beim Schneiden zu verhindern.
- Ausdünnungsschere: Die beiden Blätter sind gezahnt oder gekämmt, ideal zum Ausdünnen von Haar und zur Volumenreduzierung oder Markierung von Schichten ohne Längenverlust.



4"5"

REF.06281

Gegenüberliegender Griff,  
einfach oder symmetrisch

*Impugnatura opposta, basica  
o simmetrica*



5"5"

REF. 04629

Halbversetzter oder  
halbkompensierter Griff

*Impugnatura semi offset o semi  
compensata*



5"5"

REF. 04630

Versetzter oder  
kompensierter Griff

*Impugnatura offset o  
compensata*

Industrias Oriol S.L. presenta la sua linea di forbici di alta qualità. Progettate per favorire il lavoro del professionista grazie alla sua affilatura di precisione. Resistenti all'usura e con una finitura artigianale per ottenere la massima qualità e precisione.

**PROPRIETÀ DEI MATERIALI**

• Questo acciaio inossidabile VG-10 di altissima qualità è un eccellente acciaio giapponese ad alto tenore di carbonio. Offre una maggiore resistenza alla corrosione e una maggiore capacità di conservare l'affilatura. La sua composizione: carbonio: 1,05% - 1,5%, manganese: 0,5%, cromo: 14,5% - 15,5%, vanadio: 0,1 - 0,3%, molibdeno: 0,9% - 1,2% e cobalto: 1,5%. Questa lega dà origine all'acciaio VG-10 e le sue proprietà sono più uniche che rare, il che porta ad una elevata resistenza all'usura e quindi a una lunga durata. Ha una durezza fino a 62 HRC.

• Acciaio inossidabile 440C: C: 1,05% Mn: 0,45% Si: 0,40% Cr: 17,50% Mo: 0,70% S: <0,030%. Questo tipo di acciaio ha un alto contenuto di cromo e carbonio ed è progettato per offrire un'elevata resistenza all'usura e all'ossidazione in ambienti umidi. Raggiunge durezza vicine a 60 HRC e offre una buona conservazione dell'affilatura. Durezza: 59-61 HRC.

**DIMENSIONI DELLE FORBICI**

Le dimensioni delle forbici vengono generalmente misurate in pollici. Quelle corte sono di 4,5 pollici e le più lunghe arrivano fino a circa 8 pollici. Le forbici vengono misurate dalla punta al manico più lungo, escluso il poggia dito fisso o staccabile.

Le dimensioni vengono selezionate in base alla tecnica di taglio. Forbici più corte sono più adatte per lavori dettagliati, forbici lunghe sono più adatte per lavori di grande volume. Le forbici da 13 cm, 14 cm, 15 cm e 16 cm sono le più utilizzate dai professionisti.

**TIPI DI FORBICI E MANICI**

Le tipologie che possiamo trovare sono:

- Forbici da taglio affilatura a rasoio: Hanno entrambe le lame dritte, ideali per scalare.
- Forbici per sfoltire: sono costituite da una lama seghettata e una lama affilata, ideali per sfoltire proporzionalmente i capelli.
- Forbici da taglio micro-seghettate: sono quelle che hanno una micro-dentatura su una o entrambe le lame, ideali affinché capelli non scivolino durante il taglio.



### Bartschere ROOSTER

#### Forbici da barbiere ROOSTER

Werkstoff: japanischer 440C-Stahl  
Härte: 59-61 HRC

Materiale: acciaio giapponese 440C  
Durezza: 59-61 HRC

u.m.vta: 1  10

REF.06958

Schnitt  
Tagliare

6,5"



REF.06959

Schnitt  
Tagliare

7"



REF.06960

Modellier  
Sfoltire

6,5"



REF.06958/71

Schnitt  
Tagliare

6,5"



REF.06959/71

Schnitt  
Tagliare

7"



REF.06960/71

Modellier  
Sfoltire

6,5"



### Bartschere GLORIOUS

#### Forbici da barbiere GLORIOUS

Werkstoff: japanischer 440C-Stahl  
Härte: 59-61 HRC

Materiale: acciaio giapponese 440C  
Durezza: 59-61 HRC

u.m.vta: 1  10

REF.06967

Schnitt  
Tagliare

6,5"



REF.06968

Schnitt  
Tagliare

7"



REF.06969

Modellier  
Sfoltire

6,5"





**Bartschere LEFT DOMINANT (LINKSHÄNDER)**  
**Forbici da barbiere LEFT DOMINANT (MANCINI)**

Werkstoff: japanischer 440C-Stahl  
 Härte: 59-61 HRC

Materiale: acciaio giapponese 440C  
 Durezza: 59-61 HRC

u.m.vta: 1  10

REF.06979

Schnitt  
 Tagliare

6,5"

REF.06980

Schnitt  
 Tagliare

7"

REF.06981

Modellier  
 Sfaltire

6,5"

REF.06979/71

Schnitt  
 Tagliare

6,5"

REF.06980/71

Schnitt  
 Tagliare

7"

REF.06981/71

Modellier  
 Sfaltire

6,5"

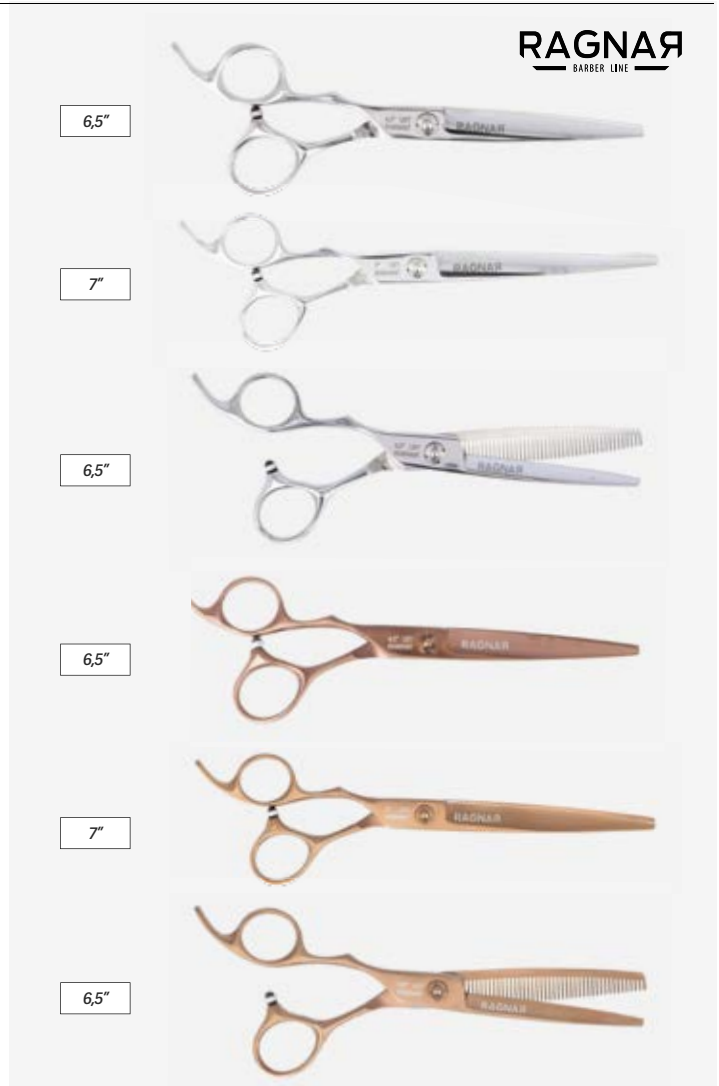



## Bartschere BLACK PEARL

### Forbici da barbiere BLACK PEARL

u.m.vta: 1  10

REF.06392

- Schnitt
- Tagliare



REF.06393

- Modellier
- 32 schräge Zähne
- Scolpire
- 32 denti obliqui



5,5"



6"

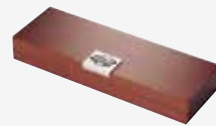

- Werkstoff: Japanischer 440C-Stahl
- Gehäuse: schwarzes Titan
- Schraube: kugelgelagerte Fingereinstellung
- Härte: 62 HRC
- Griff: Versatz

- Materiale: acciaio giapponese 440C
- Corpo: titanio nero
- Vite: regolazione del dito con cuscinetto a sfera
- Durezza: 62 HRC
- Impugnatura: offset

u.m.vta: 1  10

REF.04895

- Schnitt
- Tagliare



REF.04896

- Modellier
- 50 Zähne
- Sfaltire
- 50 denti

7"



7"



- Werkstoff: 440C-Stahl
- Härte: 60HRC
- Rand: konvex

- Materiale: acciaio 440C
- Durezza: 60HRC
- Bordo: convesso





## Bartschere BLACK PEARL

### Forbici da barbiere BLACK PEARL

u.m.vta: 1  10

REF.06394

- Modellier
- 32 schräge Zähne
- Sfaltire
- 32 denti obliqui



- Werkstoff: Japanischer 440C-Stahl
- Gehäuse: schwarzes Titan
- Schraube: kugelgelagerte Fingereinstellung
- Härte: 62 HRC
- Griff: Versatz

- Materiale: acciaio giapponese 440C
- Corpo: titanio nero
- Vite: regolazione del dito con cuscinetto a sfera
- Durezza: 62 HRC
- Impugnatura: offset

## Bartschere BLACK RIPPER

### Forbici da barbiere BLACK RIPPER

u.m.vta: 1  10

REF.06478

- Modellier
- Sfaltire

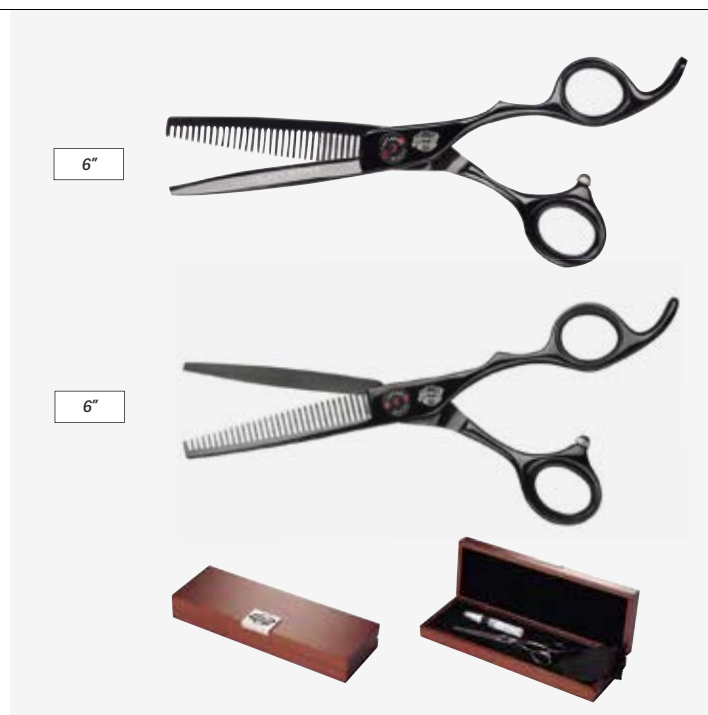

REF.06479

- Modellier
- Sfaltire

Japanischer Stahl 440C. Seine Klengen wurden mit einem überlegenen Schärfegrad hergestellt, so dass sie für alle Arten von Schnitten mit nassem oder trockenem Haar geeignet sind. Diese Scheren haben ein kühnes und modernes Design, entsprechen aber durchaus dem Stil der "alten Schule". 32 gerade Zähne.

Acciaio giapponese 440C Le sue lame sono state prodotte con un grado di affilatura più elevato che le rende ideali per tutti i tipi di taglio, con capelli bagnati o asciutti. Queste forbici hanno un design audace e moderno ma non stonano con lo stile "old school". 32 denti.



### Bartschere SILVER DIAMOND

#### Forbici da barbiere SILVER DIAMOND

u.m.vta: 1 10

REF.04897

Schnitt  
Tagliare

8"



- Werkstoff: Japanischer 440C-Stahl
- Körper: Titan
- Schraube: kugelgelagerte Fingereinstellung
- Härte: 62HRC
- Rand: konvex
- Griff: Versatz

- Materiale: acciaio giapponese 440C
- Corpo: titanio
- Vite: regolazione del dito con cuscinetto a sfera
- Durezza: 62HRC
- Bordo: convesso
- Impugnatura: offset

### Bartschere BLACK QUEEN

#### Forbici da barbiere BLACK QUEEN

u.m.vta: 1 10

REF.06961

- Drehbares Auge
- Impugnatura rotante

6,5"



Werkstoff: Japanischer 440C-Stahl  
SchnittHärte: 59-61 HRC

Materiale: Acciaio giapponese 440C  
Durezza: 59-61 HRC

### Bartschere LEGEND

#### Forbici da barbiere LEGEND

u.m.vta: 1 10

REF.06962

Schnitt  
Tagliare

6,5"



REF.06963

Modellier  
Sfoltire

6,5"



Werkstoff: japanischer 440C-Stahl  
Härte: 59-61 HRC

Materiale: acciaio giapponese 440C  
Durezza: 59-61 HRC

## Bartschere NEPTUNO

### Forbici da barbiere NEPTUNO

Barber Line

u.m.vta: 1  10 

REF. 04625

- Schnitt
- Tagliare

REF. 04626

- Modellier
- Sfaltire



- Stahl 440
- Messerschliff
- Manuelle Endbearbeitung
- Hohe Härte 59,61 HRC
- Einstellschrauben
- Etui

- Acciaio 440
- Affilatura a rasoio
- Finitura manuale
- Elevata durezza 59,61 HRC
- Viti di regolazione
- Custodia individuale

## Bartschere BARBER LINE

### Forbici da barbiere BARBER LINE

u.m.vta: 1  10

REF.04899

- Schnitt
- Tagliare

- Werkstoff: 440C-Stahl
- Härte: 60 HRC
- Rand: konvex



- Materiale: acciaio 440C
- Durezza: 60 HRC
- Bordo: convesso

u.m.vta: 1  12

REF.06281

- Schnitt
- Tagliare



- Ideal zum Nachbessern des Bartes
- Ideale per ritoccare la barba

## PIRATA Schere

### Forbici PIRATA

u.m.vta: 1  10 

REF. 04630

- Schnitt
- Tagliare



### WAVES-Friseurschere Stahl

#### Forbici da taglio in acciaio WAVES

u.m.vta: 1  12

REF.04316

- Schnitt
- Tagliare

6"



REF.04317

- Modellier
- Sfaltire

5,75"



### Professionelle Friseurschere ERGO

#### Forbici professionali ERGO

u.m.vta: 1  12

REF.04314

- Schnitt
- Tagliare

6"



REF.04315

- Modellier
- Sfaltire

6"



**Friseurschere mit Messerschliff in schwarz und goldenem Griff**  
**Forbici affilatura a rasoio, nere con manico dorato**

u.m.vta: 1  12

**REF.04499**

- Schnitt
- Tagliare

**REF.04500**

- Modellier
- Sfaltire



**Friseurschere mit Messerschliff in schwarz matt**  
**Forbici affilatura a rasoio, nero satinato**

u.m.vta: 1  12

**REF.04501**

- Schnitt
- Tagliare

**REF.04502**

- Modellier
- Sfaltire



## Azubi-Scheren Forbici RAGNAR

u.m.vta: 1  12

REF.04359

- Schnitt
- Tagliare

u.m.vta: 1  12

REF.04361

- ModellierAusdünnen
- Sfaltire



## ModellierAusdünnen Kit taglio studente

u.m.vta: 1  50

REF.04901

- 1 Friserschere
- 1 Modellerschere
- 1 Rasiermesser Metall

- 1 Forbice da taglio
- 1 Forbice per scolpire
- 1 Rasoio in metallo



## Spezielle professionelle Schere LINKSHÄNDER

### Forbici professionali speciali per MANCINI

u.m.vta: 1		30
------------	---	----

REF.02213

- Schnitt
- Tagliare



## LINKSHÄNDER Messerschliff Schere MATT

### Forbici a rasoio per MANCINI MATT

u.m.vta: 1		12
------------	---	----

REF.04503

- Schnitt
- Tagliare



REF.04504

- Modellier
- Sfaltire

04

## Bürsten und pinsel Spazzole e pennelli

*Bartbürsten und  
Rasierpinsel, Talkumpulver...*

*spazzole, pennelli e talco...*





**Bartbürste aus NYLON mit Talkumpuderreservoir**  
**Pennello da collo, setole in nylon con spargitalco**

u.m.vta: 6  36



REF.01463

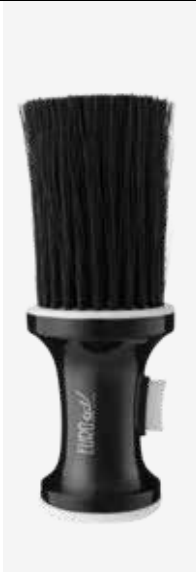

u.m.vta: 6  60

REF.01463/50



u.m.vta: 1  6 

REF. 00788





**Bartbürste nylon**  
**Pennello da collo nylon**

u.m.vta: 1  6 

REF. 03403





u.m.vta: 1  20 

REF. 01412





**Bartbürste holzgriff**  
**Pennello da collo manico in legno**

u.m.vta: 1  12 

REF. 00336



**Rasierpinsel****Pennelli da barba**u.m.vta: 1  7 

Ø 21

REF. 07810

Ø 21

Ø 24



- Naturborsten Schweine
- Pferd, braune Haare

- Stuzzicadenti naturali
- cavallo, capelli castani

REF. 04372

Ø 24



- Natürliche Ponyhaar-Borsten
- Setole di pelo naturale di pony

Ø 24

REF. 07811

**Vintage-Rasierpinsel****Pennelli da barba vintage**u.m.vta: 1  20

S

REF.00644

- Die Borsten der Bürste sind natürliches Schweinehaar (mit Chlor gekocht, um die Farbe aufzuhellen)
- Borsten etwa 5 cm lang
- Holz- und Metallgriff

- Le setole del pennello sono in pelo naturale di maiale (bollite con cloro per schiarire il colore)
- Setole da 5 cm circa di lunghezza
- Manico in legno e metallo

L

REF.00645



S





L

**Rasier Seifenschale****Portasapone da barba**u.m.vta: 1  4



REF.04255



**Flasche Talkumpulver Spartal 280 g****Talco 280 g**u.m.vta: 1  6 

280 g

REF. 01293



**RAGNAR**  
BARBER LINE**RAGNARTalkum****Talco RAGNAR**u.m.vta: 1  6 

200 g

REF. 06428

- Absorbiert Feuchtigkeit
- Hält die Haut kühl und trocken
- Beruhigt gereizte Haut
- Macht die Haut weich
- Allergen- & Parabenfrei, dermatologisch getestet
- GEBRAUCHSANWEISUNG: auf die Hände oder den Pinsel streuen und so oft wie nötig auftragen

- *Assorbe l'umidità*
- *Mantiene la pelle fresca e asciutta*
- *Lenisce la pelle irritata*
- *Ammorbidisce*
- *Privo di allergeni e paraben, dermatologicamente testato*

**Dose mit duftendem Talkumpulver****Latta di talco profumato**u.m.vta: 1  9 

300 g

REF. 06437

- Absorbiert Feuchtigkeit
- Hält die Haut kühl und trocken
- Beruhigt gereizte Haut und macht sie weich
- Keine Parabene oder Allergene
- Innovative und umweltfreundliche Verpackung
- Mit einem männlichen Aroma
- Innovative Verpackung

- *Assorbe l'umidità*
- *Mantiene la pelle fresca e asciutta*
- *Lenisce la pelle irritata e ammorbidisce*
- *Senza paraben o allergeni*
- *Packaging innovativo ed ecologico*
- *Con profumo maschile*



**Mehr  
Informationen  
Maggiori  
informazioni**

**SCAN  
ME!**



## Rasieret für Männer kit rasatura

Barber Line

u.m.vta: 1  24



REF.06177

Klassisches Rasieret für Männer, die auf das Vergnügen einer altmodischen Rasur nicht verzichten wollen. Es enthält einen Rasierer für eine präzise Rasur, einen ergonomischen Pinsel für den Komfort und eine Schale, ein unverzichtbares Werkzeug für jeden Barbier. Rasieren Sie sich auf die altmodische Art und Weise und erhalten Sie in nur wenigen Minuten eine perfekte und präzise Rasur.

*Kit rasatura classico per chi ama la raffinatezza e non vuole rinunciare al piacere della rasatura vecchio stile. Contiene un rasoio per una rasatura precisa, un pennello ergonomico che fornirà comfort e una bacinella, uno strumento indispensabile per qualsiasi barbiere. Raditi alla vecchia maniera e ottieni una rasatura perfetta e precisa in pochi minuti.*





## Spezialkamm Bart Pettine speciale per barba

u.m.vta: 1  12 

REF.06176



## Kleine und große Ragnar Bartbürste Spazzola per barba Ragnar piccola e grande

u.m.vta: 1  20 

REF.07285

RAGNAR  
BARBER LINE

NEW



REF.07286

## RAGNAR Nackenwedel aus Holz

### Spazzola per il collo RAGNAR in legno

u.m.vta: 1  14 

REF. 06070

RAGNAR Pinsel. Polierte Nylon-Borsten. Große Geschmeidigkeit und Schleppkraft. Ideal zum Entfernen von abgeschnittenen Haaren an Hals und Nacken.

*Spazzola da barbiere RAGNAR Setole smussate in nylon Grande morbidezza e forza di spazzolatura.*



## TRITON-Nackenwedel

### Spazzola TRITON

u.m.vta: 1  12 

REF. 06076



Das Design dieses Pinsels ist so gestaltet, dass nach jedem Schnitt die restlichen Haare am Nacken gefegt werden. Der TRITON-Pinsel besteht zu 100% aus Naturholz, während seine Borsten zu 100% synthetisch sind. Seine weichen Borsten nehmen die Haarreste ohne zu kratzen mit.

*La spazzola TRITON è realizzata in legno naturale al 100% mentre le sue setole sono sintetiche al 100%. Le sue setole morbide trascinano i resti dei capelli senza graffiare.*



## Nackenwedel mit polierten Borsten

### Spazzola da barbiere con setole smussate

u.m.vta: 1  18 

REF.06116

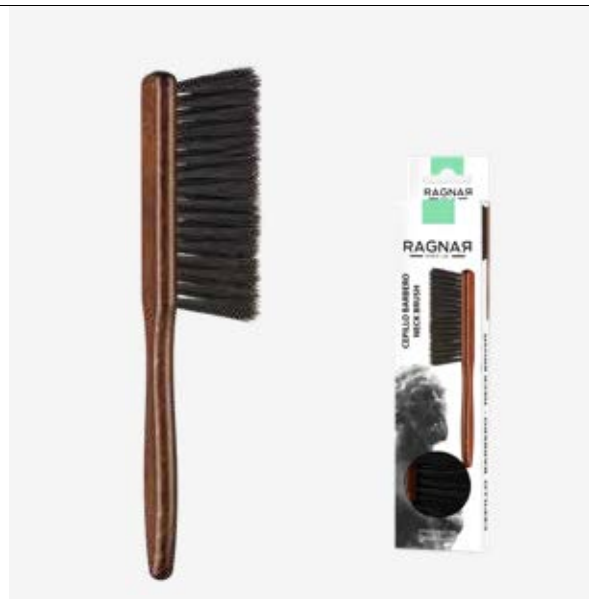

RAGNAR Bürste aus Holz. Mit Nylonborsten, die für große Geschmeidigkeit und Schleppkraft sorgen. Ideal zum Entfernen von abgeschnittenen Haaren im Nacken und Nackenbereich.

*Spazzola da barbiere RAGNAR in legno Con setole in nylon, che forniscono grande morbidezza e forza di spazzolatura.*



## Bartbürste POSEIDON

### Spazzola da barba POSEIDON

u.m.vta: 1  12 

**REF. 06078**

Sein abgerundetes Design passt perfekt in die Handfläche, so dass Sie den Bart bequem kämmen können. Die POSEIDON-Bürste besteht zu 100% aus Naturholz. Seine Borsten, 50 % natürlich und 50 % Nylon, sorgen für jenen Hauch von Weichheit, den der natürliche Borsten nicht bietet.

*Il suo design arrotondato si adatta perfettamente al palmo della mano permettendo di pettinare comodamente la barba. La spazzola POSEIDÓN è realizzata al 100% in legno naturale. Le sue setole, 50% naturali e 50% in nylon, danno quel tocco di morbidezza che la setola naturale non offre.*





10 cm



## TALASA- Bartbürste

### Spazzola da barba TALASA

u.m.vta: 1  12 

**REF. 06073**

Diese kleine Bürste ohne Stiel und abgerundeter Form ist perfekt für diese kurzen Bärte. Dank seiner geringen Größe können wir auch schwer zu durchkämmende Bereiche wie den Schnurrbartbereich erreichen. Die TALASA-Bürste besteht zu 100% aus Naturholz. Seine Borsten, 50 % natürlich und 50 % Nylon, sorgen für jenen Hauch von Weichheit, den der natürliche Borsten nicht bietet.

*Spazzola piccola senza manico e dalla forma arrotondata è perfetta per le barbe corte. Le sue dimensioni ridotte ci permettono di raggiungere quelle zone difficili da pettinare come la zona dei baffi. La spazzola TALASA è realizzata al 100% in legno naturale. Le sue setole, 50% naturali e 50% in nylon, danno quel tocco di morbidezza che la setola naturale non offre.*



8 cm



## APOLO Bartbürste

### Spazzola da barba APOLO

u.m.vta: 1  12 

**REF. 06077**

Das Design dieser Bürste ist für jene dichten Bärte gedacht, die schwer zu kämmen sind. Seine große Größe erlaubt es, breite und dicke Bereiche unseres Bartes zu bürsten. Die APOLO-Bürste besteht zu 100% aus Naturholz. Seine 50 % natürlichen Borsten und 50 % Nylon sorgen für jenen Hauch von Weichheit, den der natürliche Borsten nicht bietet.

*Il design di questa spazzola è pensato per quelle barbe folte e difficili da pettinare. Le sue ampie dimensioni consentono di spazzolare aree ampie e folte della nostra barba. La spazzola APOLO è realizzata al 100% in legno naturale. Le sue setole, 50% naturali e 50% in nylon, danno quel tocco di morbidezza che la setola naturale non offre.*

15 cm



## OCEANO Bartbürste

### Spazzola da barba OCEANO

u.m.vta: 1  12 

**REF. 06075**

Das Design dieser Bürste ist für die Haar- und Bartpflege konzipiert. Die OCEANO-Bürste besteht zu 100% aus Naturholz. Seine 50 % natürlichen Borsten und 50 % Nylon sorgen für jenen Hauch von Weichheit, den der natürliche Borsten nicht bietet.



*Il design di questa spazzola è concepito per la cura della barba. La spazzola OCEANO è realizzata al 100% in legno naturale. Le sue setole, 50% naturali e 50% in nylon, danno quel tocco di morbidezza che la setola naturale non offre.*

20 cm



### NEREO Bartbürste aus Holz

#### Spazzola da barbiere in legno NEREO

u.m.vta: 1  12 

REF. 06072

Diese kleine Bürste mit Holzgriff eignet sich perfekt für kurze Bärte. Sein Griff ermöglicht es Ihnen, kleine Bereiche wie den Schnurrbart zu kämmen. Der Pinsel NEREO besteht aus 100% Naturholz. Seine 50 % natürlichen Borsten und 50 % Nylon sorgen für jenen Hauch von Weichheit, den der natürliche Borsten nicht bietet.



*Questa piccola spazzola con manico in legno è perfetta per le barbe corte. Il suo manico permette di pettinare piccole zone come i baffi. La spazzola NEREO è realizzata al 100% in legno naturale. Le sue setole, 50% naturali e 50% in nylon, danno quel tocco di morbidezza che la setola naturale non offre.*

11,5 cm



### Kleiderbürste GORGONAS

#### Spazzola per abiti GORGONAS

u.m.vta: 1  12 

REF. 06074

Diese Bürste wurde entwickelt, um die Haarreste zu entfernen, die nach dem Schnitt an der Kleidung haften. Die GORGONAS-Bürste besteht zu 100% aus Naturholz und ihre Borsten bestehen zu 100% aus Nylon. Seine robusten Borsten schleppen Haare und Schmutz weg und hinterlassen saubere Kleidung. Sein ergonomischer Griff ermöglicht einen bequemen Umgang mit der Bürste während der Arbeit.

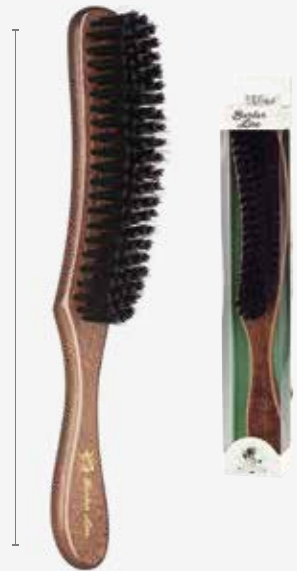

*Questa spazzola è stata progettata per rimuovere i residui di capelli intrappolati negli indumenti dopo il taglio. La spazzola GORGONAS è realizzata al 100% in legno naturale e le sue setole sono al 100% in nylon. Le sue setole robuste spazzolano via capelli e sporco, lasciando i vestiti puliti. La sua impugnatura ergonomica consente una comoda presa della spazzola durante la spazzolatura.*

27 cm



### Fade Bürste: für Stufenbart

#### Spazzola Fade: per sfumature da barbiere

u.m.vta: 1  24 

REF. 04976



Kunststoffbürste mit weichen Nylon Borsten, ideal für "Fade"-Schnitte

*Spazzola in plastica con setole morbide in nylon ideale per tagli "fade"*

15 cm



### Barbier-Nackenwedel Spazzola per il collo



u.m.vta: 4  40 

REF. 00501



- Kunststoffgriff
- Bündeln: Nylon
- Manico in plastica
- Setole in nylon





u.m.vta: 1  18 

REF. 00595

- Holzgriff
- Bündeln: Nylon
- Manico in legno
- Setole in nylon



### Große Bartbürste Spazzola grande



u.m.vta: 1  14 

REF. 00306

- Kunststoffgriff
- Bündeln: Nylon
- Manico in plastica
- Setole in nylon



### Wildschwein reine Flache Bürste Spazzola piatta puro cinghiale



u.m.vta: 1  12 

REF.00599

- Natürliches Wildschweinhaar
- Setole naturali di cinghiale



### Balgbürste mit Holzgriff und Wildschweinborsten Spazzola curva scheletro



u.m.vta: 1  12 

REF. 00352

- Holzgriff
- Naturborsten vom Wildschwein
- Manico in legno
- Setole naturali di cinghiale



### Gebogene Skelettbürste Spazzole curve a scheletro

u.m.vta: 12  96 

REF. 02195/50



- Kunststoffzinken mit Kugel
- Setole in plastica con punte arrotondate





### Antistatische Skelett-Bürsten Spazzole a scheletro antistatica





u.m.vta: 1		12	
------------	---	----	---

REF.00584

- Nylonzinken mit Kugel
- Setole in nylon + punte arrotondate



### Doppelte Skelettbürsten Spazzole doppie a scheletro

u.m.vta: 24		24	
-------------	---	----	---





REF. 02182



REF. 02182/50



### Fade Bürste: für Stufenbart Spazzola Fade: per sfumature da barbieri

u.m.vta: 1		24	
------------	---	----	---

REF. 04977

Kunststoffbürste mit weichen Nylonbündeln, ideal für "Fade"-Schnitte

Spazzola in plastica con setole morbide in nylon ideale per tagli "fade"





05

## Kämme Pettini

*Barber Line Kämme, Captain Cook Kämme, Eurostil  
Kämme, Silkomb Kämme...*

*Pettini Barber Line, Pettini Captain Cook, Pettini  
Eurostil, Pettini Silkomb...*

**Barbierkamm Schneiden**  
*Pettine da barbiere taglio*

u.m.vta: 12 72



Schwarz  
Nero

REF.07356



Elfenbein  
Avorio

REF.07356/82



Klassisch  
Classico

REF.07356/98

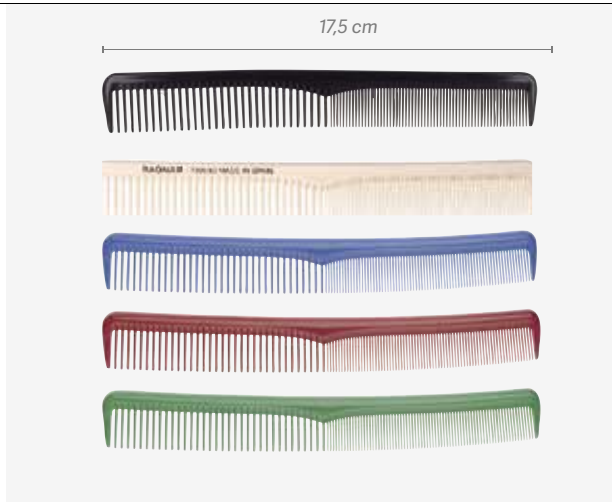

**Barbierkamm**  
*Pettine da barbiere*

u.m.vta: 12 72



Schwarz  
Nero

REF.07355



Elfenbein  
Avorio

REF.07355/82



Klassisch  
Classico

REF.07355/98

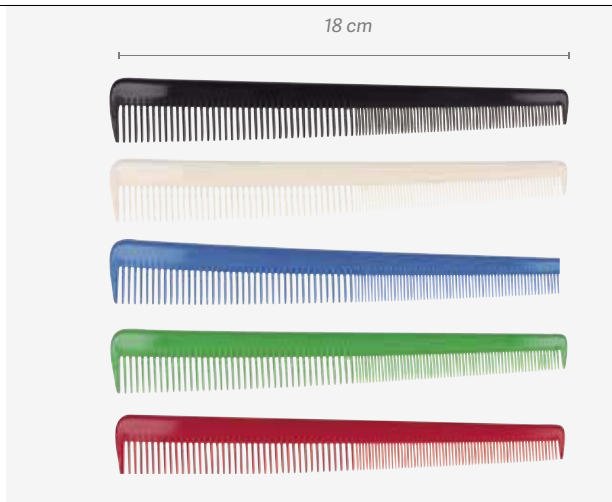

u.m.vta: 12 72



Schwarz  
Nero

REF.07357



Elfenbein  
Avorio

REF.07357/82



Klassisch  
Classico



REF.07357/98



## Barbierkamm Schneidekamm

### Pettine da barbiere tartaruga



**RAGNAR**  
 BARBER LINE

 u.m.vta: 12  72 

-   
 • Schwarz  
 • Nero
  -   
 • Elfenbein  
 • Avorio
  -     
 • Klassisch  
 • Classico
- MOD. 04616

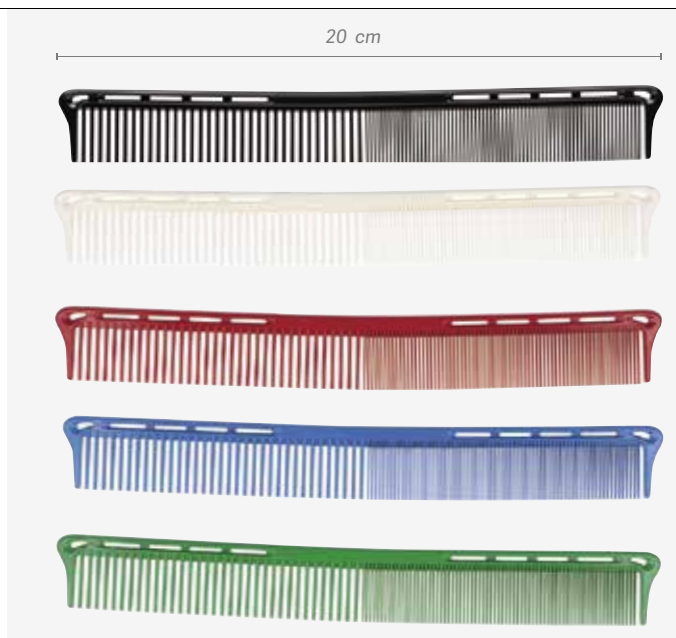

MOD. 04616/82

MOD. 04616/98
- REF.07358      REF.07358/82      REF.07358/98

 u.m.vta: 12  72 

- MOD. 00113
- Nylon
  - Negro
  - Nylon
  - Black
- REF.07359

- MOD. 00424
- Schwarz
  - Nero
- REF.07360

 u.m.vta: 12  48 

- MOD. 00454
- Richtig
  - Schwarz
  - Giusto
  - Nero
- REF.07361



- MOD. 00455
- Dochte
  - Schwarz
  - Stoppini
  - Nero
- REF.07362



## Carbon-Kamm RAGNAR

### Pettini in carbonio RAGNAR

**RAGNAR**  
 BARBER LINE

 u.m.vta: 12  72 

MOD. 02216

- Schneidekamm
- Pettine da taglio

REF.07367

MOD. 02215

- Speziell
- Speciale

REF.07368



## Barbierkamm Schneiden speziell

### Pettine da barbieri taglio speciale

 u.m.vta: 12  60 

MOD. 02183

- Spezial-Schneidekamm für Maschinenschnitt
- Pettine taglio speciale macchina prof.

REF.07363

MOD. 06802

REF.07364





MOD. 06802/82

- Spezial-Schneidekamm für Maschinenschnitt
- Pettine taglio speciale macchina prof.

REF.07364/82

## Barbierkamm Schneiden Fingerkamm Pettine da barbiere districante afro

u.m.vta: 12  60 



MOD. 00419/50

- Schwarz
- Nero

REF.07365/50



## Haar Dichte Stoppini

u.m.vta: 12  48 

MOD. 00409/50

- Schwarz
- Nero

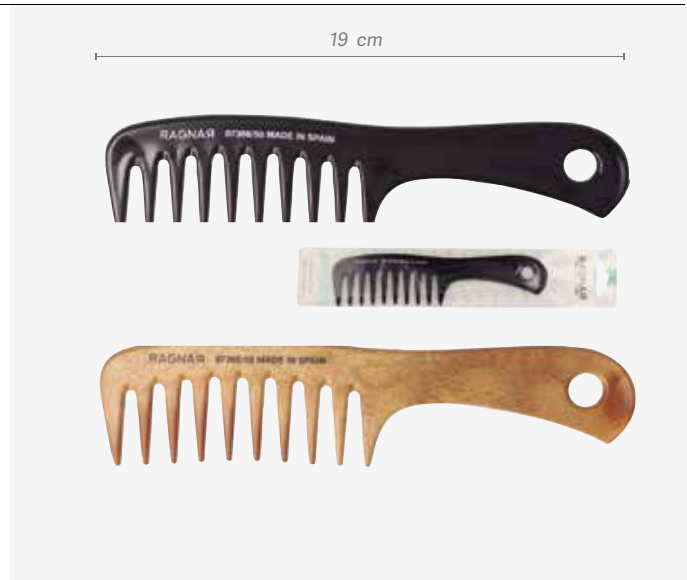

REF.07366/50



MOD. 00409

REF.07366/55

## Haar Dichte Stoppini

u.m.vta: 12  48 

REF.07602

- Doppelzinken
- Doppio dente

**NEW**



## CAPTAIN COOK Kammlinie

### Linea pettine CAPTAIN COOK



u.m.vta: 12 72

**REF. 04981**

- Kohlenstoff
- Carbonio

19,5 cm



18 cm



**REF.07441**

- Schwarz
- Nero



**REF.07441/82**

- Elfenbein
- Avorio



u.m.vta: 12 72

**REF.07442**

- Schwarz
- Nero

19,5 cm



**REF.07442/82**



- Elfenbein
- Avorio



## CAPTAIN COOK Kammlinie

### Linea pettine CAPTAIN COOK



u.m.vta: 12  60 

REF.07443



20,5 cm



REF.07443/82

- Haar Dichte / Schwarz
- Stoppini - Nero





u.m.vta: 12  48 

REF.07444

19 cm



u.m.vta: 12  60 

REF.07474

**NEW**



REF.07474/82







**Holz-kamm Schnurrbart**  
*Pettine barba-baffi in legno*

u.m.vta: 12 60

**REF.04548**

- Breit
- Larghezza

**SPEZIELL BART & SCHNURRBART**  
*SPECIALE BARBA E BAFFI*



u.m.vta: 12 96

**REF.04549**

- Mit Griff
- Con manico



**Bart-Schnurrbart-Kamm Muscheleffekt**  
*Pettine tartaruga barba-baffi*

u.m.vta: 12 120

**REF.04546**

- Langer Stiel
- Manico lungo



**REF.04547**

- Langer Stiel
- Manico lungo



u.m.vta: 12 96

**REF.04545**

- Faltbar
- Pieghevole



## Eurostil Profi-Schlägerkamm

### Pettine da taglio professionale Eurostil

u.m.vta: 12 72



REF. 00115

- Spezielle Zahnung
- Punta speciale

17,5 cm



REF. 00442

- Spezielle Zahnung
- Punta speciale

17,5 cm



REF. 00441

- Spezielle Zahnung
- Punta speciale

17,5 cm



REF. 00424

- Spezial verstärkt
- Speciale rinforzato

18,5 cm



REF. 00116

- Groß
- Grande

19,5 cm



REF. 01470

- Superlang
- Super lungo

21,5 cm



## Spezieller Friseurkamm

### Pettine speciale per parrucchieri



REF. 00422





REF. 00422/58

18 cm



## Carbonbürsten Pettini in carbonio

u.m.vta: 12  72 

**REF. 02186**

- Schneidekamm
- Pettine da taglio

17,5 cm



**REF. 02214**

- Spezielle Zahnung
- Punta speciale

17,5 cm



**REF. 02215**

- Speziell für Friseure
- Pettine speciale da parrucchiere

18 cm





**REF. 02216**

- Schneidekamm
- Pettine da taglio

19,5 cm



u.m.vta: 12  48 

**REF. 02188**

- Mod. GERADE
- Mod. DRITTO

19,5 cm



u.m.vta: 12  72 

**REF. 02187**



- Spezielle Zahnung
- Punta speciale

20,5 cm



**SILKOMB Profi-Kamm**  
**Pettini professionale SILKOMB**

**SILKOMB™**

u.m.vta: 1  50 

PRO-10

REF. 01520

24 cm

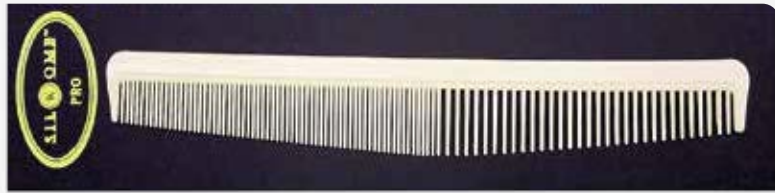

PRO-40

REF. 01524

23 cm

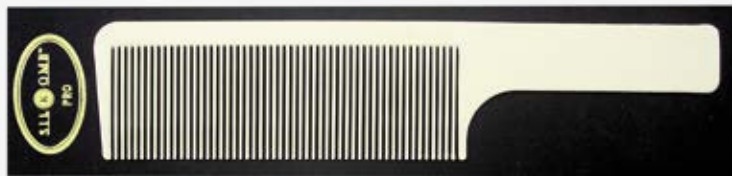

PRO-50

REF. 01525

22,5 cm



PRO-20

REF. 01522

19 cm



PRO-30

REF. 01523

19 cm



PRO-11



REF. 01521

17,5 cm



## Kamm mit Wasserwaage

### Pettine con livelle

u.m.vta: 1  120 



REF. 04349



- Kamm mit Wasserwaage
- Es erlaubt einen perfekten Schnitt oder Maßstab in einer geraden Linie dank seiner 3 Wasserwagen
- *Pettine con livelle*
- *Consente di tagliare o scalare in perfetta linea retta grazie alle 3 livelle*

## Kamm-Reinigungsbürste

### Spazzola per la pulizia del pettine

u.m.vta: 1  100 

REF. 00600



06



## Kosmetik Cosmetici

Haarkosmetik, Bartkosmetik,  
Fixierkosmetik...

Cosmetici per capelli, cosmetici per barba, cosmetici fissanti...



## Ragnar haaransatz-färbemittel 75 ml für kopf- und barthaare Ritocca-radici Ragnar 75 ml per capelli e barba

u.m.vta: 1  12 

REF. 07475/50



• Schwarz  
• Nero

REF. 07475/65



• Hellbraun  
• Marrone chiaro

REF. 07475/67



• Dunkelbraun  
• Marrone scuro

- Vorübergehende Färbung in Sprayformat.
- Überdeckt Ansätze und graue Haare sofort.
- Colorazione temporanea in spray.
- Copre istantaneamente radici e capelli grigi.

## Aufsteller ansatzspray Ragnar Espositore roots-retouch Ragnar

u.m.vta: 1  1

REF. 07582

Leer  
Vuoto  
REF. 07582/01





NEW





## Shampoo für empfindliche Kopfhaut Shampoo per cuoio capelluto sensibile

u.m.vta: 1  4250 ml 

REF. 04963

u.m.vta: 1  2 500 ml 

REF. 07374

u.m.vta: 1  6 1L 

REF. 07375



### Regulierung Kopfhaut

Mit milden Tensiden mit hohem Benetzungsvermögen, so dass die Oberflächenspannung des Wassers herabgesetzt wird. Aufgrund seiner aktiven Inhaltsstoffe besitzt es haarkonditionierende Eigenschaften, um das Haar leichter kämmbar zu machen, liefert Feuchtigkeit, um das Gefühl von Trockenheit und Brüchigkeit zu überwinden, kontrolliert die Produktion toter Zellen auf der Kopfhaut und besitzt antibakterielle und antimykotische Wirkung. Ideal für empfindliche Haare und Kopfhaut.



### Regolatore del cuoio capelluto

Grazie ai suoi principi attivi possiede proprietà che facilitano lo styling, fornisce idratazione per superare la sensazione di secchezza e fragilità, controlla la produzione di cellule morte sul cuoio capelluto ed esercita una attività antibatterica e antimicotica. Ideale per capelli e cuoio capelluto sensibili.



## Silber-Shampoo für graues Haar Shampoo silver per capelli grigi

u.m.vta: 1  4250 ml 

REF. 04965

u.m.vta: 1  2 500 ml 

REF. 07376

u.m.vta: 1  6 1L 

REF. 07377

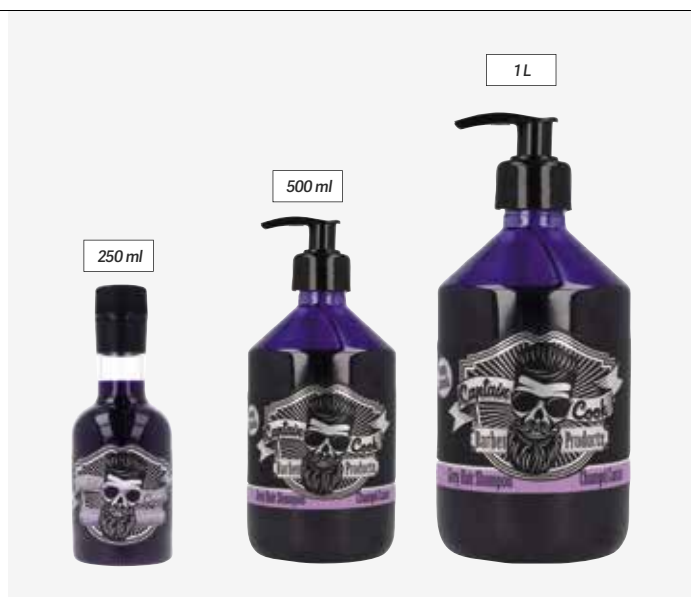

### Für graues Haar

Mit milden Tensiden mit hohem Benetzungsvermögen, so dass die Oberflächenspannung des Wassers herabgesetzt wird. Aufgrund seiner aktiven Inhaltsstoffe pflegt es das Haar, um es leichter kämmbar zu machen, und mit Pigmenten pflanzlichen Ursprungs, die Farbveränderungen bei grauem Haar verhindern und den Glanz wiederherstellen. Speziell für graues Haar, vermeidet und verdeckt den gelblichen Ton.





### Per capelli grigi

Grazie ai suoi principi attivi ammorbidisce i capelli per facilitarne lo styling e grazie ai pigmenti di origine vegetale che impediscono il cambiamento di colore nei capelli grigi ravviva la loro lucentezza. Speciale per capelli grigi, in quanto evita e copre i toni giallastri.



## Erfrischendes Shampoo

### Shampoo rinfrescante

u.m.vta: 1		2		u.m.vta: 1		6	
------------	---	---	---	------------	---	---	---

500 ml	PH 5.5	1L	PH 5.5
--------	--------	----	--------

REF. 07370

REF. 07371

Besonders geeignet zur Vorbeugung und Bekämpfung von Haarausfall, zur Stimulierung der Kopfhaut und für neue Vitalität. Es reduziert den Talg und gibt dem Haar seinen natürlichen Glanz zurück.

*Particolarmente indicato per prevenire e combattere la caduta dei capelli, stimolando il cuoio capelluto e donando rinnovata vitalità. Riduce il sebo, restituendo ai capelli la loro naturale lucentezza.*







## Balsam

### Crema emolliente

u.m.vta: 1		4
------------	---	---

250 ml	PH 5.5
--------	--------

REF. 04870

u.m.vta: 1		2		u.m.vta: 1		6	
------------	---	---	---	------------	---	---	---

500 ml	PH 5.5	1L	PH 5.5
--------	--------	----	--------

REF. 07372

REF. 07373





Ergänzung zum Shampoo. Es enthält erfrischende und stimulierende Eigenschaften der Kopfhaut und gibt ihr ihre natürliche Feuchtigkeit und ihren Glanz zurück.

*Complemento per shampoo. Combina proprietà rinfrescanti e stimolanti per il cuoio capelluto, ripristinandone l'idratazione e la lucentezza naturale.*



### Modellierpomade zur Fixierung, sanft Cera modellante per una tenuta delicata



u.m.vta: 1  6 

200 ml

100 ml

REF. 04867

REF.06232

u.m.vta: 1  16 

50 ml



REF.06233



Ideal für anspruchsvolle Stile, die gut aussehen wollen. Bietet Glanz und einen weichen, flexiblen Halt ohne Rückstände zu hinterlassen. Auf Wasserbasis, so dass es dem Haar Weichheit und Hydratation verleiht.

*Ideale per stili esigenti che vogliono avere un look perfetto. Fornisce lucentezza e una tenuta morbida e flessibile senza lasciare residui. A base d'acqua, dona morbidezza e idratazione ai capelli.*

### Modellierpomade zur Fixierung, mittel Cera modellante per una tenuta media



u.m.vta: 1  6 

200 ml

100 ml

REF. 06229

REF.06230

u.m.vta: 1  16 

50 ml



REF.06231



Leicht aufzutragendes Cremewachs zur Pflege und Definition der gewünschten Frisur. Mit natürlichen Wachsen und Sheabutter, die das Haar schützen und pflegen. Natürliches, mattes Finish für jede Art von Frisur.

*Cera cremosa di facile applicazione per mantenere e definire l'acconciatura desiderata. Con cere naturali e burro di karité che proteggono e si prendono cura dei capelli. Finitura opaca naturale per qualsiasi tipo di acconciatura.*

### Modellierpomade zur Fixierung, stark Cera modellante per una tenuta forte



u.m.vta: 1  6 

200 ml

100 ml

REF. 04866

REF.06236

u.m.vta: 1  16 

50 ml

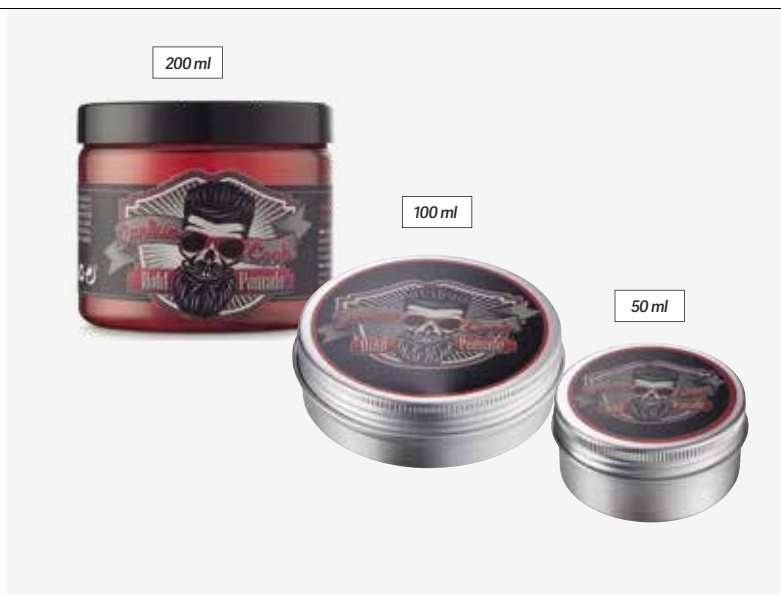

REF.06237



Pomade Verleiht Glanz und starken Halt, lässt das Haar jedoch flexibel und leicht rückstandsfrei zu entfernen. Auf Wasserbasis, die dem Finish Weichheit und Hydratation verleiht.

*Dona lucentezza e tenuta forte ma lascia i capelli flessibili, facile da rimuovere senza lasciare residui. A base d'acqua, dona morbidezza e idratazione ai capelli.*

### MATT RUBBER Pomade Cera per styling Rubber Matt



u.m.vta: 1  6 

200 ml

100 ml

REF. 04868

REF.06234

u.m.vta: 1  16 

50 ml

REF.06235





Mattes Pomade Stylingwachs die dem Haar Form und Volumen für eine lang anhaltende Frisur verleiht. Schnell trocknend und mattes Finish. Hinterlässt keine Rückstände. Aufgrund seiner Zusammensetzung, die reich an natürlichen Wachsen ist, verleiht es dem Haar Weichheit und Schutz.

*La cera fissante per styling Rubber Mate permette di dare forma e volume ai capelli, ottenendo un'acconciatura di lunga durata. Asciugatura rapida e finitura opaca. Non lascia residui. Grazie alla sua composizione, ricca di cere naturali, dona morbidezza e protezione ai capelli.*

## SPIDER GUM Pomade

### Cera modellante a tenuta leggera Spider Gum



u.m.vta: 1  6 

200 ml

100 ml

REF. 06677

REF.06678

u.m.vta: 1  16 

50 ml

REF.06679





Faseriges Wachs zum Formen und Strukturieren von Haar. Starker Halt, langlebig und leicht zu entfernen. Auftragen: eine kleine Menge des Produkts zwischen den Händen reiben, mit der Reibung der Hände erwärmen, um die Fasern zu aktivieren, und auf das Haar auftragen und ihm die gewünschte Form geben.

*Cera fibrosa per modellare e strutturare i capelli. Tenuta a lunga durata e facile da rimuovere. Metodo di applicazione: applicare una piccola quantità di prodotto tra le mani, riscaldare con la frizione delle mani per attivare le fibre e applicare sui capelli, dando loro la forma desiderata.*

## Fixierspray Gravity Zero

### Spray Gravity Zero effetto secco

u.m.vta: 1  10 



125 ml

REF. 04961

**Gravity Zero:** dank seiner Zusammensetzung hinterlässt es einen unsichtbaren Trockeneffekt-Film auf dem Haar mit großem Volumen und hoher Feuchthaltekraft. Ideal für jeden Haartyp, verleiht ihm Glanz. Leistungsstark auch bei hoher Luftfeuchtigkeit und Temperatur. Direkt auf das Haar sprühen und wie gewünscht stylen.

*Gravity Zero: grazie alla sua composizione, lascia sui capelli una patina invisibile dall'effetto secco e grande volume con potere idratante. Ideale per qualsiasi tipo di capello donando luminosità. Potente anche in condizioni di umidità e temperature elevate. Spruzzare direttamente sui capelli e pettinare secondo lo stile desiderato.*



**Professioneller haarlack kräftig****Lacca professionale forte**u.m.vta: 1  12 

300 ml

REF.07129

Verleiht Ihrem Haar eine ausgezeichnete Fixierung und einen natürlichen Glanz und schützt es zugleich vor äußeren Einflüssen wie Wind, Feuchtigkeit usw.

Erhält die Frisur perfekt während des gesamten Tages. Long-lasting-Effekt. Einfach zu entfernen durch leichtes Bürsten. Stärkt die Haarfaser.

*Dona ai tuoi capelli un'ottima tenuta e una lucentezza naturale proteggendoli dagli agenti esterni come vento, umidità, ecc. Mantiene l'acconciatura perfetta per tutto il giorno. Effetto duraturo. Si rimuove facilmente con una leggera spazzolatura. Rafforza la fibra capillare.*



**Ökologisches Haarspray****Lacca ecologica**u.m.vta: 1  24 

300 ml

REF.07113

Captain Cook Haarspray ist ideal für strukturiertes Arbeiten, es respektiert das Haar dank der Wirkung des Provitamins B5. Seine mikrofeine Diffusion überlastet das Haar nicht und lässt sich beim Bürsten leicht entfernen.

*Captain Cook Hair Spray, rispetta i capelli grazie all'azione della provitamina B5. La sua diffusione micro-fine non sovraccarica i capelli.*

**Locken-gel captain cook****Gel riccioli captain cook**u.m.vta: 1  24 

250 ml

REF.07378

Die Creme zur Definition von Locken ist speziell dafür zusammengestellt, um auf einfache und bequeme Weise Locken und Wellen im Haar zu gestalten. Die Weizenproteine sorgen für Hydratisierung und Glanz und verhindern das Kräuseln. Formen Sie Ihren Look mit den Fingern. Für eine optimale Definition der Locke an der Luft oder mit dem Diffuser trocknen lassen.

**Vorteile**

- Lockendefinition
- Maximale Hydratation
- Volumen

*Questa crema per la definizione ricci è appositamente formulata per disegnare ricci e onde nei capelli in modo facile e confortevole. Le proteine del grano forniscono idratazione e lucentezza, prevenendo l'effetto crespo. Dai forma al tuo look con le dita. Lascia asciugare all'aria o con un diffusore per una definizione ottimale dei riccioli.*



**Benefici**

- Definizione dei ricci
- Massima idratazione
- Volume



## Volumenpulver Gravity Powder

### Polverevolumizzante Gravity Powder



u.m.vta: 1  15 

10 g

- Mit Zerstäuber
- Con sprayer

REF. 06473

Bestes  
preisgekröntes  
Produkt des Jahres  
Premio per il  
miglior prodotto  
dell'anno

u.m.vta: 1  20 

20 g

REF. 04962



**Gravity Powder:** ultraleichtes texturiertes Mattierungspulver verleiht dem Haar großes Volumen, wobei die Anwendung durch minimales Massieren der Haarwurzel einfach ist. Ideal zum Fixieren stark strukturierter Frisuren. Weicher Matteeffekt. Dank seiner Wirkstoffe fettet es selbst bei anfälligem Haar nicht und hilft, überschüssigen Talg zu absorbieren. Kontrolle und Langanhaltender Halt.

*Gravity Powder: polvere opacizzante texturizzante ultraleggera. Dona grande volume ai capelli con la sua facile applicazione con un semplice massaggio dalla radice del capello. Ideale per fissare acconciature molto strutturate. Con leggero effetto opaco. Grazie ai suoi principi attivi non unge i capelli, anche su quelli inclini a diventarli, aiutando ad assorbire la seborrea in eccesso. Tenuta a lunga durata.*

## Bourbon-Shampoo 1874

### Shampoo Bourbon 1874

u.m.vta: 1  2

5 L

REF. 07096

Speziell erstelltes Shampoo für harte Männer, die ihr Haar sauber, glänzend und widerstandsfähig halten wollen. Spezifisch für alle Haar- und Kopfhauttypen. Geeignet für den täglichen oder häufigen Gebrauch. Schützt Haar und Kopfhaut und verleiht ihnen Ausgeglichenheit und Gesundheit

*Shampoo appositamente formulato per "uomini duri" che vogliono mantenere i capelli puliti, lucenti e resistenti. Specifico per tutti i tipi di capelli e cuoio capelluto. Indicato per un uso quotidiano o frequente. Protegge i capelli e il cuoio capelluto donando equilibrio e salute.*



## Packung Bart

### Kit Barba

u.m.vta: 1  4

REF. 06668

Enthält 250 ml Bart-Shampoo  
+ 30 ml Bartöl + 50 ml Bartwachs

*Include 250 ml di shampoo per barba  
+ 30 ml di olio da barba + 50 ml di cera  
da barba*



## Packung Haar

### Kit Capelli

u.m.vta: 1  4

REF. 06669

Enthält 250 ml Erfrischungsshampoo + 20  
g Gravity Powder + 50 ml Bartwachs matt

*Include 250 ml di shampoo rinfrescante  
+ 20 g di Gravity Powder + 50 ml di cera  
opaca*



u.m.vta: 1  10

REF. 07079

Kulturbeutel Leer  
Beaty case vuoto



### Rasieröl Vorbehandlung Olio pre-rasatura

u.m.vta: 1  6 

30 ml



REF. 04860



Für eine angenehme Rasur. Speziell entwickeltes Produkt zur Behandlung der Haut vor der Rasur.. Enthält erfrischende Wirkstoffe, die das sichere ziehen der Klinge unterstützen.

*Per una piacevole esperienza di rasatura. Prodotto appositamente studiato per trattare la pelle prima della rasatura. Contiene attivi rinfrescanti che aiutano a far scorrere la lama in sicurezza.*

### Bart-Öl Olio da barba

u.m.vta: 1  6 

30 ml



REF. 04861



Gesunder und angenehmer Bart. Mischung aus natürlichen Ölen, die das Barthaar nähren und ihm Feuchtigkeit spenden und dazu beitragen, ihn gesund und angenehm zu halten. Nicht fettend.

*Barba sana e gestibile. Miscela di oli naturali che nutrono e idratano i peli della barba aiutando a mantenerli sani e pettinabili. Non unge.*

### Bartwachs Cera da barba

u.m.vta: 1  6 

50 ml



REF. 04865



Meistern Sie Ihren Bart. Hohe Konzentration natürlicher Wirkstoffe wie Arganöl und Hagebuttenöl, die das Haar in der Tiefe schützen und nähren, ohne ein fettiges Gefühl zu vermitteln.

*Alta concentrazione di principi attivi naturali come olio di argan e rosa canina, che proteggono e nutrono.*

### Bart-Shampoo Shampoo da barba

u.m.vta: 1  6 

250 ml

PH 5.5



REF. 04862



Tiefenreinigung. Reinigungsseife mit feuchtigkeitsspendenden und weichmachenden Eigenschaften. Erzeugt einen dichten Schaum, der Verunreinigungen weglöst.

*Pulizia profonda. Shampoo detergente con proprietà idratanti ed emollienti. Produce una schiuma densa che elimina le impurità.*

### Rasierschaum Schiuma da barba

u.m.vta: 1  6 

250 ml

PH 5.5



REF. 04863



Rasieren ist einfach... Erstellt mit sanften, feuchtigkeitsspendenden Wirkstoffen zum Schutz der Haut. Speziell entwickelt, um die Poren zu öffnen, die Haut mit Feuchtigkeit zu versorgen und den Bart weicher zu machen, um die Rasur zu erleichtern.

*Radersi è facile... Formula a base di principi attivi delicati e idratanti che proteggono la pelle. Appositamente progettato per aprire i pori, idratare la pelle e ammorbidire la barba per una facile rasatura.*

### Rasiercreme Nachbehandlung Crema dopobarba

u.m.vta: 1  6 

250 ml

PH 5.5

REF. 04864



Ideal für empfindliche Haut. Seine regenerierenden und beruhigenden Komponenten machen es ideal für das After-Shave und sorgen für ein angenehmes Gefühl von Frische und Feuchtigkeit.

*Ideale per pelli sensibili. Le sue componenti rigeneranti e lenitive lo rendono ideale per il dopobarba, donando una piacevole sensazione di freschezza e idratazione.*

## Aussteller Pomade von Captain Cook

### Espositore per pomate Captain Cook

u.m.vta: 1  1

REF.06441

- 6 Pomaden von jedem Ref. (50 ml und 100 ml)
  - GESCHENK: Holzaussteller, 2 Poster, 25 Kataloge, 1 Tasche, 1 Mütze
  - T-Shirts, 1 Mütze, 1 Tasche, 25 Kataloge, 2 Poster
- 6 pomate di ogni REF. (50 ml e 100 ml)
  - REGALO: espositore in legno, 2 poster, 25 cataloghi, 1 borsa, 1 cappello
  - magliette, 1 cappello, 1 borsa, 25 cataloghi, 2 poster



REF.06441/01

Aussteller Leer  
Espositore vuoto





## Aussteller Groß Captain Cook für Bart und Haare

### Espositore grande per barba e capelli Captain Cook

u.m.vta: 1  1

REF.04944

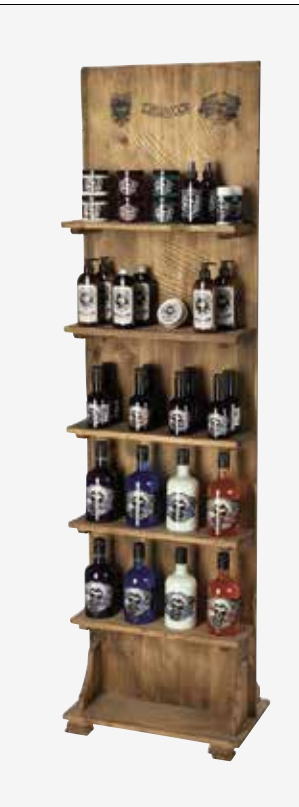
- 2 Stück je Referenz
  - GESCHENK: Holzaussteller, 8 T-Shirts, 2 Mützen, 2 Taschen, 50 Kataloge und 5 Poster
- 2 unità di ogni referenza
  - IN REGALO: espositore in legno, 8 magliette, 2 cappellini, 2 borse, 50 cataloghi e 5 poster

u.m.vta: 1  1

REF.04944/01

Aussteller Leer  
Espositore vuoto

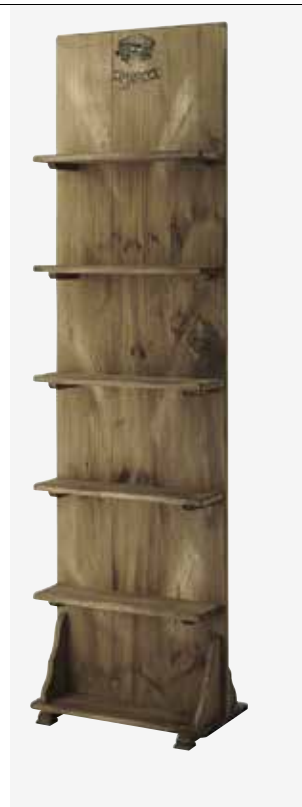





THE SHAVING CO. ist ein 100%iges mexikanisches Lifestyle-Konzept, das den modernen Mann definiert, mit einer Kollektion handgefertigter Körperpflegeprodukte für Männer, die mit der besten Technologie und den hochwertigsten Inhaltsstoffen entwickelt wurden, die unsere Produkte weltweit vertreiben. Seit 2014 verbindet THE SHAVING CO. die perfekte Erfahrung unserer exklusiven Friseurläden mit der Kreativität unserer Künstler und Designer, die mit Produkten und Behandlungen für die Herrenhaarpflege immer an vorderster Front stehen.

THE SHAVING CO. ist eine einzigartige und unvermeidliche Erfahrung, die "Männlichkeit" mit "Lebensstil" in Einklang bringt, von optimaler Pflegegestaltung, basierend auf Wohlbefinden und Umweltschutz.

Unsere Sammlung von 25 Produkten wird in vier speziellen Serien präsentiert:

HAAR-SERIE STYLING MEISTERWERKE NOXIDIL R-SERIE  
BART-SERIE  
RASIER-SERIE

*The SHAVING CO. è un concetto di stile di vita 100% messicano che definisce l'uomo moderno, con una collezione di prodotti per la cura personale maschile fatti a mano, sviluppati con la migliore tecnologia e ingredienti di altissima qualità con cui vengono ideati i nostri prodotti in tutto il mondo. Dal 2014 THE SHAVING CO. unisce la perfetta esperienza dei nostri esclusivi barbieri alla creatività dei nostri artisti e designer, sempre all'avanguardia grazie ai prodotti e ai trattamenti per la cura dei capelli maschili.*

*SHAVING CO. è un'esperienza unica e imprescindibile che armonizza "mascolinità" con "stile di vita" a partire dalla creazione di una cura ottimale basata sul benessere al rispetto dell'ambiente.*

*La nostra collezione di 25 prodotti è presentata in quattro serie specializzate:*

HAIR SERIES STYLING MASTERPIECES NOXIDIL R SERIES  
BEARD SERIES  
SHAVING SERIES



## After shaves Splash Lozioni dopobarba

u.m.vta: 1  5

The Shaving Co. AFTER SHAVES ist eine Reihe von hypoallergenen, dermatologisch getesteten, alkoholfreien Aftershave-Lotionen in kleinen Packungen, die sorgfältig gemischt werden, um ein hervorragendes Ergebnis bei der Hautpflege und Rasur für Männer zu erzielen. Hochwertige, 100% natürliche Inhaltsstoffe, die mit reinen und erfrischenden Noten in jedem ihrer Aromen begeistern.

### Vorteile:

- Bietet hervorragende Hydratation und Ernährung für Haut und Haarfollikel ohne Chemikalien
- Reduziert Juckreiz und trockene Haut
- Reduziert Hautreizungen und -rötungen erheblich
- Enthält keinen Alkohol
- Hypoallergenes Produkt
- Reduziert das Auftreten von Akne

*The Shaving Co. AFTER SHAVES è una serie di lozioni dopobarba ipoallergeniche, dermatologicamente testate e prive di alcool in piccoli flaconi, accuratamente miscelate per un risultato superiore nella cura della pelle e della rasatura maschile. Ingredienti premium naturali al 100% che deliziano con note pure e rinfrescanti in ciascuno dei loro aromi.*

### Benefici:

- Offre idratazione e nutrizione superiori alla pelle e ai follicoli piliferi senza agenti chimici
- Riduce la sensazione di prurito e secchezza sulla pelle
- Riduce notevolmente irritazioni e arrossamenti della pelle
- Non contiene alcool
- Prodotto ipoallergenico
- Diminuisce la comparsa dell'acne

- Sandelholz
- Sandalo

100 ml

REF.06376



- Zitrusfrüchte
- Citrus

100 ml

REF.06377



- Agrumi
- Lavender

100 ml

REF.06378





- 1888
- 1888

100 ml

REF.06379



### Bart Balsam Cera da barba

u.m.vta: 1  24 

60 ml

#### Citrus

REF. 04488



#### Wilderness

REF. 04490





#### Woodland

REF. 04489



### Bart-Öl Olio da barba

u.m.vta: 1  24 

30 ml

#### Woodland

REF. 04486

#### Wilderness

REF. 04487





Mr. Bear Family Beard Balm ist perfekt für den täglichen Gebrauch. Es befeuchtet ihn und macht ihn üppiger, weicher und schmeichelhafter. Nur mit Naturprodukten erstellt. Es ist ein hartes Wachs und muss vor der Anwendung erhitzt werden, indem es in der Tasche aufbewahrt, mit den Fingern gerieben oder mit dem Föhn kurz erhitzt wird.

Cera da barba Mr. Bear Family è perfetto per l'uso quotidiano. Idrata la barba rendendola più esuberante, morbida e gustosa al tatto. Formulato solo con prodotti naturali. È una cera dura e va riscaldata prima dell'applicazione, tenendola in tasca, sfregando con le dita o con un asciugacapelli.

Mr. Bear Family Bartöl ist nur mit natürlichen Ölen hergestellt. Macht den Bart weich und lässt ihn schmeichelhaft und nährt die Haut. Hilft, Rötungen und Reizungen zu verhindern. Befeuchtet den Bart und macht ihn weich, üppig und leicht kämmbar.

Olio da barba Mr. Bear Family realizzato solo con oli naturali. Ammorbidisce e lascia la barba gestibile nutrendo anche la pelle. Aiuta a prevenire arrossamenti e irritazioni. Idrata la barba lasciandola morbida, esuberante e facile da modellare.



### Schnurrbart-balsam Cera per baffi

u.m.vta: 1  24 

REF. 04493

#### Wilderness

30 ml

u.m.vta: 1  24 

REF. 04492

#### Citrus

30 ml





Mr. Bear Family Schnurrbartbalsam zum Verschönern und Formen des Schnurrbarts Hartwachs, das gut fixiert und den Schnurrbart in der gewünschten Form belässt. Das Wachs ist handgemacht und verwendet nur natürliche Inhaltsstoffe. Mit Karitébutter, Bienenwachs und ätherischen Ölen.

Cera per baffi Mr. Bear Family per abbellire e modellare i baffi. Cera dura che fissa bene e lascia i baffi nella forma desiderata. La cera è realizzata a mano, utilizzando solo ingredienti naturali. Con burro di karité, cera d'api e oli essenziali.



## Rasieröl Olio da barba

u.m.vta: 1  24 

30 ml



REF. 04495

Mr. Bear Family Rasieröl für eine angenehme Rasur. Hergestellt aus natürlichen Ölen. Dank seiner hohen Dichte wird es nicht von der Haut absorbiert. Es macht den Bart weicher, was die Rasur erleichtert, und fungiert als Schutzschild für die Haut während und nach der Rasur. Dadurch gleitet die Klinge weicher über die Haut. Es hilft auch, Rötungen, Irritationen, Juckreiz und Trockenheit der Haut nach der Rasur zu lindern.

*Olio da barba Mr. Bear Family per una piacevole esperienza di rasatura. A base di oli naturali. Ammorbidisce la barba, facilitando la rasatura e fungendo da scudo protettivo per la pelle durante e dopo la rasatura. Tutto ciò fa sì che la lama scivoli più dolcemente sulla pelle. Aiuta anche ad alleviare arrossamenti, irritazioni, prurito e secchezza della pelle dopo la rasatura.*



## Lippenbalsam Crema per labbra

u.m.vta: 1  48 

15 ml

**Pink grape**  
REF. 04496



15 ml

**Coco**  
REF. 04498



15 ml

**Mint**  
REF. 04497



Weiche, geschützte Lippen. 100% natürlich und handgefertigt. Mit angenehmen Aromen von rosa Trauben, Minze und Kokosnuss. Nährt, schützt und macht die Lippen von der ersten Anwendung an geschmeidig. Mit Kokosnussöl, Jojoba, Karitébutter, Carnaubawachs und ätherischen Ölen.

Labbra morbide e protette. 100% naturale e fatto a mano. Con piacevoli aromi di uva rosa, menta e cocco. Nutre, protegge e ammorbidisce le labbra fin dalla prima applicazione. Con olio di cocco, jojoba, burro di karité, cera di carnauba e oli essenziali.



### 100% natürlicher Alaunstein Pietra di allume naturale al 100%

u.m.vta: 1  378

75 g

REF.04220



Hand geschnitten, um Haut und Irritationen nach der Rasur zu beruhigen

*Tagliata a mano, per lenire la pelle e le irritazioni dopo la rasatura*

### Rasierseife mit Alaun Sapone da barba con allume

u.m.vta: 1  24

100 g

REF.04219



Rasierseife mit Alaun. Seine einzigartige Formel, die zu 100% auf Alaunstein und Karitébutter basiert, bereitet den Bereich für den Durchgang der Klinge vor und macht die Rasur zu einem sehr angenehmen Ritual.

*Sapone da barba con allume. La sua formula unica al 100% a base di pietra di allume e burro di karité prepara la pelle per il rasoio e rende la rasatura un rituale molto piacevole.*

### Blutstiller Stift Stick emostatico

u.m.vta: 12  1440

12 g

REF.04218



Schüttwar  
Sfusi  
REF.04218/01

Blutstillender Stift zur Behandlung von Mikroschnitten bei der Rasur. Hergestellt aus Kalium-Alaun. CE-zertifiziert. Externer und persönlicher Gebrauch. Wird in einer praktischen und sicheren Röhrrchen geliefert

*Stick emostatico per il trattamento dei micro tagli della rasatura. Realizzato con allume di potassio. Certificato CE. Uso esterno e personale. In un tubetto pratico e sicuro.*

### Rasier Set Kit da barba

u.m.vta: 1  1

REF.04221



Bestehend aus:

- Holzkasten
- Blutstillender Stift 12 gr
- Für die Reise, um die Benutzung zu erleichtern.
- Rasierseife mit Alaun
- Alaunstein 75 gr
- Hölzerne Bürste

Composto da:

- Cofanetto di legno
- Stick emostatico 12 gr
- da viaggio per facilitarne l'uso.
- Sapone da barba con allume
- Pietra di allume 75 gr
- Pennello in legno

## MYRSOL



### Zitronen Rasierwasser regeneriert die natürliche Hautschicht

*Lozione per massaggi all'acqua al limone che rigenera lo strato naturale della pelle*

u.m.vta: 1  8

180 ml

REF.03866

Regenerator des natürlichen Säureschutzmantels der Epidermis der Haut. Im Allgemeinen ist Zitronensäure wirksam gegen Pickel und verstärkte Talgbildung und macht die Haut weicher. Für die tägliche Rasur ohne Schmerzen und lindert sofort den auftretenden Juckreiz. Schließendes Tonikum. Er erzeugt ein außergewöhnliches Gefühl der Frische und hat ein angenehmes Aroma. Empfohlen für fettige Haut. Hydroalkoholische Lösung.

*Rigeneratore dello strato acido naturale della pelle, ed epidermide cutanea in generale, l'acido limone è efficace contro le macchie e la seborrea facciale e AMMORBIDISCE la pelle. Per radersi quotidianamente senza dolore. Astringente Tonico. Produce una straordinaria sensazione di fresco ed ha un aroma gradevole. Consigliato per la pelle grassa. Soluzione idroalcolica.*

200 ml

REF.04352



200 ml



180 ml



### Rasierwasser vor und nach der Rasur

*Lozione per massaggi Antesol prima e dopo la rasatura*

u.m.vta: 1  8

200 ml

REF.04650

Myrsol-Rasierwasser vor der Rasur und nach der Rasur. Fördert die Regeneration geschädigter Hautzellen und reduziert das Schmerzempfinden. Indiziert zur Behandlung trockener Haut als Feuchtigkeitsspender. Das Ergebnis ist eine glattere und gesündere Haut. Empfohlen für trockene Haut. Hydroalkoholische Lösung.

*Lozione per massaggi Myrsol Antesol prima e dopo la rasatura. Favorisce la rigenerazione delle cellule cutanee danneggiate e riduce la sensazione di dolore. Indicato per trattare le pelli secche come idratante. Il risultato è una pelle più liscia e sana. Consigliato per pelli secche. Soluzione idroalcolica.*

180 ml

REF.03867

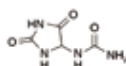

Allantoin  
Allantoina

200 ml



180 ml



## Aftershave Formel K Tonikum. Erfrischendes Menthol

### Tonico dopobarba Formula K. Menta rinfrescante

u.m.vta: 1 8

200 ml

REF.04643

After Shave Formel K. Seine erfrischende und tonisierende Wirkung hilft, Schmerzen und Irritationen zu lindern. Ganz gleich, wie empfindlich Ihre Haut ist, sie behält ihre natürliche Feuchtigkeit und Elastizität und beugt so der vorzeitigen Hautalterung vor. Empfohlen für trockene Haut. Hydroalkoholische Lösung

180 ml

REF.03872

*Dopobarba Formula K. La sua azione rinfrescante e tonificante aiuta a lenire dolori e irritazioni.*

*Non importa quanto sia delicata la tua pelle, il tonico dopobarba Formula K ne mantiene l'umidità e l'elasticità naturale, prevenendone l'invecchiamento precoce. Consigliato per pelli secche. Soluzione idroalcolica.*



## Balsamisches Rasierwasser zur Regeneration der Haut nach der Rasur

### Dopobarba rigenerante della pelle all'acqua balsamica

u.m.vta: 1 8

200 ml

REF.04642

Ausgezeichneter Hautregenerator. Beruhigung von Rasurreizungen. Es wird mit Substanzen hergestellt, die aus Rosmarin, Thymian, Lavendel und anderen Pflanzen extrahiert werden, die zur Abschwellung der durch Reiben, Quetschungen und nach der Rasur und Enthaarung angegriffenen Stellen angezeigt sind. Empfohlen für fettige Haut. Hydroalkoholische Lösung.

180 ml

REF.03875

*Ottimo rigeneratore della pelle. Calma l'irritazione dovuta alla rasatura. È realizzato con sostanze estratte da rosmarino, timo, lavanda e altre piante indicate per decongestionare le parti interessate da abrasioni, contusioni e dopo la rasatura e la depilazione. Consigliato per pelli grasse. Soluzione idroalcolica.*



## Alkoholfreie Rasieremulsion für die Massage vor und nach der Rasur

### Emulsione da barba senza alcool per massaggi prima e dopo la rasatura

u.m.vta: 1 8

200 ml

REF.04587

u.m.vta: 1 8

180 ml

REF.03869

u.m.vta: 1 16

75 ml

REF.04887

- Roll-on
- Roll-on



Anwendung: für eine schmerzfreie Rasur ohne Pinsel oder Seife und zur Massage vor und nach der Rasur. Für eine perfekte Rasur für den schwierigsten Bart und für die empfindlichste Haut. Ein Produkt mit überraschender Wirkung. Diese Emulsion ist extrem Feuchtigkeitsspendend, nährend, blutstillend und schmerzlindernd. Geeignet für Koteletten und Bartkonturen. Empfohlen für empfindliche Haut. Nicht-alkoholische Lösung.

Indicazioni: per una rasatura indolore senza pennello o schiuma e per il massaggio prima e dopo la rasatura. Per una rasatura perfetta delle barbe più difficili e per le pelli più delicate. Un prodotto dagli effetti sorprendenti. Questa emulsione è altamente idratante, nutriente, emostatica, analgesica. Indicato per basette e contorno barba. Consigliato per pelli sensibili. Soluzione non alcolica.

### Massage F./ Extra Lozione per massaggi F. extra

u.m.vta: 1  8

180 ml

**After shave**

REF.03877



Beruhigende Lozione für jede Art von Irritation, die durch die Rasur verursacht wird. Sie verleiht der Haut Glätte, Spannkraft und ein angenehmes Gefühl der Frische, mit heilender und beruhigender Wirkung.

*Lozione lenitiva per qualsiasi tipo di irritazione causata dalla rasatura. Dona alla pelle levigatezza, tono e una piacevole sensazione di freschezza con un effetto curativo e balsamico.*

### Aftershave Metilsol Lozione per massaggi Metilsol

u.m.vta: 1  8

180 ml

REF.03878



Es hat heilende und schliessende Eigenschaften und gleicht die Funktion der Talgdrüsen aus, indem es das Auftreten von Pickeln auf der Haut verhindert. Es hilft, Hautirritationen und Infektionen vorzubeugen. Blutstillend wirksam gegen Mikroschnitte bei der Rasur.

Ha proprietà cicatrizzanti e astringenti e riequilibra la funzione delle ghiandole sebacee, prevenendo la comparsa dei brufoli sulla pelle. Aiuta a prevenire le irritazioni e le infezioni della pelle. Emostatica ed efficace contro i micro-tagli.

### Gesichtstonikum Formel C Tónico per il viso Formula C

u.m.vta: 1  8

180 ml

REF.03874



Geeignet für die Hautpflege, insbesondere für fettige Haut. Regeneriert die Epidermis, erfrischt und repariert die Haut nach der Rasur. Feuchtigkeitsspendend, entspannend und beruhigend empfohlen für fettige Haut. Hydroalkoholische Lösung.

*Indicato per la cura della pelle, in particolare quelle grasse. Rigenera l'epidermide, rinfresca e ripara la pelle dopo la rasatura. Idratante, rilassante e lenitivo indicato per pelli grasse. Soluzione idroalcolica.*

### Rasierwasser Plastic Shave Lozione per massaggi Plastic Shave

u.m.vta: 1  8

180 ml

REF.03871



Um eine tägliche Rasur ohne Schmerzen und Beschwerden zu erreichen. Auch sehr geeignet zur Neutralisierung von Mückenstichen und anderen Insekten. Verbessert die Hauttextur und den Hutton sowie das allgemeine Erscheinungsbild, empfohlen für empfindliche Haut. Hydroalkoholische Lösung.

*Per una rasatura quotidiana piacevole e indolore. Molto adatta anche per neutralizzare punture di zanzara e altri insetti. Migliora la consistenza e il tono della pelle e l'aspetto in generale. Consigliata per pelli sensibili. Soluzione idroalcolica.*



## Rasierwasser Electric Lozione per massaggi Electric

u.m.vta: 1  8

180 ml

REF.03868



Lotion zum einölen der Haut und der elektrischen Maschine vor der Rasur. Lässt das Gerät besser gleiten, um Reibung und Hautreizungen zu verringern. Alkohollösung.

*Lozione indicata per lubrificare la pelle e il rasoio elettrico prima della rasatura. Facilita lo scorrimento del rasoio per ridurre l'attrito e l'irritazione della pelle. Soluzione non alcolica.*

## Aftershave Blue Lozione per massaggi Blue

u.m.vta: 1  8

180 ml

REF.03873



Myrsol-After Shave Blue. Die perfekte Ergänzung nach dem Rasieren wegen seiner tonisierenden und beruhigenden Eigenschaften. Hervorragend geeignet für Hauterkrankungen: Entzündungen, Irritationen, Austrocknung. Verleiht Frische, Spannkraft, Vitalität. Es hat einen unverwechselbaren Duft, der bei Hautkontakt anhält und für trockene Haut empfohlen wird. Hydroalkoholische Lösung.

*Myrsol-After shave Blue. Il perfetto complemento dopobarba per le sue proprietà toniche e lenitive. Ottimo per le seguenti condizioni della pelle: infiammazioni, irritazioni, disidratazione. Dona freschezza, tonicità, vitalità. Ha un profumo caratteristico che dura a contatto con la pelle. Consigliata per pelli secche. Soluzione idroalcolica.*

## Vitalisierendes Haarwasser Lozione vitalizzante per capelli

u.m.vta: 1  6

235 ml

REF.04644



- Kopfhautregenerator, Anti-Schuppen und Anti-Talg
- OHNE KLARSPÜLEN

- *Rigenerante del cuoio capelluto, antiforfora e anti-seborroica*
- SENZA RISCIAQUO

u.m.vta: 1  12

1000 ml

REF.06242

u.m.vta: 1  8

200 ml

REF.03876



- Flüssige Rasierseife mit Pinsel
- Sapone liquido per la rasatura a pennello

## Blutstillende Streichhölzer 20 Stück

### Emostatico in fiammiferi 20 servizi

THE  
LEGENDS

u.m.vta: 1  16

REF.06194

- Box mit 50 Streichholzbriefchen. 20 blutstillende Streichhölzer
  - 100% natürliche, leicht anzuwendende, zu transportieren und antiseptische Formel
  - Präsentationsbox nach Einheiten
  - 50 Streichholzbriefchen pro Schachtel
  - 20 Streichhölzer in jedem Briefchen
  - 300 gr
  - Hergestellt in PRC
- *Espositore 50 pacchetti 20 servizi di emostatico a fiammifero*
  - *Formula 100% naturale, facile da usare, da trasportare e antisetica*
  - *Scatola di presentazione per unità*
  - *50 pacchetti per scatola*
  - *20 fiammiferi in ogni pacchetto*
  - *300 gr*
  - *In PRC*



## Pomade THE LEGENDS

### Pomata THE LEGENDS

u.m.vta: 1  12

120 ml

REF.06195



## Gel THE LEGENDS

### Gel THE LEGENDS

u.m.vta: 1  12

220 ml

REF.06197



Leicht anzubringen, um zu gestalten und wieder zu entfernen, starker Halt

- Starker Halt - für den ganzen Tag
- Sauberer, milder Geruch
- Weiche Konsistenz
- Helle Farbe
- Mittlere Helligkeit
- Für alle Stile geeignet
- Einfach anzuwenden
- Weiße Plastikdose
- Vintage-Stil
- 120 ml / 4 oz
- In der EU hergestellt

Facile da applicare, rimodellare e rimuovere, tenuta forte

- *Tenuta forte - per tutto il giorno*
- *Odore delicato e pulito*
- *Consistenza leggera*
- *Colore chiaro*
- *Luminosità media*
- *Adatto a tutti i tipi di stili*
- *Facile da applicare*
- *Barattolo di plastica bianco*
- *Stile vintage*
- *4 once / 120 ml*
- *Made in UE*

Produkt der "alten Schule" mit starker Fixierung, nährend, restyling.

- Starker Halt - den ganzen Tag lang
- Parfüm
- Geschmeidige Konsistenz
- Halbtransparente rote Farbe
- Mittlerer Glanz auf nassem Haar
- Halbmatte auf trockenem Haar
- Alle Arten von Stilen
- Weiße Plastikdose
- Vintage-Stil
- 220 ml / 4 Unzen
- Produziert in der EU

Prodotto "old school" con tenuta forte, nutriente e restyling.

- *Tenuta forte - per tutto il giorno*
- *Fragranza*
- *Consistenza delicata*
- *Colore rosso semitrasparente*
- *Lucentezza media sui capelli bagnati*
- *Finitura opaca media su capelli asciutti*
- *Tutti i tipi di stili*
- *Barattolo di plastica bianco*
- *Stile vintage*
- *4 once / 220 ml*
- *Made in UE*

## Anti-Haarausfall Shampoo

### Shampoo anti caduta

**TASSEL**  
PROFESSIONAL HAIR COSMETICS

u.m.vta: 1  12

1000 ml

REF.03566

- Shampoo, das speziell zur Bekämpfung von Haarausfall erstellt wurde, da es Proteine und Bionährstoffe pflanzlichen Ursprungs kombiniert, die als abschwellende und revitalisierende Mittel wirken und Reizungen verhindern
- Reinigt tief, entfernt die sich auf der Kopfhaut bildenden Öle und lässt das neue Haar ungehindert wachsen.
- Das Haar wird weich, glänzend und seidig

u.m.vta: 1  6

400 ml

REF.03555

- *Shampoo specificamente formulato per combattere la caduta dei capelli, in quanto combina proteine e bionutrienti di origine vegetale che agiscono come decongestionanti e rivitalizzanti, evitando così le irritazioni.*
- *Deterge in profondità, eliminando i grassi che si formano sul cuoio capelluto, permettendo così ai nuovi capelli di crescere senza impedimenti*
- *Capelli morbidi, lucenti e setosi*



## Ampullen gegen Haarausfall

### Fiale anti caduta

u.m.vta: 1  6

REF.03550

- 12 Ampullen zur Vorbeugung von Haarausfall
- Präventionsshampoo 400 ml
- 12 Fiale anti caduta
- Shampoo prevenzione anti caduta 400 ml



u.m.vta: 1  6

REF.03551

- 12 Ampullen zur Vorbeugung von Haarausfall
- 10 ml pro Ampulle
- 12 Fiale anti caduta
- 10 ml ogni fiala





Die besten Nährstoffe für die Kopfhaut sind Proteine pflanzlichen Ursprungs. Sie verbessern die Aufnahme derselben und begünstigen die Sauerstoffanreicherung des Haarfollikels, wodurch der Haarausfall verringert wird. Die pflanzlichen Nährstoffe wirken auch als abschwellende und revitalisierende Mittel, um Reizungen zu vermeiden. Keratin repariert und stärkt das Haar und verleiht ihm Volumen und Glanz.

*I migliori nutrienti per il cuoio capelluto sono le proteine vegetali. Queste fiale ne aumentano l'assorbimento e favoriscono l'ossigenazione del follicolo pilifero, riducendo così la caduta dei capelli. I nutrienti vegetali agiscono anche come decongestionanti e rivitalizzanti, evitando così le irritazioni. La cheratina ripara e rinforza i capelli, donandogli volume e lucentezza.*

## Haarfasern

### Polvere di fibre

u.m.vta: 1  6 

- Mit Dosiermöglichkeit
- Für Männer und Frauen. Ideal bei Haardichteverlust. Tarnung von Bereichen mit wenig Haar schnell und natürlich
- Haftet am Haar und verleiht ihm mehr Volumen und Dicke
- Einfaches Auftragen durch Schütteln des Glases über die Applikationsfläche
- Erhältlich in 6 Farben: schwarz, dunkelbraun, mittelbraun, hellbraun, dunkelblond und hellgrau passend zur natürlichen Haarfarbe

- Con dosatore
- Per uomini e donne. Ideale contro la perdita di densità capillare. Nasconde le aree assottigliate in modo rapido e naturale
- Aderisce ai capelli donando loro maggior volume e spessore
- Si applica facilmente agitando il barattolo sull'area di applicazione
- Disponibile in 6 colori: nero, castano scuro, castano medio, castano chiaro, biondo scuro e grigio chiaro che si adattano al tono del colore naturale dei capelli

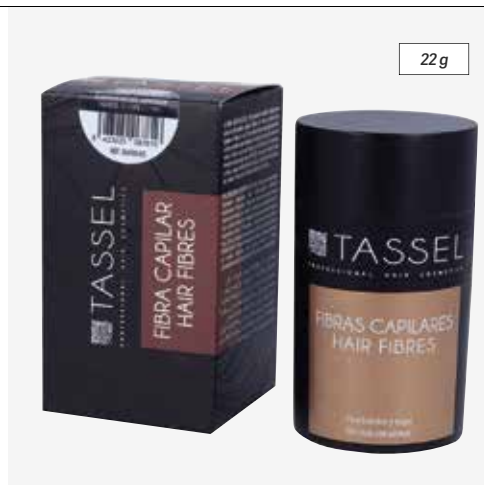

Schwarz · Nero  
REF.06436/50

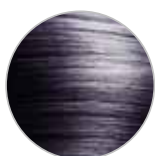

Hellgrau · Grigio chiaro  
REF.06436/72

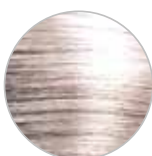

Dunkelblond · Biondo scuro  
REF.06436/66

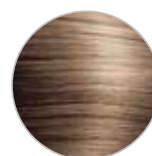

Dunkelbraun · Castano scuro  
REF.06436/67



Mittelbraun · Castone medio  
REF.06436/76

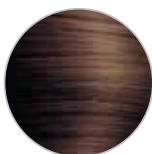



Hellbraun · Castone medio  
REF.06436/65



## Fixier-Zerstäuber

### Atomizzatore per fibra capillare

u.m.vta: 1  12 

REF.07208



- Benutzerfreundlich
- Ermöglicht eine gleichmäßigere Verteilung der Haarfasern an bestimmten Stellen.
- Ermöglicht, dass die Fasern viel leichter an Ihrem natürlichen Haar anhaften. Es wird eine geringere Menge des Produkts benötigt, um den gewünschten Look zu erzielen.
- Leicht zu lagern

- Facile da usare
- Consente una distribuzione più uniforme delle fibre capillari in zone specifiche.
- Permette alle fibre di aderire ai tuoi capelli naturali molto più facilmente. È necessario meno prodotto per ottenere l'aspetto desiderato.
- Facile da riporre

#### VERWENDUNG:



Geben Sie die Haarfasern in die Glasflasche und bringen Sie den Zerstäuber an, um sie zu pulverisieren. Drücken Sie hierfür die Pumpe nach oben und nach unten.

#### COME USARE:

Versare le fibre dei capelli nella bottiglia di vetro e sistemare l'atomizzatore per nebulizzarle. Premere la pompetta a tale scopo.

## Haarfaser-Lack

### Lacca per fibra capillare

u.m.vta: 1  30 

100 ml

REF.06649

Für maximale Fixierung und Unterstützung der Fasern

*Per una massima fissazione e tenuta delle fibre*



## Verkaufsträger haarfasern (als geschenk)

### Espositore per fibre capillari

u.m.vta: 1  1

REF.07801

- Umfasst 6 Farbtöne für haarfasern + fixierlack
- Ref. 06436/50 Schwarz 22 g
- Ref. 06436/72 Hellgrau 22 g
- Ref. 06436/66 Dunkelblond 22 g
- Ref. 06436/67 Dunkelbraun 22 g
- Ref. 06436/76 Mittelbraun 22 g
- Ref. 06436/65 Hellbraun 22 g
- Ref. 06649 Fixierlack haarfasern 100 ml.

- Include 6 tonalità di fibra capillare + lacca fissante
- Rif. 06436/50 Nero 22g.
- Rif. 06436/72 Grigio chiaro 22g.
- Rif. 06436/66 Biondo scuro 22g.
- Rif. 06436/67 Castano scuro 22g.
- Rif. 06436/76 Castano medio 22g.
- Rif. 06436/65 Castano chiaro 22g.
- Rif. 06649 Lacca fissante fibre capillari 100 ml.



## Wachs-Roll-on Mann

### Roll-on cera uomo

u.m.vta: 24  24

100 ml

REF.03858

Das Roll-on-Haarentfernungssystem ist optimal für diejenigen Fachleute, die die besten Ergebnisse erzielen möchten. Die Harze, mit denen wir die Wachse herstellen, können bei einer höheren Temperatur als niedrig schmelzende Wachse verwendet werden, mit dem Vorteil, dass sie mit einem dünneren Streifen aufgetragen werden. Auf diese Weise kühlt das Wachs fast augenblicklich ab und das Wärmeempfinden auf der Haut wird minimiert. Das Wachs lässt sich mit den Hygienestreifen leicht entfernen. Kombinierte Staffelpreise Seite 556-557-558

*Il sistema di depilazione roll-on è ottimale per quei professionisti che cercano di ottenere i migliori risultati. Le resine con le quali produciamo le cere possono essere utilizzate ad una temperatura più elevata rispetto alle cere a basso punto di fusione, con il vantaggio di essere applicate mediante una striscia più sottile. Così, la cera si raffredda quasi istantaneamente e la sensazione di calore sulla pelle è ridotta al minimo. La cera si rimuove facilmente con le salviette igieniche. Prezzi scalati combinabili pagina 556-557-558*



07

## Möbel und dekoration Complementi d'arredo



*Barberpole, Barbierstuhl, Waschbecken,  
Kinderstühle, Spiegel und Arbeitswagen...*

*Polo barber, poltrone barber, lavatesta, specchi,  
trolleys & poltrone per bambini.*



## Barberpole Barberpole Palo del barbiere

Con cable  
Con cavo

u.m.vta: 1  1 

### REF. 04745

- Leistung: 12W
- Schleuderdrehzahl: 50-60 U/MIN
- Vintage Barberpole-Laterne
- Mit Licht und Schwenkmöglichkeit
- Spannung: 220-240V~
- Frequenz: 50/60 Hz
- Potenza: 13W
- Velocità di rotazione: 50-60 RPM
- Polo barber nero luminoso e rotante Ø 20 cm
- Luce e rotazione opzionali
- Voltaggio: 220-240V~
- Frequenza: 50/60 Hz

### REF. 04578

- Leistung: 13W
- Schleuderdrehzahl: 50-60 U/MIN
- Leuchtende schwarze rotierende Barberpole Ø 20 cm
- Mit Licht und Schwenkmöglichkeit
- Spannung: 220-240V~
- Frequenz: 50/60 Hz
- Potenza: 13W
- Velocità di rotazione: 50-60 RPM
- Polo barber nero luminoso e rotante Ø 20 cm
- Luce e rotazione opzionali
- Voltaggio: 220-240V~
- Frequenza: 50/60 Hz

### REF. 04744

- Leistung: 13W
- Schleuderdrehzahl: 50-60 U/MIN
- Verchromte Barberpolemit Leuchtzifferblatt
- Mit Licht und Schwenkmöglichkeit
- Spannung: 220-240V~
- Frequenz: 50/60 Hz
- Potenza: 13W.
- Velocità di rotazione: 50-60 RPM
- Cromato con quadrante luminoso
- Luce e rotazione opzionali
- Voltaggio: 220-240V~
- Frequenza: 50/60 Hz

### REF. 04743

- Leistung: 13W
- Schleuderdrehzahl: 50-60 U/MIN
- Große verchromte Barberpole
- Mit Licht und Schwenkmöglichkeit
- Spannung: 220-240V~
- Frequenz: 50/60 Hz
- Potenza: 13W.
- Velocità di rotazione: 50-60 RPM
- Cromato grande
- Luce e rotazione opzionali
- Voltaggio: 220-240V~
- Frequenza: 50/60 Hz

### REF. 04946

- Leistung: 17W
- Schleuderdrehzahl: 50-60 U/MIN
- Kleine verchromte Barberpole
- Mit Licht und Schwenkmöglichkeit
- Spannung: 220-240V~
- Frequenz: 50/60 Hz
- Potenza: 17W.
- Velocità di rotazione: 50-60 RPM
- Piccolo cromato
- Luce e rotazione opzionali
- Voltaggio: 220-240V~
- Frequenza: 50/60 Hz



Der Ursprung der rot-weißen Barbierstange geht auf das Mittelalter zurück, als die Barbieri neben der Zahnextraktion auch Operationen an ihren Kunden vornahm. Der Pfosten hatte ursprünglich oben eine Bronzeschale, die das Gefäß darstellte, in dem sie die Blutegel aufbewahrten, und unten eine weitere, in Anspielung auf das Gefäß, das das Blut aufnahm. Die Stange selbst symbolisiert den Stab oder Stock, den der Patient während des Eingriffs hielt, um den Blutfluss zu erleichtern. Aus diesem Grund wird der Barbierstab mit den angebotenen Dienstleistungen, einschließlich des Aderlasses, in Verbindung gebracht. In der Vergangenheit wurde sie durch blutige Verbände dargestellt, die um einen Pfahl gewickelt waren.

L'origine del polo barber rosso e bianco risale al Medioevo, quando i barbieri eseguivano anche interventi chirurgici per i loro clienti, nonché estrazioni dentali. Il polo aveva originariamente una bacinella di bronzo nella parte superiore rappresentante il contenitore dove venivano conservate le sanguisughe e un'altra nella parte inferiore alludente al contenitore per il sangue estratto. Il polo stesso simboleggia il palo o il bastone che il paziente afferrava durante la procedura per facilitare il flusso di sangue. Ecco perché il polo barber è associato ai servizi offerti, compresi i salassi. Storicamente era formato da bende insanguinate avvolte attorno a un palo.

## Barbierstuhl SPRINGFIELD

### Poltrona barber SPRINGFIELD

u.m.vta: 1  1

REF.06955



SCAN  
ME!

Der neue Springfield Barbierstuhl wurde in einem modernen Stil entworfen, ohne jedoch seine Funktionalität und klassischen Linien zu verlieren. Der Sessel verfügt über eine Hydraulikpumpe, mit der wir den Sitz heben und senken können, so dass wir unseren Kunden auf die Höhe bringen können, die für unsere Arbeit am besten geeignet ist. Der Schaumstoff der Rückenlehne hat eine Dicke von 6 cm und des Sitzes von 11 cm, dadurch passt sich unser Kunde gut an den Sessel an und ist sehr bequem. Die Kopfstütze ist abnehmbar und verstellbar, so dass wir sie an jede Arbeit anpassen können. Die Rückenlehne des Stuhls kann um 108 Grad gekippt werden. Gleichzeitig mit der Neigung der Rückenlehne wird auch die Fußstützenstruktur gekippt, um maximalen Komfort zu gewährleisten.

La nuova poltrona da barbiere Springfield è progettata con uno stile moderno ma senza perdere la sua funzionalità e le sue linee classiche. La poltrona è composta da una pompa a gas che permette di alzare e abbassare la seduta, in modo da poter posizionare il cliente all'altezza più adatta per il nostro lavoro. La gommapiuma dello schienale ha uno spessore di 6 cm e il sedile di 11 cm, questo farà sì che il nostro cliente si adatti bene alla poltrona e si senta completamente a suo agio. Il poggiatesta è removibile e regolabile, in questo modo possiamo adattarlo ad ogni esigenza. Lo schienale della sedia può essere inclinato di 108 gradi, contemporaneamente, mentre incliniamo lo schienale, anche la struttura del poggiatesta si inclinerà per offrire il massimo comfort.

## Barbierstuhl STAFFORD

### Poltrona barber STAFFORD

u.m.vta: 1  1 

REF.06956/50



REF.06956/50

SCAN  
ME!

Der neue Stafford-Barbierstuhl wurde mit Retro-Style entworfen. Er gilt als "Vintage"-Sessel, da er Stahl und Stoff mit einem abgenutzten Effekt vermischt. Mit der Qualität der neuesten Generation ist er mit einer Hydraulikpumpe zur Regulierung der Sitzhöhe ausgestattet. Die Fußstütze ist drehbar und die Rückenlehne ist neigbar. Die Kopfstütze ist abnehmbar und auch verstellbar, um sie an jeden Arbeitsplatz anzupassen. Erhältlich in Schwarz und Braun. Neigung von etwa 120 Grad.

La nuova poltrona da barbiere Stafford è progettata con linee e finiture retró. Viene considerata una poltrona "vintage" in quanto combina acciaio e tessuto per ottenere un effetto consumato. Di qualità all'avanguardia, è dotata di una pompa a gas per regolare l'altezza della seduta. Il poggiatesta è girevole e lo schienale è reclinabile. Il poggiatesta è removibile e anche regolabile per poterlo così adattare ad ogni esigenza. Disponibile nei colori nero e marrone. Inclinazione di circa 120 gradi.



## Barbierstuhl VIGOR

### Poltrona barber VIGOR

u.m.vta: 1  1

REF.04888

REF.04888/73



SCAN  
ME!

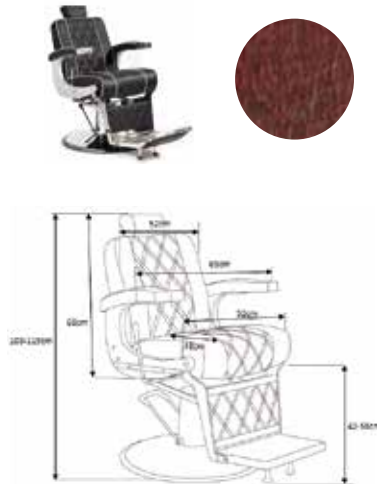

Der Barbierstuhl VIGOR ist in einem modernen Stil entworfen, ohne jedoch seine Funktionalität und seine klassischen Linien zu verlieren. Der Sessel verfügt über eine Hydraulikpumpe, die es ermöglicht, den Sitz zu heben und zu senken, so dass unser Kunde in der Höhe platziert werden kann, die der Arbeit am besten entspricht. Der Schaumstoff der Rückenlehne ist 13,5 cm und der Schaumstoff des Sitzes 11,5 cm dick, so dass sich der Klient gut an den Sessel anpassen und sehr bequem sitzen kann. Die Kopfstütze ist abnehmbar und verstellbar, so dass sie an jeden Arbeitsplatz angepasst werden kann. Die Rückenlehne des Stuhls kann um 130 Grad gekippt werden, während gleichzeitig die Rückenlehne gekippt wird. Die Struktur der Fußstütze wird sich für maximalen Komfort ebenfalls neigen.

*La poltrona da barbiere VIGOR è progettata con uno stile moderno ma senza perdere la sua funzionalità e le sue linee classiche. La poltrona è composta da una pompa a gas che permette di alzare e abbassare la seduta, in modo da poter posizionare il cliente all'altezza più adatta per il nostro lavoro. La gommapiuma dello schienale ha uno spessore di 13,5 cm e il sedile di 11,5 cm, questo farà sì che il cliente si adatti bene alla poltrona e si senta completamente a suo agio. Il poggiatesta è removibile e regolabile, in questo modo è possibile adattarlo ad ogni esigenza. Lo schienale della sedia può essere inclinato di 130 gradi allo schienale. Mentre si inclina lo schienale, allo stesso tempo, anche la struttura del poggiatesta si inclinerà per offrire il massimo comfort.*



## Barbierstuhl CLASSIC

### Poltrona barber CLASSIC

u.m.vta: 1  1

●  
REF.06087/50

●  
REF.06087/73

●  
REF.06087/62



SCAN  
ME!

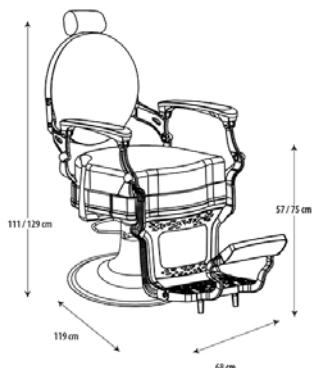

Der Barbierstuhl CLASSIC mit klassischen Linien und modernster Verarbeitung. Er ist mit einer Hydraulikpumpe zur Regulierung der Sitzhöhe ausgestattet. Die Fußstütze ist schwenkbar und die Rückenlehne ist verstellbar, um dem Kunden maximalen Komfort zu bieten. Der Schaumstoff der Rückenlehne ist 2,5 cm und der Sitz 7,5 cm dick, so dass sich der Kunde sehr wohl fühlen wird. Auch die Kopfstütze ist abnehmbar und verstellbar, so dass sie an jeden Arbeitsplatz angepasst werden kann. Erhältlich in drei Farben: schwarz, granat und grün.

La poltrona da barbiere CLASSIC si distingue per linee classiche e finiture di ultima generazione. È dotata di una pompa a gas per regolare l'altezza della seduta. Il poggiatesta è girevole e lo schienale è reclinabile per offrire il massimo comfort al cliente. La gommapiuma dello schienale ha uno spessore di 2,5 cm e il sedile di 7,5 cm, questo farà sì che il cliente si adatti bene alla poltrona e si senta completamente a suo agio. Anche il poggiatesta è removibile e anche regolabile per poterlo così adattare ad ogni esigenza. Disponibile in tre colori: nero, granata e verde.

## Hydraulischer Barbierstuhl MODERNIS

### Poltrona barber MODERNIS

u.m.vta: 1  1

REF. 03628

- Dreht sich um 360°.
- Breite von Arm zu Arm 57 cm
- Kopfstütze 19 x 13 cm
- Rückenlehne 51 x 41 cm
- Neigbar um 130°

- Ruota di 360°
- Larghezza da bracciolo a bracciolo: 57 cm
- Poggiatesta 19 x 13 cm
- Schienale 51 x 41 cm
- Reclinabile 130°



## Hydraul. Stuhl zur individuellen Gestaltung Poltrona barber, personalizzabile

u.m.vta: 1  1

REF.04508/01



### GESTALTE DEINEN BARBIERSTUHL

1. ENTSCHIEDEN SIE DIE FARBE DES SOCKELS
2. WÄHLEN SIE DIE FARBE DER POLSTERUNG



- Stuhlgestell: Aluminiumguss
- Die Chromteile sind aus Bronze und Eisen
- Die Struktur, auf der die Polsterung angebracht wird, besteht aus Kiefernholz.
- Zertifizierte Schaumstoffe und Beschichtungen
- Sockel mit lackiertem Polyester beschichtet (gleiches System wie bei Autos)

### PERSONALIZZA LA TUA POLTRONA

1. DECIDI IL COLORE DELLA BASE
2. SCEGLI IL COLORE DEL TUO SEDILE

- Struttura della sedia: lega di alluminio
- Le parti cromate sono in bronzo e ferro
- La struttura su cui poggia il rivestimento è in pino
- Imbottitura e rivestimenti certificati
- Base rivestita in poliester verniciato (stesso sistema delle auto)

## Neigbarer Stuhl Poltrona reclinabile

u.m.vta: 1  1 

REF. 02975/50

- Neigung 130° / Idraulica
- Breite von Arm zu Arm: 57 cm
- Breite der Kopfstütze: 19 cm
- Rückenlehne: 51 x 41 cm
- Kopfstützen Höhe: 13 cm
- Abstand zwischen Rückenlehne und Kopfstütze: 14 cm
- Gewicht: 32,5 kg
- Abnehmbarer Kopf mit einer Verstellung

- Reclinabile 130° / idraulica
- Larghezza da bracciolo a bracciolo: 57 cm
- Larghezza del poggiatesta della sedia: 19 cm
- Schienale: 51 x 41 cm
- Altezza del poggiatesta: 13 cm
- Distanza tra schienale e poggiatesta: 14 cm
- Peso: 32,5 kg
- Poggiatesta smontabile con una posizione



## Barbierstuhl TRADITIONAL Poltrona barber TRADITIONAL

u.m.vta: 1  1

REF.06089/50



SCAN  
ME!

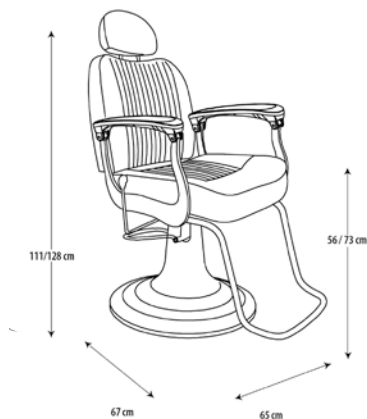

Der TRADITIONAL Barbierstuhl wurde als nüchterner und leicht zu handhabender Stuhl hergestellt, im Vintage Stil, ohne den Komfort zu vergessen. Er ist mit einer Hydraulikpumpe zur Regulierung der Sitzhöhe und einer verstellbaren Rückenlehne ausgestattet, um dem Kunden maximalen Komfort zu bieten. Der Schaumstoff des Rückens hat eine Dicke von 9 cm und des Sitzes von 10 cm, so dass sich der Kunde gut an den Sessel anpassen und sich sehr wohl fühlen kann. Die Kopfstütze ist abnehmbar und auf verschiedene Höhen einstellbar. Es hat auch eine bequeme Fußstütze.

La poltrona da barbiere TRADITIONAL è stata realizzata come una sedia sobria e maneggevole, con uno stile molto vintage, senza dimenticare il comfort. È dotata di una pompa a gas per regolare l'altezza della seduta e di uno schienale reclinabile per offrire il massimo comfort al cliente. La gommapiuma dello schienale ha uno spessore di 9 cm e il sedile di 10 cm, questo farà sì che il cliente si adatti bene alla poltrona e si senta completamente a suo agio. Il poggiatesta è rimovibile e regolabile a diverse altezze. Dispone inoltre di un comodo poggiatesta.

## Waschbecken TRADITIONAL

### Poltrona lavatesta TRADITIONAL

u.m.vta: 1	 1
------------	---

REF.06090/50

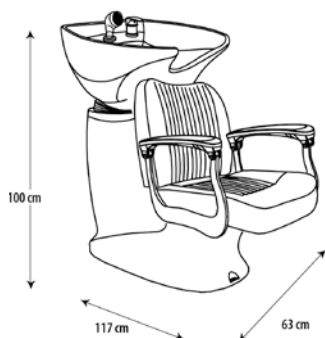

Das Waschbecken TRADITIONAL wurde in Anlehnung an den Stuhl TRADITIONAL (ref.06089/50) wurde als nüchternes und sehr altertümliches Waschbecken hergestellt, ohne dabei den Komfort zu vergessen. Vervollständigen Sie die Gestaltung Ihres Salons mit diesem Waschbecken!

*La poltrona lavatesta TRADITIONAL sulla linea della poltrona barber TRADITIONAL (rif. 06089/50) è stata realizzata come una lavatesta dallo stile sobrio e molto vintage, senza però dimenticare il comfort.*

*Completa il design del tuo salone con questo lavatesta!*

## Waschbecken STAFFORD

### Poltrona lavatesta STAFFORD

u.m.vta: 1	 1
------------	---



REF.06957/50



REF.06957/69

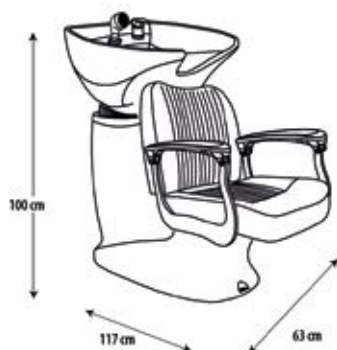



Das Waschbecken Stafford, das in der Linie des "Traditional" Barbierstuhls (ref.06089/50) designt ist, folgt ebenfalls der Ästhetik des "traditionellen" Waschbeckens, jedoch mit dem Unterschied, dass das Waschbecken Stafford es aus Stahl gefertigt und eine abgenutzte Oberfläche "vintage" auf dem Sitz hat.

*La poltrona lavatesta Stafford, seguendo la linea della poltrona da barbiere "tradizionale" (rif.06089/50) segue anche l'estetica della poltrona lavatesta "tradizionale" ma con la differenza che la poltrona lavatesta Stafford si caratterizza per essere realizzata in acciaio e con una finitura "vintage" sulla seduta.*

## Waschbecken STIL

### Poltrona lavatesta STIL

u.m.vta: 1  1 

\* Ersatzteile verfügbar  
\* Parti di ricambio disponibili

●  
REF. 02841

●  
REF. 02841/54

○  
REF. 02841/58



- Armlehnen und Bedienelemente aus Chrom
- Keramikbecken und Glasfasersockel
- Schiebesitz
- Sockellänge 76 cm
- Sitzbreite 48 cm
- Höhe der Rückenlehne 41 cm
- Keramikbecken 57 x 50 x 20 cm
- Gesamthöhe 95 cm

- Bracciali e rubinetto cromati
- Lavello in ceramica e base in fibra di vetro
- Sedile scorrevole
- Lunghezza base 76 cm
- Larghezza sedile 48 cm
- Altezza schienale 41 cm
- Lavello in ceramica 57 x 50 x 20 cm
- Altezza totale 95 cm

## Kinderstühle

### Poltrone per bambini

u.m.vta: 1  1

Hochwertige Kinderstühle, aus Metall und im Vintage-Stil das Kindern die Erfahrung des Friseurbesuchs angenehm machen soll. Tretautos, die funktionieren, wenn sie aus der Halterung entfernt werden. Dekorative Lichter und Sicherheitsgurt. Wenn Sie das Lenkrad drehen, bewegen sich auch die Vorderräder. Keine Hupe vorhanden.

*Poltrone per bambini di alta qualità, realizzate in metallo e con uno stile vintage per rendere piacevole l'esperienza di andare dal parrucchiere ai bambini. Auto a pedali che funzionano se rimosse dal piedistallo. Luci decorative e cintura di sicurezza. Inoltre, se si gira il volante, le ruote anteriori si muovono. Senza clacson.*



24 kg



REF.04728



26,8 kg



REF.04727



### Spezialstuhl für Kinder Poltrona speciale per bambini

u.m.vta: 1  1

REF.02733



### Kissen speziell für Kinder Cuscini speciali per bambini

u.m.vta: 1  2

REF.07329/50



### Kissen speziell für Kinder Cuscini speciali per bambini

u.m.vta: 1  1

REF.03939

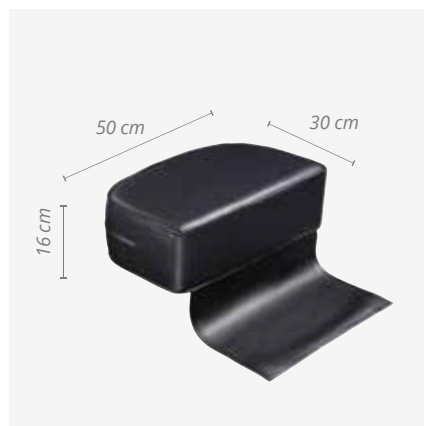

### Kissen speziell für Kinder Cuscini speciali per bambini

u.m.vta: 1  1

● REF.04506/50    ● REF.04506/60

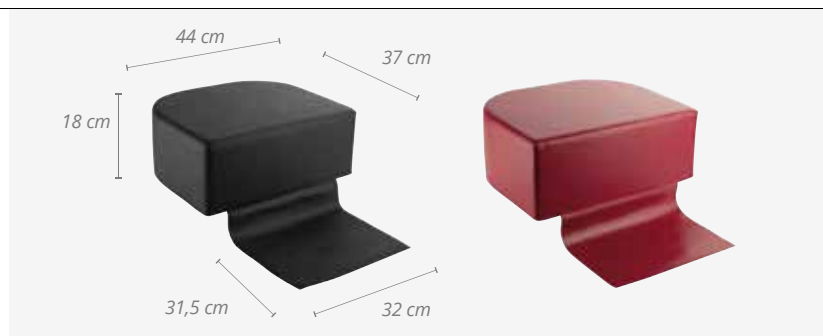

Spezielle Kissen, die für jeden Friseurstuhl geeignet sind. Sie ermöglichen dem Fachmann ein bequemerer Arbeiten, da sie das Kind auf die ideale Höhe bringen.

Cuscini speciali adatti a qualsiasi poltrona da parrucchiere. Consentono un lavoro più confortevole per il professionista, poiché sollevano il bambino all'altezza ideale.



## BARBER Wandspiegel Specchio da parete BARBER

u.m.vta: 1  1

REF.06091

Der Wandspiegel BARBER im Vintage-Stil ist funktionell und praktisch dank seines Regalsystems, das es Ihnen ermöglicht, die gewünschten Objekte abzustellen. Er verleiht Ihrem Salon einen "Old-School"-Touch!

*Lo specchio da parete BARBER, in stile vintage, è funzionale e pratico grazie alla sua mensola in quanto permette di appoggiare gli oggetti che si vuole. Dai un tocco "old school" al tuo salone!*



## Rustikaler Frisiertisch der Barber Line Specchio rustico con mensola Barber Line

u.m.vta: 1  1

REF.06670

Frisierkommode aus Polyurethanharz auf mdf-Basis, einem Material mit besseren Eigenschaften als Holz in Bezug auf Festigkeit und Stabilität. Sicherheitsgeprüft feuerfest, selbstlöschend und antibakteriell. Oberfläche in rustikalem Holz mit zwei Zierteilen, die schwarzes Eisen imitieren. Holzähnlicher Touch, perfekte Imitation.

*Specchio con mensola realizzato in resina poliuretanic a base di mdf, un materiale con proprietà migliori del legno in termini di resistenza e stabilità. Classificazione: ignifuga, autoestinguente e antibatterica. Finitura in legno rustico con due placche ornamentali che imitano il ferro in colore nero. Simile al legno al tatto, imitazione perfetta.*



**Arbeitswagen aus Holz/Metall TOD**  
**Carrello barber in legno e metallo TOD**

u.m.vta: 1  1



REF.04698/54



**Kapitän Cook Capta-Tonne**  
**Bidone Captain Cook**

u.m.vta: 1  1

REF.06054



**Empfangstheke aus Holz und Metall mit Spiegeleffekt**  
**Bancone reception in legno e metallo a effetto specchio**

u.m.vta: 1  1

REF.03935

Mit Innenfächern aus Holz zur Aufbewahrung und Ablage  
 Con scomparti interni in legno



**Sofa mit 3 Sitzplätzen**  
**Divano attesa 3 posti**

u.m.vta: 1  1

REF.03950



In Kunstleder  
 In similpelle

## Empfangstheke EARTH

### Banco reception EARTH

u.m.vta: 1  1

Graphit · Grafite

Weiß · Bianco

Eiche · Quercia



REF.04518/50

REF.04518/58

REF.04518/65

- Graphit-Laminat
- Mit verstellbaren Einlegeböden und 1 Schublade

- Laminato in grafite
- Con ripiani regolabili e 1 cassetto



## Rolle 100 Schutzbezüge für stuhl

### Rotolo 100 protezioni per poltrone

u.m.vta: 1  1

REF.07239

SCAN  
ME!

- Halten Sie Keime von Ihrem Sitzplatz fern. Schnelle und einfache Desinfektion in wenigen Sekunden. Entfernen Sie danach den Bezug von dem Sitz und entsorgen Sie ihn. Passt für die meisten Stühle mit Lehne.
- 65+16 x 150 cm / 0,025 mm

- *Mantieni i germi lontani. Disinfezione rapida e semplice: in pochi secondi rimuovi il rivestimento del sedile e lo smaltisci. Si adatta alla maggior parte delle poltrone con schienale.*
- 65+16 x 150 cm / 0,025 mm



### Handtuch-Container Porta asciugamani

u.m.vta: 1  4

REF.03159



- Mit Rädern
- Waschbarer Container-Beutel
- Struktur aus rostfreiem Stahl
- Con ruote
- Borsa contenitore lavabile
- Struttura in acciaio inox

### Handtuchhalter Organizer per appendere asciugamani

u.m.vta: 1  6

REF.04378

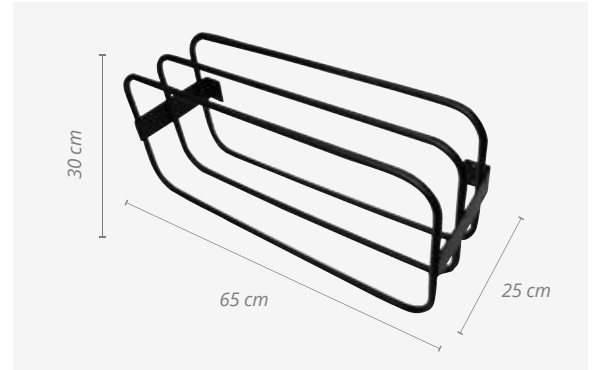

### Handbrause mit Anschluss Doccia con supporto

u.m.vta: 1  20

REF.03004



### Aufsatz Dusch-Set Set doccia adattabile

u.m.vta: 1  10

REF.01960



### Einhandmischer für Waschbecken Miscelatore per lavatesta

u.m.vta: 1  50

REF.02837



### Ionischer Duschkopf Soffione doccia ionico

u.m.vta: 1  36

REF.03750

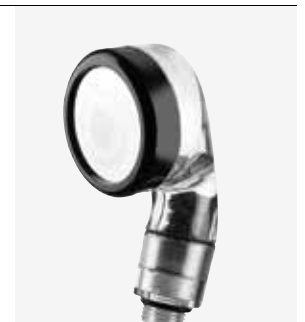

Spart Wasser Bessere  
Wasserqualität

Risparmio idrico Migliore  
qualità dell'acqua

**Einhebelmischer und Brause für Kopfwäsche**  
*Miscelatore monocomando e doccia per soffione*

u.m.vta: 1  12

REF.07618

**NEW**



**Dusche mit Waschkopfhalterung**  
*Doccia con supporto lavatesta*

u.m.vta: 1  12

REF.07619

**NEW**



**Verchromter Duschkopf**  
*Soffione doccia cromato*

u.m.vta: 1  12

REF.07620

**NEW**



**Schwarze Waschkopfbrause**  
*Soffione doccia nero*

u.m.vta: 1  12

REF.07625

**NEW**



**Kopfspülbeckenventil**  
*Valvola del lavello del lavaggio*

u.m.vta: 1  12

REF.07626

**NEW**



**Wasserdurchflussbegrenzer**  
*Riduttore di flusso d'acqua*

u.m.vta: 1  12

REF.07623

**NEW**



**Ablaufrohr für Kopfspülung bis 80 cm**  
*Tubo di scarico lavatesta fino a 80 cm*

u.m.vta: 1  12

REF.07624

**NEW**



**Flexibler PVC-Duschschlauch 120 cm für Waschbecken**  
*Tubo doccia flessibile in pvc 120 cm per lavabo*

u.m.vta: 1  12

REF.07621

**NEW**



**Flexibler Nylon-Duschschlauch für Kopfwascher**  
*Tubo doccia flessibile in nylon per lavatesta*

u.m.vta: 1  12

REF.07781

**NEW**





08

## Zubehör Accessori

*Schutzpapier, Barbershop-Kleidung,  
Sprühflaschen, Koffer, Hygiene...*

*Carta collo, abbigliamento da barbiere,  
spruzzini, valigie, igiene...*





Nackenpapier ist ein Klassiker im Friseurladen, um Juckreiz im Nacken und die Möglichkeit zu vermeiden, dass kleine Härchen in die Kleidung gelangen.

*La carta da collo è un classico dei saloni da barbieri per evitare prurito al collo e che i peli possano entrare nei vestiti.*

### Packung 5 kraft halspapierrollen Confezione 5 rotoli di carta kraft

**RAGNAR**  
BARBER LINE

u.m.vta: 20  20 

REF. 07445

- 80 Servicios
- Stoffähnliches hautgefühl
- Sehr saugstark
- Atmungsaktiv und feuchtigkeitsbeständig
- Absolute hygienegarantie für ihre kunden
- Rohstoff aus nachhaltig bewirtschafteten und aufgeforsteten wäldern
- Wasserfest

- 80 Servizi
- Simile al tessuto al tatto
- Ottimo assorbimento di liquidi
- Traspirante e resistente all'umidità
- Garanzia assoluta di igiene per i tuoi clienti
- Materie prime da foreste ripopolate e controllate
- Waterproof



Ohne Tierquälerei  
Cruelty-Free



Ohne Chemikalien  
Senza sostanze  
chimiche



Nachhaltige Waldwirtschaft  
Foreste sostenibili





Kompostierbar  
Compostabile



Natürliches Produkt  
Prodotto naturale

### Packung 5 Rollen Barber Line Nackenpapier Confezione da 5 rotoli di carta da collo Barber Line

*Barber Line*

u.m.vta: 6  6 

REF. 04651

- 100 Anwendungen
- Weiß
- Weißer Klebstoff
- 100 servizi
- Bianca
- Colla nera

Packung 5 Rollen spezielles Friseur-Nackenpapier, schwarzer Klebstoff. Vorgeschnittene Packungseinheit



*Confezione da 5 rotoli di carta speciale per collo da barbieri, colla nera.*



## Packung 5 Rollen Barber Line Nackenpapier

### Confezione da 5 rotoli di carta da collo Barber Line



*Barber Line*

u.m.vta: 6  6 

REF. 06596



SCAN  
ME!

u.m.vta: 20  20 

REF. 06927

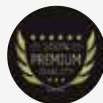

06596

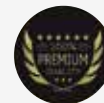

06927



- 80 Anwendungen
- Schwarz
- Weißer Klebstoff



- 80 servizi
- Nero
- Colla bianca

Recyceltes schwarzes Nackenpapier, das nicht verblasst, ist chlorfrei und könnte daher für Lebensmittel verwendet werden (ISEGA-zertifiziert). Außerdem ist es FSC- (Material aus kontrollierten Wäldern) und PEFC- (nachhaltige Waldbewirtschaftung) zertifiziert.

Carta da collo nera riciclata, non stinge, priva di cloro, potrebbe essere utilizzata anche per uso alimentare (certificata ISEGA). Possiede anche il certificato FSC (di materiale proveniente da foreste controllate) e PEFC (gestione forestale sostenibile).

## Rolle Nackenpapier

### Rotolo di carta da collo

u.m.vta: 100  100 

REF. 00681

- Blauer Klebstoff für einfaches Kleben und Platzieren
- Hochwertige Qualität
- Schnelle und perfekte Passform
- Hygienischer Einmalgebrauch
- Einwegpapier
- Elastisch und anpassbar an jeden Hals
- Entwickelt für professionelle Friseure und Barbieri
- Verhindert Juckreiz und Brennen am Hals

- Adesivo blu per facile fissaggio e posizionamento
- Qualità premium
- Fissaggio perfetto e veloce
- Monouso e igienico
- Carta usa e getta
- Elastico regolabile a ogni collo
- Progettato per parrucchieri e barbieri professionisti
- Evita il prurito e il bruciore al collo



SCAN  
ME!

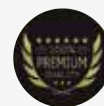

## Haar Pad Separatori di capelli

u.m.vta: 1  50 

Beutel mit 2 Pads. Klettverschluss  
Busta da 2 separatori. Velcro

REF.06440

REF.06613



06440



06613



## Halter für Nackenpapier Portarotoli per carta da collo

u.m.vta: 1  6 

REF. 00800

- Für Ref. 00681, 04651 und 06596
- Per rif. 00681, 04651 e 06596



## Halter für Nackenpapier Portarotoli per carta da collo

u.m.vta: 1  4 

REF. 06803

- Material: abs schwarz
- Kann an der wand aufgehängt werden
- Materiale: abs nero
- Può essere appeso alla parete



## Beutel mit 50 Augenschützern Busta da 50 protezioni per gli occhi

u.m.vta: 1  50 

REF. 06315



## Gehörschutz 50 Stück Protezione per le orecchie 50 unità

u.m.vta: 1  50

REF. 07008

- Abmessungen: 2\*4,5 cm
- Gewicht: 0,40 Gramm
- Plastisches Material

- Dimensioni: 2\*4,5 cm
- Peso: 0,40 grammi
- Materiale plastico



## Nackenumhang Silikon

### Mantella in silicone

u.m.vta: 1  10 

REF. 07006



## BARBER LINE Schneideumhang

### Mantella da taglio BARBER LINE

u.m.vta: 1  40 

REF.06988

- Pongee-Polyester
- Wasserabweisend
- Gewicht 150 gr
- Knopf-Verschluss

- Poliestere Pongee
- Idrorepellente
- Peso 150 g
- Chiusura a bottone

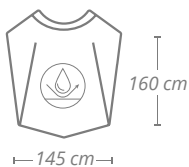

## EUROSTIL- Schneideumhang

### Mantella da taglio EUROSTIL

u.m.vta: 1  40 

REF.06989

- Pongee-Polyester
- Wasserabweisend
- Gewicht 150 g
- Knopf-Verschluss

- Poliestere Pongee
- Idrorepellente
- Peso 150 g
- Chiusura a bottone

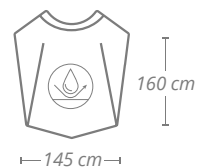

**RAGNAR - Schneideumhang**  
**Mantella da taglio RAGNAR**

**RAGNAR**  
 BARBER LINE

u.m.vta: 1  40

**NEW**

**American Old School**  
 REF. 07517



**Graffiti**  
 REF. 07518



**Aviator classic color**  
 REF. 07519



**Aviator classic**  
 REF. 07520





**Dolar american flag**  
 REF. 07521



Hakenverschluss  
 Chiusura a gancio

### Gestreifter Umhang Barberbole Mantella a righe barber

u.m.vta: 1  40 

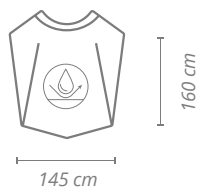

REF.06991



- Pongee-Polyester
- Wasserabweisend
- Gewicht: 150 Gramm
- Verschluss: Haken

- Poliestere Pongee
- Idrorepellente
- Peso: 150 grammi
- Chiusura: ganci



### Gestreifter Umhang Totenkopf Mantella a righe con logo

u.m.vta: 1  40 

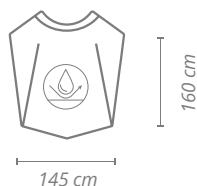
REF.06993



### Umhang Utensilien Mantella fantasia barber

u.m.vta: 1  40 

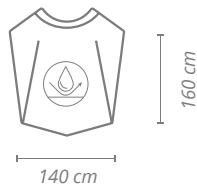

REF.06995



- Pongee-Polyester
- Wasserabweisend
- Gewicht: 150 Gramm
- Knopf-Verschluss

- Poliestere Pongee
- Idrorepellente
- Peso: 150 grammi
- Chiusura a bottone



### Schwarz-weiß gestreifter Umhang Mantella a righe bianche nere

u.m.vta: 1  40 

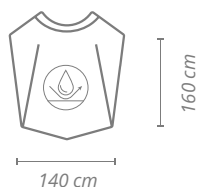
REF.06992



### Umhang Barber Shop Mantella Barber Shop

u.m.vta: 1  40 

REF.06997

- Pongee-Polyester
- Wasserabweisend
- Gewicht: 150 Gramm
- Knopf-Verschluss

- Poliestere Pongee
- Idrorepellente
- Peso: 150 grammi
- Chiusura a bottone

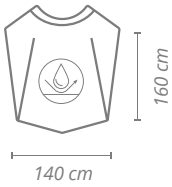

### EUROSTIL-Schneideumhang Mantella da taglio EUROSTIL

u.m.vta: 1  60

REF.04577

- Modell Totenkopf
- 100% Nylon
- Knopf-Verschluss

- Modello con teschio
- 100% nylon
- Chiusura a bottone

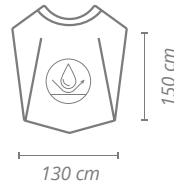

### Beutel 30 Capes schwarz Confezione da 30 mantelline nere

u.m.vta: 1  50

Einmaligen Gebrauch  
Monouso

REF. 07243

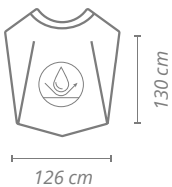

### Kunststoffumhang Färben Mantella in plastica per tintura

u.m.vta: 1  12

Groß, Klettverschluss  
Grande, Velcro

REF. 01174





## Schürze Jeansstoff mit Taschen

### Grembiule di jeans con tasche

u.m.vta: 1  10 

REF. 07010

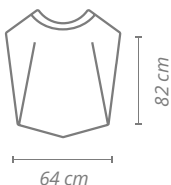
- Gewicht: 200 Gramm
- Peso: 200 grammi

u.m.vta: 1  10 



REF. 07057

- Gewicht: 200 gramm
- Schwarz mit details aus kunstleder
- Peso: 200 grammi
- Nero con dettagli in similpelle.



## Blaue Jeans Schürze BARBER LINE

### Grembiule in jeans blu BARBER LINE

u.m.vta: 1  10 



REF. 07058

- Gewicht: 200 Gramm
- Mit dem Logo der Barber Line gekennzeichnet
- Peso: 200 grammi
- Contrassegnato con il logo Barber Line



## BARBER LINE Schürze

### Grembiule BARBER LINE

u.m.vta: 1  60 

REF. 06182

- 3 Taschen, 1 obere, 2 untere
- 6 Unterteilunge, 1 obere und 5 untere
- 3 tasche, 1 superiore, 2 inferiori







## CAPTAIN COOK Schneideumhang

### Mantella da taglio CAPTAIN COOK

u.m.vta: 1  12

100% Nylon  
100% Nylon



REF.04975/50



REF.04975/58

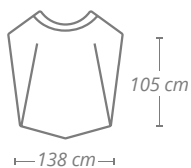

## CAPTAIN COOK Schürze

### Grembiule CAPTAIN COOK

u.m.vta: 1  60 

3 Taschen, 1 obere, 2 untere  
6 Unterteilungen, 1 obere und 5 untere  
3 tasche, 1 superiore, 2 inferiori

REF. 06181

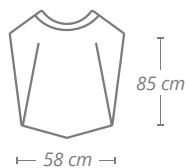

### Gestreifter Barbier Umhang Mantella da barbiere a righe

u.m.vta: 1  40

MOD. 21800976

REF. 06351

### Berberpole Umhang Mantella a righe da barbiere

u.m.vta: 1  40

MOD. 21800974

REF.06353

### Grauer Tarnumhang Mantella mimetica grigia

u.m.vta: 1  40

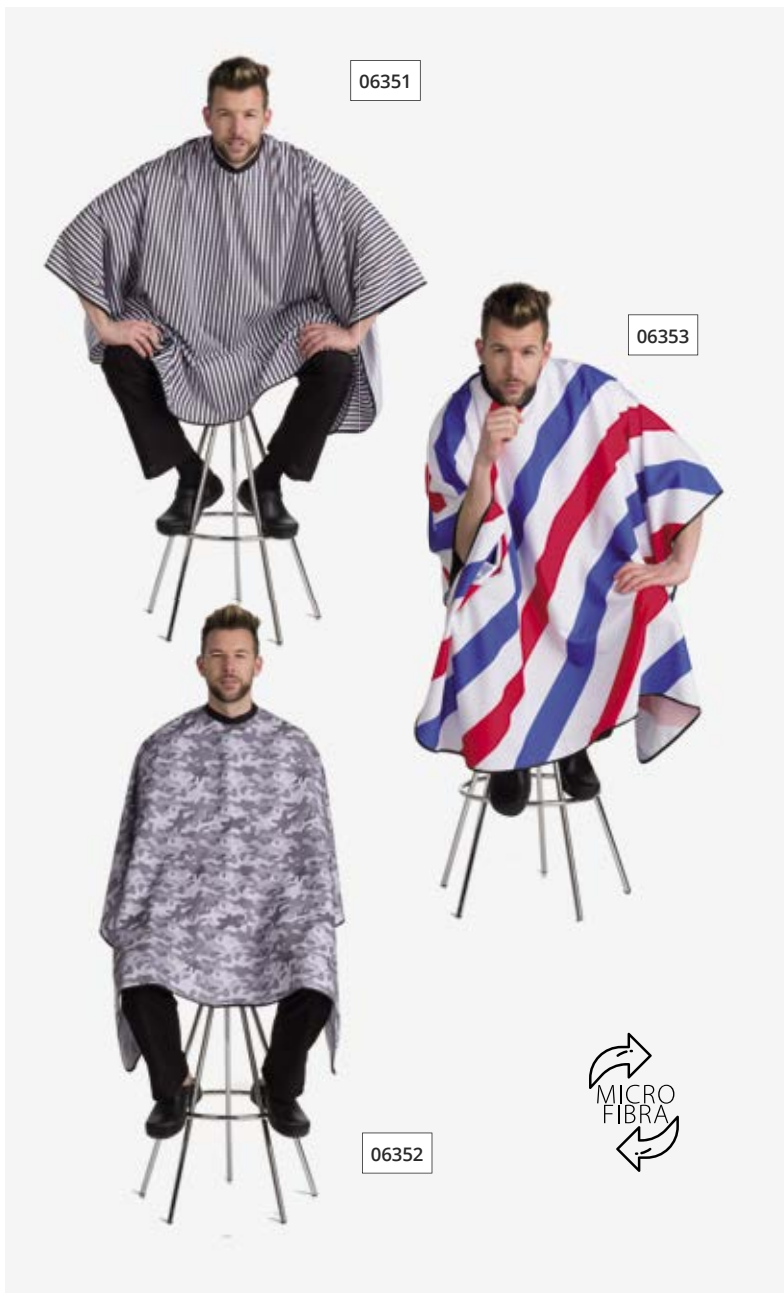

MOD. 21800975

REF.06352

Breite  
LarghezzaLänge  
Lunghezza

- 100% feiner Polyester
- Mit Schnappverschluss
- Leicht zu bügeln
- Ohne Dekor und antistatisch
- Einheitsgröße

- 100% poliestere fine
- Chiusura con bottone a pressione
- Facile da stirare
- Antistatico e non scolora.
- Taglia unica

131/132 cm   
143/144 cm 

## Kasack mit Mao-Kragen

### Camicia con colletto coreano

u.m.vta: 1 40

MOD. 51805305

REF.06357/50/3

L

118-122 cm  
120-124 cm  
74-76 cm

Länge  
Lunghezza



Brustumfang  
Petto

Hüfte  
Fianchi



Kasack mit Mao-Kragen und YKK-Reißverschluss. Taschen mit Lätzchen leicht zu bügeln. Ohne Dekor und antistatisch. 100% feiner Polyester.

Camicia con colletto alla coreano con cerniera YKK. Copritasche anti-peluria. Facile da stirare. Antistatica e non scolora. 100% poliestere fine

## Schürze aus Kunstleder

### Grembiule in similpelle

u.m.vta: 1 40

MOD. 31803151

REF.06350

28/29 cm  
66/67 cm  
81,50/82,50 cm



Brustumfang  
Petto

Hüfte  
Fianchi

Länge  
Length



Schürze aus glattem Kunstleder. Keine Taschen. Wasserdicht. Mit Nackenverstellung. Kunstleder

Grembiule in similpelle. Senza tasche. Impermeabile. Con regolazione sul collo. Similpelle

## Retro Jeans Schürze

### Grembiule retró in jeans

u.m.vta: 1 40

MOD. 31803155

REF.06355

27/28 cm

69/70 cm

81/82 cm

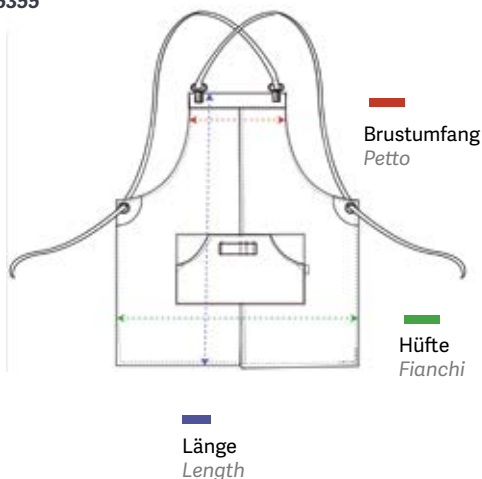

Elastische Retro Schürze aus Jeansstoff mit Details aus braunem Lackleder. Zentrale Tasche mit Applikation für Utensilien. Gekreuzte verstellbare Clips auf der Rückseite. Zentraler Schnitt. Einheitsgröße für alle.

- 60% Polyester, 37% Baumwolle, 3% elastisch

• Grembiule retró in jeans elasticizzato con dettagli in similpelle marrone. Tasca centrale con tasca per utensili. Clip di regolazione incrociate sul retro. Taglio centrale. Taglia unica.

- 60% poliestere, 37% cotone, 3% elastico

## Jeans Latzschürze

### Grembiule in jeans

u.m.vta: 1 40

MOD. 31603125

REF. 06310/50

25/26 cm

82/83 cm

81,50/82,50 cm

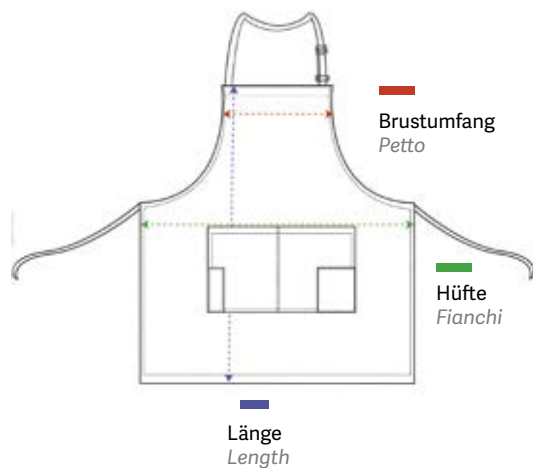

• Latzschürze aus elastischen Jeansstoff. Verstellung mit Gurt und Schlaufenverschluss. Mit 4 Taschen (mittlere Tasche in 2 + 2 kleine Unterteilungen). Einheitsgröße

- 60% Polyester, 37% Baumwolle, 3% elastisch

• Grembiule in jeans elasticizzato. Regolazione con cintura e chiusura con laccio. Con 4 tasche (tasca centrale divisa in 2 + 2 piccole). Taglia unica

- 60% poliestere, 37% cotone, 3% elastico

## Unisex-Hosen

### Pantaloni unisex

u.m.vta: 1	 40
------------	--

**MOD. 41300904**

- Hose aus feinem Polyester mit 3 Taschen. In der Taille mit einem Kordelzug verstellbar. Leicht zu bügeln. Ohne Dekor und antistatisch.
- 100% feiner Polyester
- *Pantaloni in poliestere fine con 3 tasche. Vita regolabile con laccio. Facile da stirare. Antistatico e non scolora.*
- 100% poliestere fine



**S**

- 96-96 cm
- 92-96cm
- 99-101 cm

**REF.06356/1**

**M**

- 102-106 cm
- 104-108cm
- 107-109 cm

**REF.06356/2**

**L**

- 110-114 cm
- 110-114 cm
- 107-109 cm

**REF.06356/3**

**XL**

- 112-116cm
- 114-118 cm
- 108-110 cm

**REF.06356/4**



**Länge**  
Length

**Taille**  
Girovita

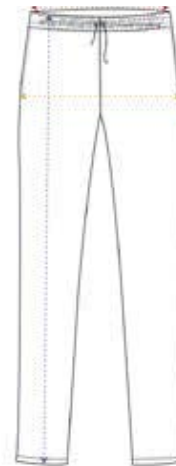
**Hüfte**  
Fianchi



### Sprühflasche Parfüm Barbier farbig Spruzzino Barber Line

u.m.vta: 1  10 

280 ml

REF.07000

- 6 Bernsteinfarben + 3 durchsichtig + 3 grau
- Material: Kunststoff
- Gewicht: 76 Gramm

- *Materiale plastico*
- *Peso: 76 grammi*



07000



07002



06998



25 cm

6,5 cm



06999



24,5 cm

7,5 cm

### Sprühflasche Barbier Totenkopf Spruzzino Barber Line teschio

u.m.vta: 1  10 



500 ml

REF.07002

- Mit japanischem Sprühkopf
- Material: Kunststoff
- Gewicht: 101 Gramm
- 6 Bernsteinfarben + 6 schwarz

- *Materiale: plastica*
- *Peso: 101 grammi*

### Sprühflasche Barbier farbig Spruzzino Barber Line

u.m.vta: 1  10 

500 ml



REF.06998

- 6 Bernsteinfarben + 3 durchsichtig + 3 grau
- Material: Kunststoff
- Gewicht: 76 Gramm

- *Materiale: plastica*
- *Peso: 76 grammi*



### Sprühflasche Barbier farbig Spruzzino Barber Line

u.m.vta: 1  10 



650 ml

REF.06999

- 6 Bernsteinfarben + 3 durchsichtig + 3 grau
- Material: Kunststoff
- Gewicht: 86 Gramm

- *Materiale: plastica*
- *Peso: 86 grammi*

## EUROSTIL-Sprühflasche Spray EUROSTIL

u.m.vta: 1  20 

30 ml



REF.07001

- Klare Flasche mit schwarzem Sprühkopf
- Material: Kunststoff
- Gewicht 45 Gramm

- *Bottiglia trasparente con sprayer nero*
- *Materiale: plastica*
- *Peso 45 g*



## Zerstäuber Atomizzatore

u.m.vta: 1  12 

300 ml

REF.04731

**Kontinuierliches Spray:** versprüht das Wasser mit nur einem Knopfdruck fein und gleichmäßig unter dem gleichen Druck von Beginn an bis zum letzten Tropfen.

**360°:** kann aus allen Winkeln verwendet werden, sogar mit der Düse nach unten. Feine Zerstäubung vom Typ Nebel, die das Wasser gleichmäßig auf das ganze Haar verteilt.

**Fassungsvermögen:** 300 ml nachfüllbar.

**Fixes Druckvolumen:** 1,25 cc kontinuierlich

**Verhindert das Ermüden** der Hand im Vergleich mit den Standard-Sprays. Ohne gasförmige Schadstoffe.

**Keine umweltschädlichen Gase**



300 ml

REF.04978

**Spray continu:** avec une seule pression, il pulvérise l'eau de manière fine et uniforme, avec la même pression du début jusqu'à la dernière goutte.

**360° :** il peut être utilisé depuis tous les angles, y compris la tête en bas. Pulvérisation fine, type brume, qui distribue l'eau de manière uniforme sur tous les cheveux

**Capacité :** 300 ml rechargeable.

**Volume fixe de pression :** 1,25 cc continu.

**Évite la fatigue de la main** par rapport à d'autres spray standards.

**Sans gaz contaminant.**

**RAGNAR**  
BARBER LINE



300 ml

REF.06243



## Zerstäuber Barber Line Spruzzini Barber Line

*Barber Line*



u.m.vta: 1  35 

Aluminium  
Alluminio

280 ml

REF.04837



u.m.vta: 1  12 



Talkum  
Talco

180 ml

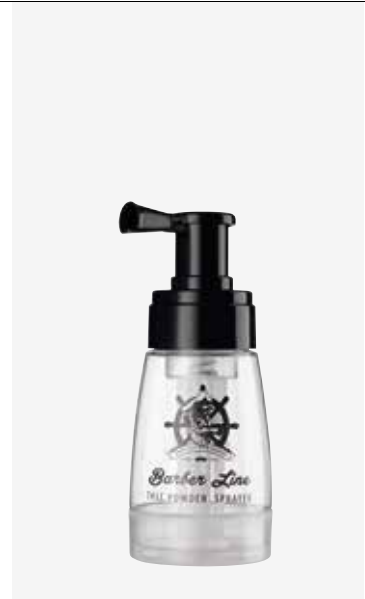
REF.06118



## Klassischer Talkumpuder-Zerstäuber BARBER LINE Classico per talco BARBER LINE

u.m.vta: 1  12 

180 ml

REF.06179



u.m.vta: 1  12



180 ml

REF.06178





**Sprühflasche Aluminium**  
**Spruzzino in alluminio**

u.m.vta: 1  35 

Innen lackiert  
*Interno laccato*

Neutral  
*Neutro*

280 ml

280 ml

REF.01384

REF.01384/02



**Stellkasten mit 30 Aluminium-Sprühflaschen**  
**Espositore 30 spruzzini in alluminio**

u.m.vta: 1  1

Eurostil  
*Eurostil*

Neutral  
*Neutro*



280 ml

280 ml

REF.01465

REF.01465/02



**Zerstäuber aus Kunststoff**  
**Spruzzino in plastica**

u.m.vta: 1  180 

Mit Anhänger  
*Con gancio*

130 ml

REF.03401

u.m.vta: 1  24 

Japanisch schwarz  
*Nero giapponese*

300 ml



REF.04377



### Barbier-Rucksack Zaino - Valigia per barbieri

u.m.vta: 1  4

REF.06797



- 4 große Fächer mit Reißverschluss
- Es hat mehr spezielle Innenfächer für Maschinen und Utensilien
- Material: Polyester-ähnlich Haut
- Verschlüsse an den Griffen mit Clip

- 4 ampi scomparti con chiusura a zip
- Dispone di scomparti interni per macchine e utensili
- Materiale: similpelle in poliestere
- Chiusura sui manici con clip



### Schwarzer Barbier-Koffer Valigetta nera da barbieri

u.m.vta: 1  12

REF.06438



### Kunstleder-Rollkoffer für Friseurbedarf (leer) Valigia trolley da parrucchiere (vuota)

Alle Koffer werden leer verkauft  
Tutte le valigie vengono vendute vuote

u.m.vta: 1  1

REF.04308



REF.06136



- 3 große Fächer mit 2 Ablagen oben mit Aussparungen für Utensilien
- 4 Räder für bequemen und einfachen Transport
- Mit abnehmbaren Rädern

- 3 ampi scomparti con 2 ripiani nella parte superiore con rientranze per riporre gli utensili
- 4 ruote per spostarlo in maniera comoda e facile
- Con ruote smontabili

## 4-Teiliger Rollkoffer Valigia trolley a 4 blocchi

u.m.vta: 1  1

REF.04943

Doppelterr Koffer mit Rollen. Der obere Kofferteil kann in einen Tragekofferrumgewandelt werden, der mit einem Schulterriemen ausgestattet ist. Er verfügt über zwei seitlich verschiebbare Innenfächer. Der Innenraum ist breit und der untere Teil ist abnehmbar und kunststoffbeschichtet, so dass der Koffer leicht zu reinigen ist. Auch auf der Rückseite hat er eine Außentasche.

Das untere Gehäuse mit Rädern hat eine kunststoffbeschichtete Innenseite und ist zur einfachen Reinigung abnehmbar. Es wird mit einem Bürstenhalter Abteil geliefert, der mittels eines Klettverschlusses befestigt wird. Dieses Abteil ist zwischen Ober und Unterkoffer austauschbar. Er verfügt über 8 Schubladen zum Aufbewahren und Sortieren kleiner Produkte und eine Tasche auf jeder Seite. Jedes Kofferteil hat 4 herausnehmbare Schubladen integriert, die in einem Stück zusammengefügt sind

*Valigia doppia in nylon con ruote. La valigia può essere convertita in un bagaglio a mano che viene fornito con una tracolla. Ha due ripiani interni che possono essere spostati sui lati. L'interno è spazioso e la parte inferiore è rimovibile e plastificata per facilitare la pulizia della valigia. Anche nella parte posteriore ha una tasca esterna.*

*La valigia inferiore, su ruote, ha una parte interna plastificata ed è rimovibile per rendere più facile la pulizia. Viene insieme con una coperta portaspazzole fissata con velcro. Questa coperta può essere scambiata tra la valigia superiore e quella inferiore. Dispone di 8 cassetti per riporre e separare piccoli prodotti e una tasca su ogni lato. Ogni colonna integra 4 cassetti estraibili uniti in un unico blocco.*



## Friseurtasche mit Rädern Trolley da parrucchiere

u.m.vta: 1  1

REF.04402/50

**Inklusive  
Toilettentasche (leer)**  
Beauty case (vuoto)  
incluso



- Mit einer Metallstruktur, die es ermöglicht, den Koffer als Sitz zu verwenden
- Con struttura in metallo che permette di utilizzare la valigia come seduta

## Rollkoffer Valigia trolley

u.m.vta: 1  1

REF.03814/50





## Friseurkoffer aus Aluminium Valigia da parrucchiere in alluminio

u.m.vta: 1  1

REF.04307

(Leer)  
(Vuota)

### Packung mit 75 CELLULOSE Handtüchern Confezione da 75 salviette CELLULOSA



u.m.vta: 1  16 50 g/m<sup>2</sup>

- Spezielle Maniküre
- Speciale per

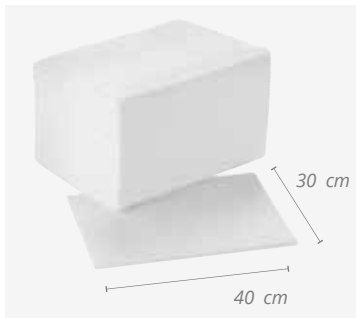
REF. 04204





### Packung mit 25 SPUNLACE Handtüchern Confezione da 25 salviette SPUNLACE

u.m.vta: 1  24 50 g/m<sup>2</sup>

40 x 90 cm

REF. 04916

u.m.vta: 1  28 50 g/m<sup>2</sup>

40 x 80 cm



REF. 03221

- Gefaltet auf 20 x 20 cm
- 50% Polyester / 50% Viskose

- Piegate 20 x 20 cm
- 50% poliestere / 50% viscosa





### Packung mit 90 CELLULOSE Handtüchern Confezione da 90 salviette CELLULOSA

u.m.vta: 4  144 55 g/m<sup>2</sup>

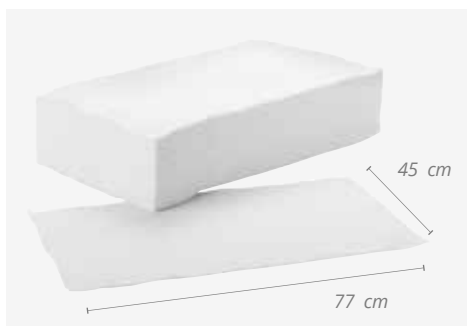
REF.04076



### Packung mit 100 SPUNLACE Handtüchern Confezione da 100 salviette SPUNLACE



u.m.vta: 4  20 

REF. 03283

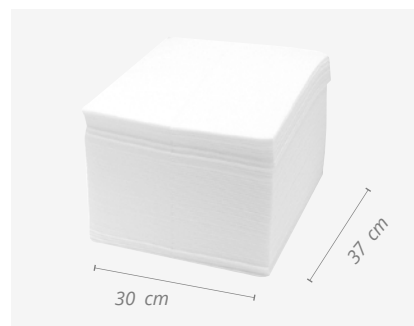
- Superabsorbierend
- Ultra assorbenti



### Beutel 25 Handtücher SPUNLACE Confezione da 25 salviette SPUNLACE

u.m.vta: 1  28 50 g/m<sup>2</sup>

REF. 07233

- Superabsorbierend
- Ultra assorbenti



### 35 SPUNLACE-Handtücher Confezione da 35 salviette PUNLACE

u.m.vta: 1  12 50 g/m<sup>2</sup>

REF. 04509

- Superabsorbierend
- Gefaltete Handtücher

- Ultra assorbenti
- Salviette piegate

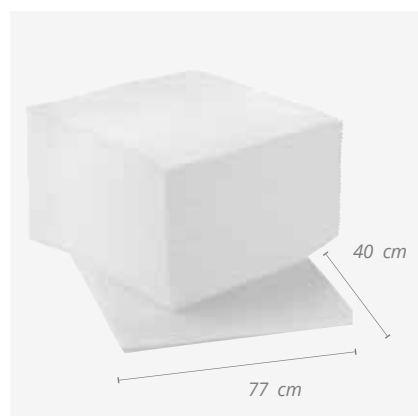

### Handtuch aus 100% Baumwolle Asciugamano 100% cotone

u.m.vta: 12  48 

380 g/m<sup>2</sup>

REF. 02947/50



REF. 04953/50

- Bleichmittelbeständig
- Resistente alla candeggina



380 g/m<sup>2</sup>

REF. 02901/50





380 g/m<sup>2</sup>

REF. 06829/50

- Bleichmittelbeständig
- Resistente alla candeggina



### Barbier-Handtuch aus 100% Baumwolle Asciugamano da barbiere 100% cotone

u.m.vta: 12  48 



380 g/m<sup>2</sup>

REF. 06413/50



## 100 HANDSCHUHE PE zum einmaligen Gebrauch und für eine astreine Hygiene

### 100 Guanti pe monouso

u.m.vta: 1  25 

REF. 07257

- Beidhändig
- Einheitsgröße
- Multifunktional

- *Ambidestro consente a ciascun guanto di essere usato per qualsiasi mano*
- *Taglia unica*
- *Multiuso*



## 100 transparente Polyethylenhandschuhe

### 100 Guanti polietilene trasparenti

u.m.vta: 100  100

REF. 07804

- 100% reines Polyethylen HDPE 0,7+/-2%g/pc
- Hypoallergen, undurchlässig, Einheitsgröße
- EPI Handelsklasse 1, angefertigt und gekennzeichnet CE
- Kompatibel mit Lebensmittelgebrauch 2011/10/CE
- 30 cm. hoch x 25 cm. Breit – Finger 15 cm breit Handgelenk

- *Polietilene hdpe 100% 0,7 +/- 2% g / pz*
- *Anallergici, impermeabile, taglia unica,*
- *DPI di categoria 1, prodotti e marcati CE,*
- *Compatibile con uso alimentare 2011/10 / CE*
- *30 Cm altezza x 25 cm larghezza x 15 larghezza polso*



## Beutel mit 100 Einweghandschuhen

### Confezione da 100 guanti monouso

u.m.vta: 1  100 

REF. 07304



### Schachtel 20 schwarze Latex-Handschuhe Confezione da 20 guanti neri in latex

LATEX / LATEX  
AQL 1,5

u.m.vta: 1  24 

S

REF. 02832

M

REF. 02833

L

REF. 02834

Erfüllt alle Vorschriften / Rispetta le normative: EN 374-1, EN 374-2, EN 374-3, CE





OHNE Pulver  
SENZA polvere



### Schachtel 100 schwarze Nitril-Handschuhe Confezione da 100 guanti in nitrile

NITRILE / NITRILE  
AQL 1,5

u.m.vta: 1  10 

S

REF. 06686

M

REF. 06687

L

REF. 06688

Cumple normativa / Rispetta le normative: EN 374-1, EN 374-2, EN 374-3, CE



OHNE Pulver  
SENZA polvere



### Plexiglas Scherenhalter Espositore per forbici

u.m.vta: 1  20

REF.04074



### Behälter für Scheren Contentitore per forbici

u.m.vta: 1  24

REF.04740



### Visitenkartenbox aus Aluminium Porta biglietti da visita in alluminio

u.m.vta: 1  400

REF.02470



### Taillengürtel für Utensilien Cintura portastrumenti

u.m.vta: 1  48

REF.04310



Alle Friseur Taschen werden leer verkauft  
Tutti i portautensili vengono venduti vuoti

## Etui für Utensilien Portastrumenti

u.m.vta: 1  48

**REF.03622** Mit 5 Unterteilungen (leer)  
Con 5 combinabili (vuoto)

u.m.vta: 1  48

**REF.03620**

u.m.vta: 1  48

**REF.03621**



## CAPTAIN COOK CAPTAIN COOK

u.m.vta: 1  48

Etui für Utensilien  
Astuccio per attrezzi

**REF.04979**

u.m.vta: 1  50

Schwarze Mütze  
Cappellino nero

**REF.07430**

u.m.vta: 1  1

Schwarzes T-Shirt  
Maglietta nera

S

**REF.04957/4**

M

**REF.04957/1**

L

**REF.04957/2**

XL

**REF.04957/3**







**Hydroalkoholische Lösung****Soluzione idroalcolica**u.m.vta: 1  63  u.m.vta: 1  23

100 ml

REF.07176



500 ml

REF.07177

u.m.vta: 1  7 



1 L

REF.07260

u.m.vta: 1  7 Mit dosierpumpe  
Con pompa dosatrice



1 L

REF.07214

**Hydroalkoholisches Gel mit Aloe Vera**  
**Gel idroalcolico con Aloe Vera**u.m.vta: 1  40 



100 ml

REF.07246

**Hydroalkoholisches Gel**  
**Gel idroalcolico**u.m.vta: 1  22 

500 ml

REF.07216

**Alkohol 96°**  
**Alcol 96°**u.m.vta: 1  12 

1 L

REF.07218



**Artikel, die ausschließlich in Spanien verkauft werden**  
**Articoli in vendita esclusiva IN SPAGNA**



**Antiseptikum Daromix GH**  
**Antisettico Daromix GH**

u.m.vta: 1  12

1 L

REF.06200

**Desinfektionsmittel Limoseptol**  
**Disinfettante Limoseptol**

u.m.vta: 1  20 

50 ml

REF. 06151

u.m.vta: 1  20

1 L

REF.06150





- AEMPS-Registrierungsnummer: 905-DE5
- Wasser-alkoholisches Antiseptikum zur hygienischen Händedesinfektion durch Reibung
- Wissenschaftlich garantierte Wirksamkeit
- Breites Biozidspektrum ab 30 sec
- Hypoallergene Formel
- Bewahrt die Hautfeuchtigkeit
- Keine Hautreizung
- Trocknet schnell
- Wirksam als: Bakterizid, Levurizid, Viruzid, Mikrobakterizid

- Numero di registrazione AEMPS: 905-DE5
- Antisettico idroalcolico per la disinfezione igienica delle mani per sfregamento
- Efficacia scientificamente garantita
- Biocida ad ampio spettro a partire da 30 sec
- Formula ipoallergenica
- Preserva l'idratazione della pelle
- Non irritante per la pelle
- Asciuga velocemente
- Efficace come: battericida, lieviticida, virucida, microbattericida

- Dosis: 100 ml in 10 l Wasser
- Zeit: 15 min
- AEMPS-Registrierungsnummer: 47-DE5
- Hochwertiges Produkt, das ausschließlich für die Hygiene, Reinigung und Desinfektion von professionellem Salonzubehör entwickelt wurde
- Waschmittelwirkung - Breites Spektrum
- Biologisch abbaubar - phosphatfrei und FORMOLFREI
- Keimtötende und desinfizierende Wirkung gegen: Bakterien, Hefen und Pilze

- Dose: 100 ml in 10 l d'acqua
- Tempo: 15 minuti
- Numero di registrazione AEMPS: 47-DE5
- Prodotto di alto livello sviluppato esclusivamente per l'igiene, la pulizia e la disinfezione degli utensili professionali nei centri estetici
- Azione detergente - Ampio spettro
- Biodegradabile - Senza fosfati e senza FORMOLO
- Efficacia germicida e DISINFETTANTE contro: batteri, lieviti e funghi

## Flasche speziell für hydroalkoholische Lösung und hydroalkoholische Lösung Speciale per gel e soluzione idroalcolica

u.m.vta: 1  3 



Mit wandhalterung  
Con supporto a parete

300 ml

REF.07278



## Große Sterilisator-Flasche Contentore in vetro per la disinfezione degli attrezzi

u.m.vta: 1  6 

1 L



REF.06141



- Ideal zum sterilisieren kleiner Utensilien
- Material: Glas

- Ideale per sterilizzare piccoli utensili
- Materiale: vetro



## Spiegel Specchi

u.m.vta: 1  10 

Schwarzer Spiegel  
Specchio nero

●  
REF. 02591/50



u.m.vta: 1  10 

T.V.-Spiegel  
Specchio TV

●  
REF. 00254/50



u.m.vta: 1  6 

REF. 01955/50 Professioneller Spiegel mit  
schwarzen Griffen  
Specchio professionale con  
maniglie nere



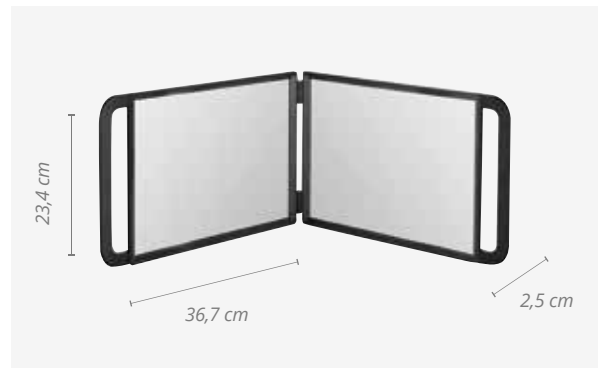

u.m.vta: 1  12

REF.04379 Professioneller Doppelspiegel  
Specchio professionale doppio



Spiegel mit schwarzem Griff aus EVA-Schaumstoff  
Specchio in schiuma EVA con manico nero

u.m.vta: 1  10 

REF. 02170



## Desinfizierende fußmatte

### Tappetino disinfettante per scarpe

u.m.vta: 1  12

REF.07234

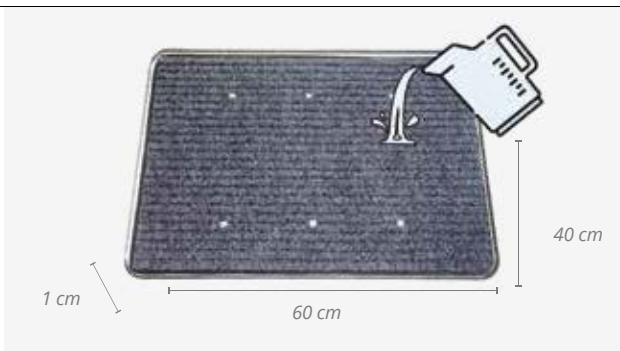

Extra flache Fußmatte mit nur 1 cm Höhe zur Verhinderung von Ausrutschern, hergestellt aus Polypropylen auf einer Gummiunterlage, enthält ionisiertes Aluminium. Maße: 60 cm Breite x 40 cm Länge x 1 cm Höhe/Dicke.

Verwendung: die Matte auf eine ebene, waagerechte Fläche legen, etwa 700 ml Desinfektionsflüssigkeit auf die Ablage auftragen. Es ist ratsam, einen Fußabtreter auf die Ablage zu legen, um die Schuhe des Kunden zu trocknen.

Tappetino extra piatto alto solo 1 cm per evitare inciampi, realizzato in polipropilene su base in gomma e contenitore in alluminio ionizzato. Misure: 60 cm di larghezza x 40 cm di lunghezza x 1 cm di altezza/spessore.

Modo d'uso: posizionare il tappetino su una superficie piana e livellata, applicare circa 700ml di liquido disinfettante sul vassoio. Si consiglia di posizionare un tappetino accanto al vassoio per asciugare le scarpe del cliente.

## Anti-fog Schutzbrille

### Occhiali protettivi antivapore

u.m.vta: 1  10 

REF.07256



- Schutz zur Prävention gegen Infektionen: schützt wirksam gegen Spritzer,
- Kies usw.
- Verwendungsort: jeder Ort, an dem Augenschutz erforderlich ist.
- Innovatives, komfortables Design. Passt sich perfekt an jede Kopfform und Kopfgröße an.
- Kann gleichzeitig mit Ihrer normalen Brille verwendet werden.
- EG-Zertifizierung
- Material: Kunststoff

- Protezione per prevenire le infezioni: proteggere efficacemente da schizzi, schegge, ecc.
- Luogo di utilizzo: qualsiasi luogo in cui è richiesta la protezione degli occhi.
- Confortevole design innovativo. Si adattano perfettamente a qualsiasi forma e dimensione della testa.
- Possono essere utilizzati contemporaneamente agli occhiali da vista.
- Certificato CE.
- Materiale: plastica

## Beutel 100 schuhüberzüge

### Copri-scarpe 100 unita

u.m.vta: 1  50

REF.07211



Einweg. Plastik  
Monouso. Plastico



**Automatischer wandgelspender mit tablet**  
**Erogatore automatico di gel da parete con vassoio**

u.m.vta: 1  12

1 L

REF.07271



**Automatischer tisch-gel-spender**  
**Erogatore automatico di gel da parete**

u.m.vta: 1  12

1 L

REF.07272



**Automatischer gelspender mit sockel**  
**Erogatore di gel automatico con treppiede**

u.m.vta: 1  12

1 L

REF.07273



**Manueller wandspender**  
**Erogatore manuale da parete**

u.m.vta: 1  12

700 ml

REF.07274



## Besen aus Gummi

### Scope di gomma

u.m.vta: 4	 16
------------	--

Mit Borsten  
Con linguetta

REF.01223



u.m.vta: 5	 20	
------------	--	---

REF. 01285/50



u.m.vta: 5	 20
------------	--

Rosca Spanisch und Italiana  
Rosca spagnola e italiana

REF.02420



• Die leicht zu reinigenden und langlebigen Borsten sind so konstruiert, dass sie den Staub mitreißen, ohne ihn anzuheben, was sie für Allergiker ideal macht, da sie eine saubere Umgebung begünstigen.

• Facile da pulire e di lunga durata, l'efficienza del design dei suoi denti riesce a trascinare la polvere senza sollevarla, rendendola ideale per chi soffre di allergie.

## Besenstiel

### Manico di scopa

Rosca Spanisch und Italiana  
Rosca spagnola e italiana

u.m.vta: 12	 12
-------------	--

REF.01131

- Leicht zu reinigen und langlebig
- Kunststoffhalter
- Ideal für alle Arten von Böden

- Facile da pulire e di lunga durata
- Gancio in plastica



u.m.vta: 10	 10
-------------	--

REF.01365

- Extra Teleskop
- Speziell für Parkett
- Telescopico extra





09

## Ausbildung Formazione

*Männliche Schaufensterpuppen,  
Halter, Stative...*

*Teste studio uomo,  
Supporti e Treppiedi*





# EURO *stil*

PROFESIONAL

## Männliche Schaufensterpuppe, 100% Teste studio uomo, CAPELLI 100% NATURALI

Mit Halterung  
Con supporto incluso 

u.m.vta: 1  10 

- 42 Implantate pro cm2
- 7-8 Haare pro Implantat
- Ca. 320 Haare pro cm2
- Zum Schneiden, Bleichen, Färben, Stylen, Trocknen und Glätten
- Maximale Temperatur 180°C

- 42 impianti per cm2
- 7-8 capelli per impianto
- 320 capelli circa per cm2
- Per tagliare, decolorare, tingere, acconciature, asciugatura e piastra
- Temperatura massima 180°C

### Castanie · Castano

REF. 02495

- Natürliches Implantat 45°

- *Impianto naturale 45°*

### Kastanie mit Bart · Castano con barba

REF. 02169

- Natürliches Implantat 45°.
- Auch zum Bartschneiden

- *Impianto naturale 45°*
- *Anche per taglio della barba*



## Männliche Schaufensterpuppe, 100%

### Testa di manichino uomo, CAPELLI 100% NATURALI

u.m.vta: 1  10 

- 42 Implantate pro cm<sup>2</sup>
- 7-8 Haare pro Implantat
- Ca. 320 Haare pro cm<sup>2</sup>
- Zum Schneiden, Bleichen, Färben, Stylen, Trocknen und Glätten
- Maximale Temperatur 180°C

- 42 impianti per cm<sup>2</sup>
- 7-8 capelli per impianto
- 320 capelli circa per cm<sup>2</sup>
- Per tagliare, decolorare, tingere, acconciare, asciugatura e piastra
- Temperatura massima 180°C

### Hellbraun · Castano chiaro

**Joe**

REF. 06147

- Natürliches Implantat 45°
- Impianto naturale 45°

**Joe**

REF. 04909

- Klassische 90°-Implantation
- Impianto naturale 45°



### Hellbraun mit Bart · Castano chiaro con barba

**Daniel**

REF. 06148

- Natürliche Implantate 45°
- Impianto naturale 45°

**Daniel**

REF. 04908

- Klassische 90°-Implantate
- Impianto naturale 45°



## Halterung für Trainingsköpfe

### Supporti per teste studio

u.m.vta: 1  25



REF. 00983

- Kunststoff
- Plastica

u.m.vta: 1  50

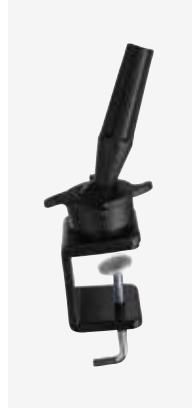

REF. 01461

- Kunststoff
- Plastica

u.m.vta: 1  100 

REF. 06276

- Kunststoff
- Plastica

u.m.vta: 1  10 

REF. 06162

9x10 units

- Kunststoff
- Plastica

u.m.vta: 1  12

REF. 03625

- Aluminium
- Alluminio





## Stativ Halterung für Trainingsköpfe

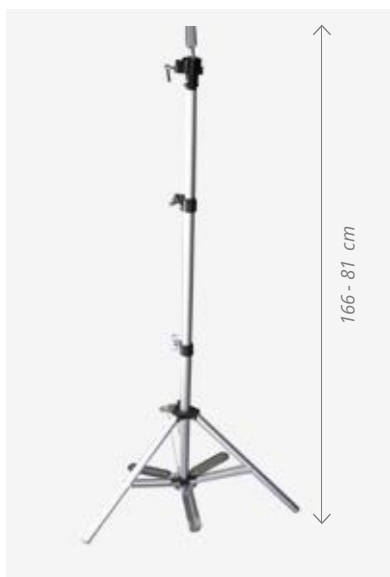

### Supporti a treppiede per teste studio

u.m.vta: 1  10

REF. 03738

u.m.vta: 1  6

REF. 03624

u.m.vta: 1  6 

REF. 01841







C/Ciudad de Asunción 56 · Barcelona 08030 (Spain)  
Tel. +34 93 274 07 84  
ventas@eurostil.com · export@eurostil.com