

BARBER
LINE
Industrias Oriol

Barbier
Barbería

Sans Prix / Sem Preços



EUROSTIL
PROFESSIONAL

RAGNAR
BARBER LINE



FEATHER®

MUSOL

DERBY®



ELIOS

pen RAZOR® by MAGIA

CLIPP-AID

BERGMANN

01 Appareils électriques Aparelhos elétricos 4

| | |
|---|----|
| Tondeuse cheveux RAGNAR · Máquinas de corte RAGNAR | 5 |
| Tondeuse cheveux CAPTAIN COOK | 12 |
| Máquinas de corte CAPTAIN COOK | |
| Tondeuse cheveux et retouche EUROSTIL | 14 |
| Máquinas de corte e retoque | |
| Tondeuse e retouche RAGNAR | 16 |
| Máquinas de retoque RAGNAR | |
| Tondeuse a retouche CAPTAIN COOK | 17 |
| Máquinas de retoque CAPTAIN COOK | |
| Tondeuse a retouche RAGNAR 360° | 20 |
| Máquinas de retoque RAGNAR 360° | |
| Tondeuse a retouche CAPTAIN COOK 360° | 21 |
| Máquinas de retoque CAPTAIN COOK 360° | |
| Tondeuses à barbe RAGNAR, BARBER LINE, CAPTAIN COOK | 22 |
| Máquinas de barbear RAGNAR, BARBER LINE, CAPTAIN COOK | |
| Tondeuse nez · Aparador nariz | 25 |
| Accessoires coupeuses (huiles) | 26 |
| Máquinas de corte de acessórios (óleos) | |
| Sèches-cheveux, chauffe-cire, fer à lisser | 28 |
| Secador, fusor de cera, alisador de cabelo | |
| Aspirateur · Aspirador de pó | 32 |
| Stérilisateur · Esterilizadores | 33 |

02 Rasoirs et rasoirs Navalhas e lâminas 36

| | |
|---|----|
| Rasoir RAGNAR · Máquina de barbear RAGNAR | 37 |
| Rasoir BARBER LINE · Máquina de barbear BARBER LINE | 39 |
| Rasoir CAPTAIN COOK · Máquina de barbear CAPTAIN COOK | 43 |
| Rasoir EUROSTIL · Máquina de barbear EUROSTIL | 45 |
| Rasoir FEATHER/ lames rasoirs | 46 |
| Máquina FEATHER / lâminas Navalhas | |
| Lames rasoirs · Lâminas navalhas | 47 |
| Rasoir jetables · Navalhas descartáveis | 48 |
| Pen razor, mousses et gels | 51 |
| Pen razor, espumas e géis | |

03 Ciseaux Tesouras 52

| | |
|--|----|
| Ciseaux RAGNAR · Tesouras RAGNAR | 53 |
| Ciseaux CAPTAIN COOK · Tesouras CAPTAIN COOK | 56 |
| Ciseaux BARBER LINE · Tesouras BARBER LINE | 59 |
| Ciseaux EUROSTIL · Tesouras EUROSTIL | 60 |
| Ciseaux initiation · Tesouras iniciação | 62 |
| Ciseaux spéciaux pour gauchers | 63 |
| Tesouras especial canhotos | |

04 Brosses & blaireaux rasage Escovas & pincéis 64

| | |
|------------------------------------|----|
| Brosses · Escovas | 65 |
| Talco · Talc | 67 |
| Brosses BARBER LINE / RAGNAR | 68 |
| Escovas BARBER LINE / RAGNAR | |
| Brosses EUROSTIL | 72 |
| Escovas EUROSTIL | |
| Brosses CAPTAIN COOK | 73 |
| Escovas CAPTAIN COOK | |

05 Peignes Pentes 74

| | |
|--|----|
| Peignes RAGNAR · Pentes RAGNAR | 75 |
| Peignes CAPTAIN COOK · Pentes CAPTAIN COOK | 79 |
| Peignes BARBER LINE · Pentes BARBER LINE | 81 |
| Peignes EUROSTIL · Pentes EUROSTIL | 82 |
| Peignes carbone · Pentes carbono | 83 |
| Peignes SILKOMB · Pentes SILKOMB | 84 |
| Peigne niveaux/Brosse de nettoyage peigne | 85 |
| Pente com níveis/Escova de limpeza pentes | |

06 Cosmétique Cosméticos 86

| | |
|----------------------|-----|
| RAGNAR | 87 |
| CAPTAIN COOK | 88 |
| THE SHAVING CO | 95 |
| MR.BEAR FAMILY | 99 |
| OSMA | 101 |
| MYRSOL | 102 |
| LEGEND | 106 |
| TASSEL | 107 |

07 Mobilier et décoration Mobiliário e decoração 110

| | |
|---|-----|
| Enseigne de barbier · Pólos barbeiro | 111 |
| Fauteuil de coiffure · Novo cadeira de barbeiro | 112 |
| Post-Lavages · Rampa de lavagem | 117 |
| Chaises coiffeur enfants · Assentos para crianças | 119 |
| Miroir · Espelho | 121 |
| Carriots et bidon · Carrinhos e bidão | 122 |
| Comptoir de réception et d'autres | 123 |
| Mostrador de recepção e outros | |

08 Accessoires Acessórios 128

| | |
|--|-----|
| Papler de cou · Papel pescoço | 129 |
| Capas · Capas | 132 |
| Vêtement homme LACLA | 138 |
| Vestuario de homem LACLA | |
| Pulvérisateur · Pulverizador | 142 |
| Valises · Maletas | 146 |
| Serviettes · Toalhas | 148 |
| Gants et accessoires · Luvas e acessórios | 150 |
| Désinfectant et stérilisateur, miroirs et balais | 153 |
| Desinfetante e esterilizador, espelhos e vassouras | |

09 Formation Formação 160

| | |
|--|-----|
| Têtes malléables EUROSTIL | 161 |
| Cabeças manequim EUROSTIL | |
| Têtes malléables BARBER LINE | 162 |
| Cabeças manequim BARBER LINE | |
| Supports et trépied · Soportes e tripé | 163 |

Les prix indiqués dans ce catalogue sont des prix recommandés, taxes en sus.
Les prix seront valables sauf erreurs typographiques.
Industrias Oriol 1942, S.L. se réserve le droit d'apporter des modifications sans préavis.

*Os preços listados neste catálogo são preços recomendados, impostos não incluídos.
Os preços serão válidos, exceto por erros tipográficos.
Industrias Oriol 1942, S.L. reserva-se o direito de fazer modificações sem aviso prévio.*

THUNDER

MÁQUINA CORTE RECARGABLE

Máquina de corte recargable THUNDER de "Crested Cook", diseñada para el uso del profesional. Motor potente y de larga duración, súper silencioso y de baja vibración. Fabricada con materiales de alta calidad y de última generación.



THUNDER

HAIR CLIPPER RECHARGEABLE



01

Appareils électriques Equipamentos

*Tondeuses, rasoirs, séchoirs,
tondeuse nez, chauffe-cires...*

*Máquinas de corte, máquinas de barbear,
secadores, máquina nariz, planchas ...*







*Puissance, qualité,
élégance et design*
*Potência, qualidade,
elegância e design*



RAGNAR
BARBER LINE

Tondeuse à cheveux GALAXY FADING Máquina de cortar cabelo GALAXY FADING

RAGNAR
BARBER LINE

 u.m.vta: 1  12 

REF. 07220



Spécial Fade
Especial Fade

- Prêt pour la décoloration
- Sans levier de réglage de la lame
- Lame fixe réglable de 0,2 à 0,3
- Tension : 100-240 V~.
- Fréquence : 50/60 Hz.
- Puissance : 8 W
- 5 500 tr/min (+/-100)
- Degré dégradation : 0,2- 0,3 mm
- Lame en Acier Japonais.
- Lame fixe en Titane.
- Brosse de nettoyage.
- Flaçon d'huile lubrifiante.
- Protection de lame.
- Source d'alimentation.
- Écran LCD multifonction.

- Pronto para desaparecer
- Sem alavanca reguladora de lâmina
- Lâmina fixa ajustável para 0,2 - 0,3
- Voltagem: 100-240V~
- Frequência: 50/60Hz.
- Potência: 8W
- 5500 r.p.m. (+/-100)
- Grau degradação: 0,2 - 0,3 mm
- Lâmina de Aço Japonês.
- Lâmina fixa de Titânio.
- Escova de limpeza.
- Frasco de óleo lubrificante.
- Protetor lâmina.
- Fonte de alimentação.
- Ecrã LCD multifunções.

Pièces de rechange · Recargas



Lame · Lâmina

REF.07389



Tondeuse à cheveux GALAXY CERAMIC Máquina de cortar cabelo GALAXY CERAMIC

Idéal pour travailler de longues heures
Ideal para trabalhar longas horas

u.m.vta: 1  12 

REF. 07221



Lame en céramique
Réduit l'échauffement de la lame
Lâmina de cerâmica
Reduz o aquecimento da lâmina

- Tension : 100-240 V~.
- Fréquence : 50/60 Hz.
- Puissance : 8 W
- 5 500 tr/min (+/-100)
- Degré dégradation : 0,5 mm
- Levier de réglage de la lame.
- LAME EN CÉRAMIQUE et lame fixe en titane.
- 6 sabots (1,5, 3, 4,5, 6, 10 et 13 mm).
- Brosse de nettoyage.
- Flacon d'huile lubrifiante.
- Protection de lame.
- Source d'alimentation.
- Écran LCD multifonction.
- Lame céramique

- Voltagem: 100-240V~
- Frequência: 50/60Hz.
- Potência: 8W
- 5500 r.p.m. (+/-100)
- Grau de degradação: 0,5mm
- Alavanca reguladora de lâmina.
- LÂMINA DE CERÂMICA e lâmina fixa de titânio.
- 6 pentes adaptadores de medida (1,5, 3, 4,5, 6, 10 e 13 mm).
- Escova de limpeza.
- Frasco de óleo lubrificante.
- Protetor lâmina.
- Fonte de alimentação.
- Ecrã LCD multifunções.
- Lâmina de cerâmica.

Pièces de rechange · Recargas

Lame · Lâmina

REF.07388

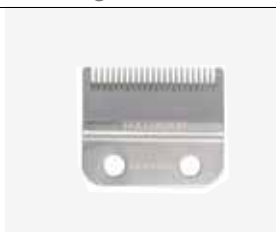

Tondeuse GALAXY
Máquina de corte GALAXY

RAGNAR
BARBER LINE



Ragnar
GALAXY
06714



SCAN
ME!



Ragnar
GALAXY
06714/50

SCAN
ME!



u.m.vta: 1  

REF. 06714

REF. 06714/50



- Levier réglage de la lame
- Lames en acier japonais
- 6 sabots accessoires longueurs de coupe 1,5, 3, 4,5, 6, 10, 12 mm
- Brosse de nettoyage
- Flacon huile lubrifiante
- Protection lame
- Source d'alimentation
- Écran LCD multifonction
- Puissance maximale: 8 W
- Tension : 100-240 V~
- Fréquence : 50/60 Hz
- Tours par minute : 5500+/-800 tr/min
- Degré dégradation : 0,5 mm

- Alavanca reguladora de lâmina
- Lâmina de aço japonês.
- 6 pentes (1,5, 3, 4,5, 6, 10 e 13 mm)
- Escova de limpeza
- Frasco de óleo lubrificante
- Protetor lâmina
- Fonte de alimentação
- Visor LCD multifunção
- Potência máxima: 8W
- Voltagem: 100-240V~
- Frequência: 50/60Hz
- Revoluções por minuto: 5500+/-100 rpm
- Grau de degradação: 0,5mm

Peignes · Pentas

| | | |
|---------------------------|--------------------------|---------------------------|
| 1,5 mm REF. RE06985/01 | 3 mm REF. RE06985/02 | 4,5 mm REF. RE06985/03 |
| 6 mm REF. RE06985/04 | 10 mm REF. RE06985/05 | 13 mm REF. RE06985/06 |

Pièces de rechange · Recargas



Lame · Lâmina

| | |
|-----------------------------|----------------------------------|
| Plat Plano REF. 06983 | Standard Padrão REF. 06984 |
|-----------------------------|----------------------------------|



Pack 6 peignes métalliques · Pack 6 pentas metálicos

REF. 06985



Tondeuse SUPERNOVA
Máquina de corte SUPERNOVA



RAGNAR
BARBER LINE



*Vouloir
savoir plus?
Quer
saber mais?*

**SCAN
ME!**



u.m.vta: 1  12 

REF. 06715

REF. 06715/50



- Levier réglage de la lame
- Lame en acier japonais
- 6 sabots accessoires longueurs de coupe 1,5, 3, 4,5, 6, 10, 13 mm
- Brosse de nettoyage
- Flaçon huile lubrifiante
- Protection lame
- Source d'alimentation
- Fonction turbo
- Écran LCD multifonction
- Puissance maximale : 8 W
- Tension : 100-240 V~
- Fréquence : 50/60 Hz
- Tours par minute : 5500+/-100 tr/min
- Turbo : 5700+/-100 tr/min
- Degré dégradation : 0,5 mm

- Alavanca reguladora de lâmina
- Lâmina de aço japonês.
- 6 pentes (1,5, 3, 4,5, 6, 10, 13 mm)
- Escova de limpeza
- Frasco de óleo lubrificante
- Protetor lâmina
- Fonte de alimentação
- Função turbo
- Visor LCD multifunção
- Potência máxima: 8W
- Voltagem: 100-240V~
- Frequência: 50/60Hz
- Revoluções por minuto: 5500+/-100 rpm
- Turbo: 5700/-100 rpm
- Grau de degradação: 0,5mm

Peignes · Pentas

| | | |
|---------------------------|--------------------------|---------------------------|
| 1,5 mm REF. RE06985/01 | 3 mm REF. RE06985/02 | 4,5 mm REF. RE06985/03 |
| 6 mm REF. RE06985/04 | 10 mm REF. RE06985/05 | 13 mm REF. RE06985/06 |

Pièces de rechange · Recargas



Lame · Lâmina

| | |
|-----------------------------|----------------------------------|
| Plat Plano REF. 06983 | Standard Padrão REF. 06984 |
|-----------------------------|----------------------------------|





Pack 6 peignes métalliques · Pack 6 pentas metálicos

REF. 06985



Tondeuse cheveux eagle avec cable

Máquinas de corte eagle com cabo

u.m.vta: 1  6 

REF. 06390





- Avec cable 2,5 m
- Comprend 6 peignes en métal et 2 lames
- Avec des lames en acier japonais
- Tension: 220-240V~
- Fréquence: 50 Hz
- Puissance maximale: 10W
- Tours par minute: 6500+/-800 rpm
- Convient à tout type de cheveux naturels
- Degré dégradation : 0,5 mm

- Com cabo 2,5 m
- Inclui 6 pentes de metal e 2 lâminas
- Com lâminas de aço japonesas
- Tensão: 220-240V ~
- Frequência: 50 Hz
- Potência máxima: 10W
- Revoluções por minuto: 6500 +/- 800 rpm
- Adequado para qualquer tipo de cabelo natural
- Grau de degradação: 0,5mm

Tondeuse cheveux FALCON sans cable

Máquinas de corte FALCON sem cabo

u.m.vta: 1  6 

REF. 06391



SCAN ME!



- Sans cable
- Comprend 6 peignes en métal et 2 lames
- Avec des lames en acier japonais
- Tension: 100-240V~
- Fréquence: 50/60Hz
- Puissance maximale: 5W
- Tours par minute: 5500+/-800 rpm
- Entrée adaptateur: 0,2 A
- Adaptateur de sortie: 5V 600mA
- Convient à tout type de cheveux naturels
- Degré dégradation : 0,5 mm

- Sem cabo
- Inclui 6 pentes de metal e 2 lâminas
- Com lâminas de aço japonesas
- Voltagem: 100-240V ~
- Frequência: 50 / 60Hz
- Potência máxima: 5W
- Revoluções por minuto: 5500 +/- 800 rpm
- Entrada do adaptador: 0.2 A
- Adaptador de saída: 5V 600mA
- Adequado para qualquer tipo de cabelo natural
- Grau de degradação: 0,5mm

Pièces de rechange · Recargas

Peignes · Pentes

| | | |
|----------------------------------|---------------------------------|----------------------------------|
| 1,5 mm REF. RE06602/01 | 3 mm REF. RE06602/02 | 4,5 mm REF. RE06602/03 |
| 6 mm REF. RE06602/04 | 10 mm REF. RE06602/05 | 13 mm REF. RE06602/06 |



Lame · Lâmina

Standard
Padrão
REF. 06603



REF. 07327

Plat
Plano

REF. 06604



REF. 07326



Pack 6 peignes métalliques · Pack 6 pentes metálicos

REF. 06602 Compatible avec 06390, 06391, 06666
Compatível com 06390, 06391, 06666



Tondeuse cheveux k-3600

Máquinas de corte k-3600

u.m.vta: 1 20

REF. 03752

REF. 03752/50



- Puissance: 5W
- Tension: 200-240V ~
- Fréquence 50Hz
- Adaptateur de sortie: 3V ~ 500mA
- Accessoires: 4 peignes
- Tête de coupe en céramique à mouvement réglable dans une mesure de coupe
- Lame fixe en titane
- Cable d'alimentation
- 2 piles rechargeables
- Brosse de nettoyage
- Burette d'huile de lubrification

- Potência: 5W
- Tensão: 200-240V ~
- Frequência 50Hz
- Adaptador de saída: 3V ~ 500mA
- Acessórios: 4 pentes
- Cabeça de corte em cerâmica com movimento regulável. Lâmina fixa de titânio
- Cabo de alimentação
- 2 baterias recarregáveis
- Escova de limpeza
- Frasco de óleo lubrificante



Temps de travail de 60/90 min
Tempo de operação 60 /90 Min



La batterie ou le courant électrique peuvent être utilisés
Pode usar-se com Bateria ou ligado à eletricidade



5h de charge
5h de carga



Tête de coupe en Céramique et lame en titane
Cabeça de cerâmica e lâmina de titânio



SCAN ME!



Peignes · Pentes

3 mm
REF. RE03752/07

6 mm
REF. RE03752/08

9 mm
REF. RE03752/09

12 mm
REF. RE03752/10



Pièces de rechange · Recargas

Tête · Cabeça

REF. RE03752/01

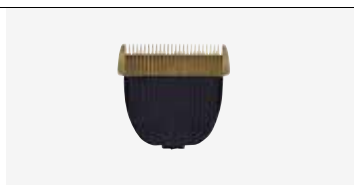



Batterie · Bateria

REF. RE03752/03



Tondeuse cheveux K-3000
Máquinas de corte K-3000

u.m.vta: 1  20 

REF. 03753



- Puissance: 3W
- Lames de 30 mm, 40 mm, 8 mm pour dessiner des motifs, nez / oreilles et tête de rasage
- lame interchangeable facile à nettoyer
- Faible vibration et très silencieuse
- LED Indiquant la charge
- Charge à long terme, jusqu'à 60 minutes d'autonomie
- Longueur de coupe réglable 4 niveaux : 3 mm, 6 mm, 9 mm et 12 mm



Machine à couper les cheveux professionnelle pour les retouches sur la barbe, le nez et les oreilles

Máquina de corte de cabelo profissional para retoques na barba, nariz e orelhas

- Potência: 3W
- Lâminas de 30 mm, 40 mm, 8 mm para detalhes, cabeça, nariz / orelhas Lâmina fácil de mudar e limpar
- Baixa vibração e muito silenciosa
- LED indicador de carga
- Carga de longa duração, até 60 minutos de autonomia
- Longitude ajustável de corte 4 níveis: 3 mm, 6 mm, 9 mm e 12 mm



Tête · Cabeça

Pour le nez
Nariz

Pour rasée
Barbeado

REF. RE03753/07

REF. RE03753/08

8 mm

30 mm

40 mm

REF. RE03753/06

REF. RE03753/04

REF. RE03753/05

Pièces de rechange · Recargas



Peignes · Pentas



REF. RE03753/01



Tondeuse de finition COSMIC

Máquina corte COSMIC touch-up

RAGNAR
 BARBER LINE

 u.m.vta: 1  20 

REF. 06713



REF. 06713/50



- Tête de coupe de 38 mm
- Lame fixe en acier oxydable
- Sabot adaptateur longueurs de coupe 2,3 et 4 mm
- Brosse de nettoyage
- Flacon huile lubrifiante
- Câble d'alimentation
- Bouton marche/arrêt
- Écran LCD multifonction
- Puissance maximale : 5 W
- Tension : 100-240 V~
- Fréquence : 50/60 Hz
- Tours par minute : 5500+/-100 tr/min

- Cabeça 38 mm
- Lâmina fixa de aço inoxidável
- Adaptador pentes (2, 3 and 4 mm)
- Escova de limpeza
- Frasco de óleo lubrificante
- Cabo de alimentação
- Botão on/off
- Visor LCD
- Potência máxima: 5W
- Voltagem: 100-240V~
- Frequência: 50/60Hz
- Revoluções por minuto: 5500+/-100 rpm

 SCAN
 ME!

Peignes · Pentas

2 mm

REF. RE06713/01

3 mm

REF. RE06713/02

4 mm

REF. RE06713/03

2 mm



3 mm



4 mm



Lame · Lâmina

REF.06982

 De coupe T-zero
 Aparadora T-zero

Pièces de rechange · Recargas



Tondeuse TRIUMPH Máquina de corte TRIUMPH

u.m.vta: 1 6

REF. 06667



- Sans cable
- Tête de coupe de 38 mm
- Lame fixe en acier oxydable
- Sabot accessoire longueurs de coupe 1,2 et 3 mm
- Brosse de nettoyage
- Flacon huile lubrifiante
- Câble d'alimentation
- **CHARGEUR**
- Bouton marche/arrêt
- Puissance maximale : 10 W
- Tension : 100-240 V~
- Fréquence : 50/60 Hz
- Tours par minute : 5500+/-800 tr/min.
- Degré dégradation : 0,1 mm

- Sem cabo
- Cabeça de corte de 38 mm
- Lâmina fixa de aço inoxidável
- Pente adaptador para medida de corte (1,2 e 3 mm)
- Escova de limpeza
- Frasco de óleo lubrificante
- Cabo de alimentação
- **BASE DE CARREGAMENTO**
- Botão de ON/OFF
- Potência máxima: 10W
- Voltagem: 100-240V~
- Frequência: 50/60Hz
- Revoluções por minuto: 5500+/-800 rpm
- Grau de degradação: 0,1mm



SCAN ME!

Nouveauté
Avec base de chargement
Novidade
Com base carregador

Peignes · Pentes

1 mm

REF. RE06667/05



2 mm

REF. RE06667/06

3 mm

REF. RE06667/07

Pièces de rechange · Recargas



Lame · Lâmina



REF. RE06667/01

Avec vis réglables
Com parafusos ajustáveis



Tondeuse THUNDER

Máquina de corte THUNDER

u.m.vta: 1  6 

REF. 06666



- Levier réglage de la lame
- 2 lames en acier japonais
- 6 sabots accessoires longueurs de coupe 1.5, 3, 4.5, 6, 10, 12 mm
- Brosse de nettoyage
- Flacon huile lubrifiante
- Protection lame
- Puissance maximale : 10 W
- Tension : 100-240 V~
- Fréquence : 50/60 Hz
- Tours par minute : 5500+/-800 tr/min
- Degré dégradation : 0,5 mm
- **SUPPORT DE CHARGE**

- Alavanca reguladora de lâmina
- 2 lâminas de aço japonês
- 6 pentes adaptadores de medida (1.5, 3, 4.5, 6, 10, 12 mm)
- Escova de limpeza
- Frasco de óleo lubrificante
- Protetor lâmina
- Potência máxima: 10W
- Voltagem: 100-240V~
- Frequência: 50/60Hz
- Revoluções por minuto: 5500+/-800 rpm
- Tours par minute : 5500+/-800 tr/min
- Grau de degradação: 0,5mm
- **BASE DE CARREGAMENTO**



Nouveauté
Avec base de chargement

Novidade
Com base carregador

Pièces de rechange · Recargas

pag. 423



Pack n°1 « 5ème anniversaire » CAPTAIN COOK
Pack n.º1 "5º Aniversário" CAPTAIN COOK

u.m.vta: 1 1

REF. 07276

Contient:

- Brosse Fade - 04977
- Ciseaux sculpteurs Black ripper 6" - 06479
- Tondeuse Thunder - 06666
- Trousse Captain Cook - 07079

Contém:

- Escova Fade - 04977
- Tesoura black ripper esculpir 6" - 06479
- Máquina de corte Thunder - 06666
- Nécessaire Captain Cook - 07079



Pack n°2 « 5ème anniversaire » CAPTAIN COOK
Pack n.º2 "5º Aniversário" CAPTAIN COOK

u.m.vta: 1 1

REF. 07330

Contient:

- Tondeuse Thiumph - 06667
- Brosse Fade - 04977
- Ciseaux sculpteurs 6" Black ripper - 06479
- Trousse Captain Cook - 07079

Contém:



- Máquina de corte Thiumph - 06667
- Escova Fade - 04977
- Tesoura esculpir 6" Black ripper - 06479
- Nécessaire Captain Cook - 07079



Tondeuse à retouche AIRFLIP

Máquina retoque AIRFLIP

RAGNAR
 BARBER LINE

 u.m.vta: 1  6 

REF. 07282



- Tension : 100-240 V~
- Fréquence : 50/60 Hz.
- Puissance : 8 W
- 6 500 tr/min (+/-500)
- Tête de coupe de 38 mm
- Protection de lame
- Lame fixe en Acier Inoxydable
- Sabot adaptateur pour coupe à 1, 2 et 3 mm
- Brosse de nettoyage.
- Flacon d'huile lubrifiante
- Câble d'alimentation
- **SUPPORT DE CHARGE**
- Couvercle transparent
- Degré de dégradation : 0,1 mm

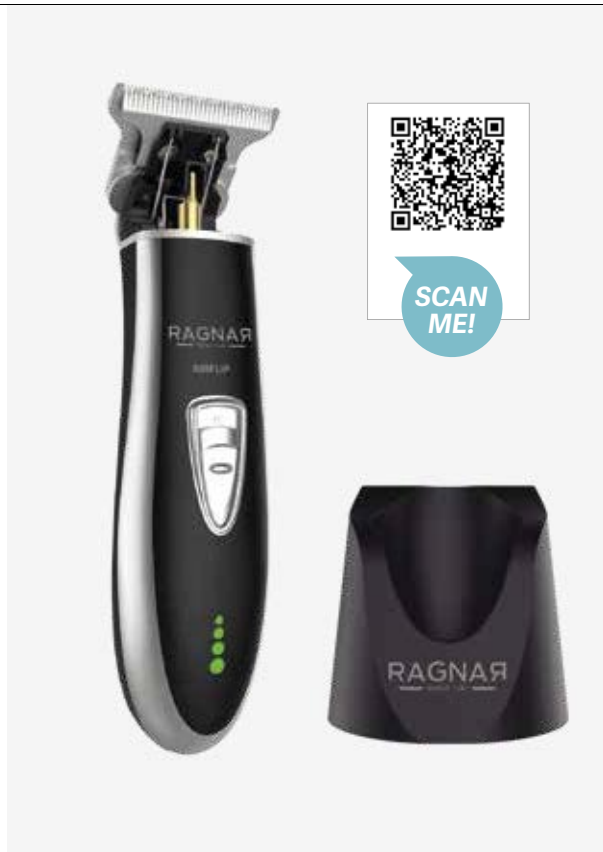

- Voltagem: 100-240V~
- Frequência: 50/60Hz.
- Potência: 8W
- 6500 r.p.m. (+/-500)
- Cabeça de corte de 38 mm
- Protetor lâmina
- Lâmina fixa de aço inoxidável
- Pente adaptador para medida de corte (1,2 e 3 mm)
- Escova de limpeza.
- Frasco de óleo lubrificante
- Cabo de alimentação
- **BASE DE CARREGAMENTO**
- Tampa transparente
- Grau de degradação: 0,1mm

 Vision coupe de la lame
 Visão corte de lâmina

Peignes · Pentas

1 mm

REF. RE07282/01

2 mm

REF. RE07282/02

3 mm

REF. RE07282/03



Pièces de rechange · Recargas

1 mm

2 mm

3 mm



Lame · Lâmina

REF.07324



Tondeuse à retouche DRAKE

Máquina retoque DRAKE



u.m.vta: 1 20

REF. 07283



- Tension : 100-240 V~.
- Fréquence : 50/60 Hz.
- Puissance : 8 W
- 7000+/-500 tr/min.
- Tête de coupe de 38 mm.
- Lame fixe en Acier Inoxydable.
- Sabot adaptateur pour coupe à 1, 2 et 3 mm.
- Brosse de nettoyage.
- Flacon d'huile lubrifiante.
- Câble d'alimentation.
- Couvercle transparent.
- Degré dégradation : 0,1 mm

- Voltagem: 100-240V~
- Frequência: 50/60Hz.
- Potência: 8W
- 7000+/-500 rpm.
- Cabeça de corte de 38 mm.
- Lâmina fixa de aço inoxidável.
- Pente adaptador para medida de corte (1,2 e 3 mm).
- Escova de limpeza.
- Frasco de óleo lubrificante.
- Cabo de alimentação.
- Tampa transparente.
- Grau de degradação: 0,1mm



Vision coupe de la lame
Visão corte de lâmina



Lame · Lâmina



Pièces de rechange · Recargas

REF.07325



Tondeuse COMET

Navalha COMET

u.m.vta: 1  20 

RAGNAR
BARBER LINE

REF. 07084/50

REF. 07084/54



SCAN
ME!

Merci d'avoir choisi notre nouvelle tondeuse COMET 07084/50-07084/54, rechargeable, de « RAGNAR », conçues pour un usage professionnel. Moteurs puissants et endurants, très silencieux et de faible vibration. Fabriquées avec des matériaux de haute qualité et de dernière génération.

- Voltage : 100-240 V~
- Fréquence : 50/60 Hz
- Entrée adaptateur : 0,2 A
- Sortie adaptateur : 5V 1000mA
- Révolutions par minute : 8.000-9.000 rpm
- Puissance maximale : 5 W
- Temps de charge : 3 heures
- Temps en fonctionnement : plus de 80 minutes
- Batterie lithium
- Apte pour tout type de poils naturels
- Conditions environnementales idéales pour son utilisation: utilisation en intérieur
- Température de -5° à 40°C
- Humidité relative égale ou inférieure à 80%

Obrigado por ter escolhido a nossa nova navalha COMET 07084/50-07084/54 recarregável de "RAGNAR", concebidas para uso profissional. Os seus potentes motores de longa duração são supersilenciosos e de baixa vibração. Os mesmos foram fabricados com materiais de alta qualidade e de última geração.

- Voltagem: 100-240V~
- Frequência: 50/60Hz
- Potência máxima: 5W
- Revoluções por minuto: 8.000-9.000 rpm
- Entrada adaptador: 0,2 A
- Saída adaptador: 5V 1000mA
- Tempo de carregamento: 3 horas
- Tempo de funcionamento: mais de 80 minutos
- Pilha de lítio
- Apta para qualquer tipo de cabelo natural
- Condições ambientais idóneas para a sua utilização: utilização em interiores
- Temperatura -5° a 40°C
- Humidade relativa igual ou menor a 80%;



Tête complète avec lame

Cabeça completa com lâmina

Pièces de rechange · Recargas

u.m.vta: 1  100 



REF. RE07084/50/01





REF. RE07084/54/01



Tondeuse BUCANERO

Navalha BUCANERO

Barber Line

u.m.vta: 1  24 

REF. 06412/50

Merci d'avoir choisi notre nouvelle tondeuse BUCANERO 06412 rechargeable "Barber Line", conçue pour un usage professionnel. Moteur puissant et durable, très silencieux et peu vibrant. Fabriqué avec des matériaux de haute qualité et de dernière génération.

- Voltage : 100-220V~
- Fréquence: 50/60Hz
- Puissance: 3W
- Révolutions par minute: 6800 rpm
- Entrée adaptateur: 3-5 W
- Sortie adaptateur : 2 W.
- Temps de charge: 2 heures
- Temps en fonctionnement : plus de 90 minutes
- Batterie lithium
- Apte pour tout type de poils naturels

Obrigado por escolher nossa nova navalha BUCANERO 06412 "Barber Line", projetada para uso profissional. Motor potente e duradouro, super silencioso e com baixa vibração. Fabricado com alta qualidade e materiais de última geração.

- Frequência: 50/60Hz
- Potência: 3W
- Revoluções por minuto: 6800 rpm
- Entrada adaptador: 3-5 W
- Saída adaptador: 2 W
- Tempo de carregamento: 2 horas
- Tempo de funcionamento: mais de 90 minutos
- Bateria de lítio
- Apta para qualquer tipo de cabelo natural





SCAN ME!



Tête complète avec lame

Cabeça completa com lâmina

u.m.vta: 1  12 

REF. RE06412/01



REF. RE06412/50/01

Pièces de rechange · Recargas



Tondeuses ROADSTER

Máquinas de barbear ROADSTER

u.m.vta: 1  12 

REF. 06411

Nous vous remercions d'avoir choisi notre tondeuse rechargeable ROADSTER 06411 de «Captain Cook», conçu pour un usage professionnel. Moteur puissant et durable, très silencieux et peu vibrant. Fabriqué avec des matériaux de haute qualité et de dernière génération.

- Fréquence: 50/60Hz
- Puissance: 3W
- Révolutions par minute: 6800 rpm
- Entrée adaptateur: 3-5 W
- Sortie adaptateur : 2 W
- Temps de charge: 2 heures
- Temps en fonctionnement : plus de 90 minutes
- Batterie lithium
- Apte pour tout type de poils naturels



Obrigado por escolher nosso novo Barbeador Recarregável ROADSTER 06411 da "Captain Cook", projetado para uso profissional. Motor potente e duradouro, super silencioso e com baixa vibração. Fabricado com alta qualidade e materiais de última geração.

- Frequência: 50/60Hz
- Potência: 3W
- Revoluções por minuto: 6800 rpm
- Entrada adaptador: 3-5 W
- Saída adaptador: 2 W
- Tempo de carregamento: 2 horas
- Tempo de funcionamento: mais de 90 minutos
- Bateria de lítio
- Apta para qualquer tipo de cabelo natural



Tête complète avec lame

Cabeça completacom lâmina

u.m.vta: 1  12 

REF. RE06411/01

Pièces de rechange · Recargas



Tondeuse nez EUROSTIL Máquina nariz EUROSTIL

Batterie non incluse
Bateria não incluída

EUROstil
PROFESSIONAL

u.m.vta: 1  100 

REF. 04268

- Elle peut être mouillée
- Avec la base et 2 accessoires.

- Pode molhar-se
- Com base e 2 acessórios



REF. 04269

- Elle ne peut pas être mouillée
- Não pode se molhar



Tondeuse-stylo de retouche Máquina corporal

Batterie non incluse
Bateria não incluída



u.m.vta: 1  100 

REF. 04270



- Conception ergonomique
- Respectueuse avec la peau sensible
- Interrupteur marche / arrêt
- 2 niveaux de coupe: pour 2 mm de long / pour 5 mm de long
- Housse de protection
- Tête d'angle pour une utilisation facile
- Alimentation
- 1 pile AAA (non incluse)

- Design Ergonómico
- Suave com a pele sensível
- Botão con/off
- 2 Níveis de corte: para 2 mm de comprimento/ para 5 mm de comprimento
- Tampa protetora
- Cabeça em ângulo para facilitar a sua utilização
- Fonte de alimentação
- 1 Pilha AAA (Não incluída)

Huiles 500 ML**Óleos 500 ML**u.m.vta: 1  12 Parfum intense
Perfume intenso

500 ml

REF. 06272

RAGNAR
BARBER LINE

500 ml



- Parfum doux
- Perfume suave

REF. 06395





500 ml



Huile pour tondeuses à usage professionnel. Réfrigérant, désinfectant, lubrifiant et antioxydante, ce qui la rend indispensable pour un entretien optimum des lames. Pulvériser à une distance d'environ 15-20 cm de la partie supérieure et latérale de la tête de la machine.

Óleo para máquinas de utilização profissional. Refrigerante, higienizante, lubrificante e antioxidante o que o torna imprescindível para uma manutenção ótima das lâminas. Pulverize a uma distância de 15-20 cm, aproximadamente, da parte superior e lateral da cabeça da máquina.

Bouteille d'huile**Garrafa de óleo**u.m.vta: 1  10 Lubrifiante
Lubrificante

100 ml

REF. 03751

100 ml



Cette huile spécialement conçue pour les tondeuses à cheveux de la marque Eurostil est une huile minérale légère qui améliore le temps de levage de la lame améliorant ainsi sa coupe. Non irritante.

Este óleo especial para máquinas de cortar da marca Eurostil é um óleo mineral leve que melhora o tempo de elevação da folha melhorando assim o corte da mesma. Não irrita.

Tapis barbier RAGNAR
Tapete de barbeiro RAGNAR

Matériel: caoutchouc
 Material: borracha

u.m.vta: 1  5

REF. 07386



Tapis barbier CAPTAIN COOK
Tapete de barbeiro CAPTAIN COOK

Matériel: caoutchouc
 Material: borracha

u.m.vta: 1  5

REF. 07387



Sèche-cheveux COMPACT PROFESSIONNEL

Secador COMPACT PROFESSIONAL

u.m.vta: 1

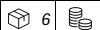

REF. 04202



**Vouloir
savoir plus?**
Quer
saber mais?

**SCAN
ME!**

Motor puissant
(avec générateur d'ions)

Motor patente
com gerador de iões



Le sèche-cheveux compact professionnel a un design attrayant, ergonomique et léger. Disponible en noir et en blanc ainsi qu'il est doté d'une finition en caoutchouc colorée pour l'empêcher de glisser. Moteur puissant avec générateur d'ions. Comprend deux buses de tailles différentes.





- Puissance: 2000W
- Moteur à courant alternatif (AC) compact de longue durée
- Poids: 580 g
- Débit d'air: 90 m³/heure
- 2 vitesses · 3 températures
- Bouton d'air froid
- 2 buses réglables de 62mm et 70mm
- Filtre amovible
- Thermostat de sécurité
- Câble souple de 3m avec anneau de suspension
- Faible niveau sonore
- Tension 220-240V~
- Fréquence: 50/60 Hz
- Design ergonomique
- Boîtier robuste et léger en polyamide
- Finition en caoutchouc antidérapant
- Moteur générateur d'ions
- Compatible avec les diffuseurs : 04346/50 - 01147 - 03036/50

O Secador Compact Professional tem um design atrativo, ergonómico e leve. Disponível em branco, preto e branco com borrachas coloridas. Motor potente, com gerador de iões. Inclui dois bicos de diferentes dimensões.

- Potência: 2000W
- Motor compacto de longa duração (AC)
- Peso: 580 g
- Fluxo de ar: 90 m³/hora
- 2 velocidades · 3 temperaturas
- Botão de ar frio
- 2 bicos direcionáveis de 62mm e de 70mm
- Filtro extraível
- Termóstato de segurança
- Cabo flexível de 3m com anel para pendurar
- Silencioso
- Voltagem 220-240V ~
- Frequência: 50/60 Hz
- Design ergonómico
- Exterior robusto e leve em Poliamida
- Capa de borracha antiderrapante
- Motor gerador de iões
- Compatível com difusores: 04346/50 - 01147 - 03036/50

Sèche-cheveux COMPACT ULTRA LIGHT

Secador COMPACT EXTRA LIGHT

u.m.vta: 1  6 u.m.vta: 1  12 

REF. 04203



REF. 04203/58



Le sèche-cheveux compact professionnel a un design attrayant, ergonomique et léger. Disponible en noir et en blanc. Doté d'une finition en caoutchouc colorée pour l'empêcher de glisser. Moteur puissant avec générateur d'ions. Comprend deux buses de tailles différentes.

- Puissance: 1800W
- Moteur à courant alternatif (DC) compact de longue durée
- Poids: 430 g
- Débit d'air: 76 m³/heure
- 2 vitesses · 3 températures
- Bouton d'air froid
- 2 buses réglables de 62mm et 70mm
- Filtre amovible
- Thermostat de sécurité
- Câble souple de 3m avec anneau de suspension
- Faible niveau sonore
- Tension 220-240V~
- Fréquence: 50/60 Hz
- Compact et PLUS LÉGER
- Finition en caoutchouc antidérapant
- Moteur générateur d'ions
- Compatible avec les diffuseurs : 04346/50 - 01147 - 03036/50



O Secador Compact Profissional tem um design atrativo, ergonômico e leve. Disponível em branco, preto e branco com borrachas coloridas. Motor potente, com gerador de iões. Inclui dois bicos de diferentes dimensões.

- Potência: 1800W
- Motor compacto de longa duração (DC)
- Peso: 430 g
- Fluxo de ar: 76 m³/hora
- 2 velocidades · 3 temperaturas
- Botão de ar frio
- 2 bicos direcionáveis de 62mm e de 70mm
- Filtro extraível
- Termóstato de segurança
- Cabo extraflexível de 3m com anel para pendurar
- Silencioso
- Voltagem 220-240V ~
- Frequência: 50/60 Hz
- Compacto e MAIS LEVE
- Capa de borracha antiderrapante
- Motor gerador de iões
- Compatível com difusores: 04346/50 - 01147 - 03036/50

Sèche-cheveux robust barber line

Secador robust barber line

Barber Line

u.m.vta: 1  12 

REF. 06475



SCAN ME!



Conçu comme le complément idéal pour le coiffeur, le nouveau sèche-cheveux ROBUST d'Barber Line apporte un haut débit d'air, un plus grand rendement et une diminution du temps de séchage. Il permet de réaliser tout type de coiffure: lissage, cheveux bouclés, augmentation du volume, etc. Vos cheveux seront plus doux, plus brillants et pleins de vie.

- Puissance: 1900W - 2200W
- Tension: 220-240V~
- Fréquence: 50/60 Hz

Realizado como complemento ideal para o cabeleireiro. O novo secador de cabelo ROBUST de Barber Line oferece um grande fluxo de ar, um aumento do rendimento e a redução do tempo de secagem. Permite criar qualquer tipo de penteado: lisos, ondulados, volume etc. Cabelo estará suave, brilhante e saudável.

- Potência: 1900W - 2000W
- Voltagem: 220-240V ~
- Frequência: 50/60 Hz



Chauffe-cire noir barber line 125 ml

Panela de cera preto barber line 125 ml

Barber Line

u.m.vta: 1  12 

REF.04505





- Chauffe-cire compact
- Surface antiadhésive, facile à nettoyer
- Température réglable
- Chauffe rapide
- Couvercle de protection
- Capacité: 125 ml
- Tension: 220-240V~
- Puissance: 40W
- Fréquence: 50 Hz
- Température maximale 90°C

- *Panela de cera compacto*
- *Superfície antiaderente para facilitar a limpeza*
- *Ajustes de temperatura variável*
- *Aquecimento rápido*
- *Capa protetora*
- *Capacidade: 125 ml*
- *Voltagem: 220 – 240 V~*
- *Frequência: 50Hz*
- *Potência: 40W*
- *Temperatura máxima 90°C*



Fer à lisser petit barber line pour barbe et frange

Prancha pequena, barber line para barba e franja

u.m.vta: 1  20 

REF. 06569/50



Les nouveaux fers à lisser Mini Barber Line permettent de créer tout type de coiffure ondulée, lisse etc. Utilisation professionnelle.

- Fer à cheveux en céramique et tourmaline qui prend soin des cheveux et leur apporte brillance et douceur
- Tension: 100 - 240 V ~
- Fréquence : 50/60 Hz
- Puissance 22 W
- Câble en caoutchouc de 2 m
- Échauffement des plaques en seulement 30 secondes, avec une résistance de type PTC
- Température maximale 200°C
- Résistance PTC qui évite les surchauffes
- Apte pour tout type de cheveux naturels
- NE PAS UTILISER SUR LES CHEVEUX SYNTHÉTIQUES
- NE PAS UTILISER SUR LES CHEVEUX MOUILLÉS

As novas pranchas Mini Barber Line permitem criar qualquer tipo de penteado ondulado, liso, etc. Utilização profissional.

- Placas de Cerâmica com Turmalina que cuidam do cabelo proporcionando brilho e suavidade
- Tensão: 100-240 V~
- Frequência: 50/60 Hz
- Potência 22 W
- Cabo de borracha
- Aquecimento de placas em apenas 30 segundos, com resistência PTC
- Temperatura máxima 200°C
- Resistência PTC que evita o sobreaquecimento
- Adequada para qualquer tipo de cabelo natural
- NÃO USAR EM CABELO SINTÉTICO
- NÃO ADEQUADA PARA CABELO MOLHADO

Aspirateur à cheveux Aspirador de pó

u.m.vta: 1  1 

REF. 06612

P.V.P.R 187,72€

SCAN
ME!Réservoir
DepósitoBouton
manuel
Botão
manualEntrée
de terre
EntradaCapteurs
SensoresAUTO OFF
MANUEL
Comande
AUTO OFF
MANUALIndicateur de
l'état
de la lumière
Indicador do
estado da luzFiltre
Filtro

Le must-have pour les salons de coiffure et les barbiers. Permet de se débarrasser des impuretés sans efforts. Muni d'un filtre HEPA qui garantit une filtration haute efficacité de l'air et de la technologie sans sac qui permet de faire des économies.

Deux modes d'utilisation : manuel ou automatique.

1.- Mode manuel : Positionner le tas de déchets devant les capteurs de l'appareil, actionner le bouton manuel et laisser aspirer.

2.- Mode automatique: balayez les cheveux, la poussière et les impuretés vers la base de l'unité : les capteurs infrarouges détecteront les déchets et actionneront l'aspirateur. L'appareil s'éteindra automatiquement lorsque toutes les impuretés auront été aspirées.

- Puissance nominale: 1400 W
- Modèle: VA001A-BK
- Tension nominale: 220-240V ~
- Fréquence: 50 / 60Hz
- Taille: (longueur x largeur x hauteur): 33 cm de long x 21 de large x 56,4 cm de haut
- Poids net: sur 5,1 kg
- Opération Bruit: ≥83db 1.5m
- Mode de travail automatique: Introduction de rayonnement infrarouge
- Aspiration (force de traction): ≥2,8 kg
- Capacité du réservoir à ordures: 2,7 L MAX
- Taille de cordon d'alimentation: 2m+

Aspirador de Cabelo última tecnologia. No modo manual, varre os escombros para a entrada na base da unidade, prima o botão de ativação manual e deixe que o HAIR VACUUM aspire os escombros através da entrada e na Coleção Bin.

1. O modo MANUAL terá uma duração de 5 segundos. Dependendo da quantidade de resíduos, pode ser necessário premir o botão de ativação manual mais de uma vez.

2. Quando se gira o indicador de controlo para a posição AUTO, varre os resíduos para a entrada na base da unidade e os sensores detetam os resíduos iniciando automaticamente um ciclo de aspiração que terminará assim que os sensores não detetarem mais resíduos.

- Potência nominal: 1400 W
- Modelo: VA001A-BK
- Tensão nominal: 220-240V ~
- Frequência: 50 / 60Hz
- Tamanho: (comprimento x largura x altura): 33 cm de comprimento x 21 de largura x 56,4 cm de altura
- Peso líquido: cerca de 5,1 kg
- Ruído de operação: ≥83db 1.5m
- Modo de trabalho automático: Introdução de radiação infravermelha
- Sucção (força de tensão): ≥2,8 kg
- Capacidade do tanque de lixo: 2.7L MAX
- Tamanho da exposição do cabo de energia: 2m

Stérilisateur uv professionnel en aluminium pour coiffure et esthétique Esterilizador eurostil u.V. Alumínio

u.m.vta: 1  1

REF. 03317

- Puissance: 8W
- Indiqué pour la stérilisation de petits ustensiles en plastique ou en métal, au moyen d'une ampoule uvc germicide.
- Ne pas utiliser pour stériliser s'autres objets
- L'ampoule dure environ 1300/1500 heures (= 1 an de fonctionnement).

- Potência: 8W
- Indicado para a esterilização de pequenos utensílios de plástico ou metal, através de uma lâmpada de raios uvc germicidas.
- Não utilizar com outros objetos não indicados.
- A lâmpada tem uma duração de cerca de 1300/1500 horas (= 1 ano de funcionamento).



Stérilisateur à la chaleur sèche sanity security Esterilizador calor seco sanity security

u.m.vta: 1  1

REF. 03011



- Puissance: 400W
- Température réglable entre 20°C et 200°C
- Mesures internes : 25 cm x 14,5 cm x 7 cm

- Potência: 400W
- Temperatura ajustável entre 20°C e 200°C
- Medidas internas: 25 cm x 14,5 cm x 7 cm



Stérilisateur EUROSTIL quartz

Esterilizador de quartzo EUROSTIL

u.m.vta: 1  6 

REF. 07013

- Puissance: 75W
- Tension: 220-240 V~
- Fréquence: 50/60Hz

- Potência: 75W
- Voltagem: 220 - 240 V~
- Frequência: 50/60 Hz



- Quartz
- Idéal pour les ustensiles métalliques, les ciseaux, etc.
- Comprend un sac avec des perles de quartz

- Quartzo
- Ideal para utensílios de metal, tesouras, etc
- Inclui bolsa com contas de quartzo



Pot de quartz sphères 500 g

Caixa de esferas de quartzo 500 g

u.m.vta: 1  12 

REF. 06619

Stériliser des outils métalliques pour la coiffure et l'esthétique.

Esterilizar ferramentas metálicas para cabeleireiro e estética.



Stérilisateur germicide GX4

Esterilizador germicida GX4



u.m.vta: 1 20



REF. 03009/59

- Puissance: 15W
- Température réglable entre 20°C et 200°C
- Ultra plat. Lumière germicide de haute qualité

- Potência: 15W
- Temperatura ajustável entre 20°C e 200°C
- Ultra plano. Luz germicida elevada qualidade



Pièces de rechange · Peças de reposição

u.m.vta: 1 1

REF. RE00891/01

Ampoule de rechange UV
Lâmpada de substituição UV



Stérilisateur UV professionnel en plastique

Esterilizador eurostil UV Plástico

u.m.vta: 1 1

REF. 06618



u.m.vta: 1 1

REF. RE06618/01

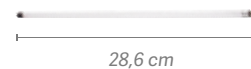

02

Rasoirs Navalhas

Rasoirs, lames, pen razor,
mousses à raser, gels...

Navalhas, lâminas, pen Razor,
espuma de barbear, gel de barbear...



Rasoir barbier REFINED
Navalha barbear REFINED

RAGNAR
 BARBER LINE

u.m.vta: 1  12

● Noir · Preto

REF.07163



● Argent · Prata

REF.07161



● Vieux cuivre · Cobre velho

REF.07162



- Mesure: 14,5 cm
- Pour lame demi-tranchant, ondulée
- ACIER J2 HAUTE QUALITÉ (420C)
- Logo marqué au laser

- Medida: 14,5 cm
- Para lâmina de meia borda
- AÇO J2 ELEVADA QUALIDADE (420C)
- Logo marcado com laser



RAGNAR
 BARBER LINE

Rasoir barbier PRECISE
Navalha barbear PRECISE

 u.m.vta: 1  100

REF.07124

- Idéal pour les retouches et le rasage
- Demi-lame cannelée
- Poignée noire
- Dimensions : 15 x 2,6 x 1,1 cm
- Platiné pour un meilleur rasage et des retouches plus précises

- Ideal para retoques e barbear
- Meia folha acanalada.
- Cabo preto
- Medidas: 15 x 2,6 x 1,1 cm
- Banhada a platina para um melhor barbear e retoque

RAGNAR rasoir manche noir métal
RAGNAR navalha punho metal preto

 u.m.vta: 1  25

REF.06986

- Rasoir très léger pour le rasage et les retouches de barbe et de cheveux avec manche métallique noir
- Lame demi-tranchant
- Aparelho de barbear muito leve para barbear e retoques de barba e cabelo com cabo preto metálico
- Lâmina de meia borda.



Rasoir à double lame classique. Lame de rasoir
Navalha clássica lâmina completa

Barber Line

u.m.vta: 1  12

REF.04929

u.m.vta: 1  7

REF.04550

u.m.vta: 1  6

REF.04933

Rasoir classique, à lame pleine et à double tranchant, un outil indispensable pour le barbier. Le rasoir a une poignée avec une texture en acier inoxydable pour une meilleure adhérence. Convient aux débutants. Prend en charge toutes les lames à double tranchant disponibles sur le marché.

- Lame pleine double bord

Navalha clássica, com lâmina cheia e gume duplo, uma ferramenta essencial para o barbeiro. A navalha tem uma alça com uma textura de aço inoxidável para uma melhor aderência. Adequado para iniciantes. Suporta qualquer lâmina de borda dupla disponível no mercado.

- Lâmina de borda dupla completa



Rasoir à Lame de rasoir classique
Navalha clássica lâmina completa

u.m.vta: 1  12

REF.04931

- Rasoir double lame classique avec manche en plastique. Coffret élégant inclus.
- Lame pleine double bord
- Máquina clássica de barbear com lâmina dupla e punho de plástico. Inclui uma elegante caixa.
- Lâmina de borda dupla completa



Barber Line

Rasoir barbier manche bois Navalha barbear punho de madeira

u.m.vta: 1  12**REF.04930**

- Lame demi-tranchant.
Interchangeable
- Lâmina de meia borda.
Trocável

u.m.vta: 1  12**REF. 04983**

Lame fabriquée au Japon, acier inoxydable 430, revêtement noir, manche en bois américain de couleur orange. Comprend un étui confortable en simili cuir.

- Lame demi-tranchant.

Peça com lâmina fabricada no Japão, aço inoxidável 430, revestimento em preto, cabo de madeira americana cor laranja. Inclui um cómodo estojo em pele ecológica.

- Lâmina de meia borda.



Rasoir barbier manche plastique Navalha barbear punho de plástico

u.m.vta: 1  10**REF.04898**

- Lame pleine double bord
- Lâmina de borda dupla completa



Le rasage peut devenir un acte de luxe et un certain sybaritisme avec Barber Line de Eurostil avec plus de 75 ans d'expérience dans le monde de la coiffure, nous avons créé cette ligne de produits pour l'homme moderne avec l'élégance du passé.

Barbear-se pode tornar-se todo um ato de luxo com Barber Line. Eurostil com mais de 75 anos de experiência no mundo da barbearia, criamos esta linha de produtos para o homem mais atual com a elegância do passado.

Rasoir barbiere lame manche plastique

Navalha barbear punho de plástico

u.m.vta: 1  10

REF.06057

- Lame demi-tranchant. Interchangeable
- Lâmina de meia borda. Trocável



Barber Line

Rasoir barbiere manche métal

Navalha barbear punho de plástico

u.m.vta: 1  10



REF.06058

- Lame demi-tranchant. Interchangeable
- Lâmina de meia borda. Trocável



Rasoir droit à double lame barber line

Navalha de barbear de duplo fio barber line

u.m.vta: 1  12 

REF.06647

- Idéal pour les retouches.
- Lame pleine double bord
- Para folha inteira e ideal Para retoques.
- Lâmina de borda dupla completa



Rasoir noir petit format

Navalha cor preto pequeno formato

u.m.vta: 1  12

REF.06435

- Idéal pour les retouches et pour les zones d'accès difficile
- Lame demi-tranchant. Interchangeable
- Ideal para retoque e para áreas de difícil acesso
- Lâmina de meia borda. Trocável



Rasoir retouches Navalha retoque

u.m.vta: 1  12

REF.06421

- Idéal pour les retouches et pour les zones d'accès difficile
- Lame demi-tranchant. Interchangeable

- Ideal para retoque e para áreas de difícil acesso
- Lâmina de meia borda. Trocável



Rasoir avec protecteur BARBER LINE Navalha com protetor BARBER LINE

u.m.vta: 1  12

REF.06417

- Avec caoutchouc
- Anneau rotatif sur la poignée pour plus de confort

- Com borracha
- Anel giratório no manípulo para maior conforto

REF.06419

*Barber Line*

REF.06420

- Sense caoutchouc
- Sem borracha



Pièces de rechange Recargas

REF. 07123



REF. 04388



REF. 04389





CONSEIL CONSELHO

Une fois le rasage terminé, lavez le rasoir à l'eau courante pour enlever les poils et la mousse de la lame. Séchez-le en le frottant avec un chiffon ou une serviette. Le rasage au rasoir présente de nombreux avantages, les coûts peu élevés liés au fait de ne pas acheter de lames de rechange. Se raser correctement procure souvent une plus grande douceur, un rasage de plus près et un rituel que beaucoup attendent avec impatience chaque matin.

Quando terminar de fazer a barba, lave a lâmina com água para remover o cabelo e a espuma da lâmina. Seque-o, esfregando-o com um pano ou uma toalha. Há muitos benefícios no barbear, os baixos custos de não comprar lâminas, o melhor controle das manobras de uma borda maior de uma lâmina através da pele. Barbear corretamente, muitas vezes, proporciona maior suavidade, um barbear e um ritual que muitos aguardam ansiosamente todas as manhãs.

RASOIR COUPE CHOUX captain cook NAVALHA DE BARBEAR captain cook

u.m.vta: 1 10

REF.04894

Rasoir coupe choux de précision ayant un manche en bois Captain Cook et avec lame entière, idéale pour le rasage. Coffret inclus. Lame pleine double bord

Navalha de barbear de precisão com punho de madeira Captain Cook com lâmina inteira. Inclui um estojo para sua correta conservação. Lâmina de borda dupla completa



u.m.vta: 1 12

REF.04932

Rasoir avec lame universelle interchangeable. Ergonomique grâce à la conception du manche qui le rend très confortable pour effectuer le rasage. Coffret inclus. Lame demi-tranchant

Navalha com lâmina trocável universal. Ergonómica graças ao design do punho que a torna muito cómoda para realizar barbeados. Inclui um elegante estojo. Lâmina de meia borda.



u.m.vta: 1 12

REF.04984

Rasoir coupe choux classique avec lame universelle interchangeable. Avec un manche en bois. Coffret simili cuir inclus. Lame demi-tranchant

Navalha clássica de barbear com lâmina trocável universal. Com punho de madeira, inclui um cómodo estojo em pele ecológica. Lâmina de meia borda.



u.m.vta: 1 12

REF.04985

Rasoir au Look avant-gardiste, noir avec lame universelle interchangeable. Large manche en bois noir. Coffret simili cuir inclus. Lame demi-tranchant

Navalha de Look vanguardista, de cor preta com lâmina trocável universal. Punho largo de madeira preta, inclui um cómodo estojo em pele ecológica. Lâmina de meia borda.





Rasoir noir petit format

Navalha cor preto pequeno formato

u.m.vta: 1  12

REF.06434

- Idéal pour les retouches et pour les zones d'accès difficile
- Lame demi-tranchant

- Ideal para retoque e para áreas de difícil acesso
- Lâmina de meia borda.



Rasoir coupe-choux petit format

Navalha de barbear pequeno formato

u.m.vta: 1  12

REF.06422

- Idéal pour les retouches et pour les zones d'accès difficile
- Lame demi-tranchant

- Ideal para retoque e para áreas de difícil acesso
- Lâmina de meia borda.



Rasoir avec protecteur et caoutchouc

Navalha com protetor e borracha

u.m.vta: 1  12

REF.06418

- Avec caoutchouc
- Anneau rotatif sur la poignée pour plus de confort

- Com borracha
- Anel giratório no manípulo para maior conforto



u.m.vta: 1  12

REF.06423

- Sense caoutchouc
- Sem borracha



Pièces de rechange
Recargas

REF. 07123



REF. 04388



REF. 04389



Rasoirs
Navalhas

u.m.vta: 1  12

REF.02124

- Rasoir à lame interchangeable.
- Acier inoxydable

- Navalha lâmina trocável.
- Aço inoxidável



Rasoir coupe-choux
Navalha de barbear

u.m.vta: 1  12

REF.00698

- Lame demi-tranchant. Interchangeable
- Acier inoxydable

- Lâmina de meia borda. Trocável.
- Aço inoxidável



Rasoir coupe-choux
Navalha de barbear

u.m.vta: 1  12

REF.00730

- Lame demi-tranchant. Interchangeable
- Avec peigne

- Lâmina de meia borda. Trocável.
- Com pente



Rasoir coupe- choux métallique
Navalha de barbear de metal

u.m.vta: 1  12

REF.04543

- Lame demi-tranchant. Interchangeable
- Lâmina de meia borda. Trocável.



u.m.vta: 1  12

REF.04544

- Lame demi-tranchant. Interchangeable
- Poignée en caoutchouc noir

- Lâmina de meia borda. Trocável.
- Punho de borracha preta



Distributeur de 20 lames
Dispensador 20 lâminas

Professional PB-20

u.m.vta: 1  10

REF.04391



Rasoirs FEATHER ARTIST ACS-RB
Navalhas FEATHER ARTIST ACS-RB

u.m.vta: 1  6

Artist ACS-RB
REF.04390



FEATHER

Rasoirs FEATHER ARTIST CLUB SS SCOTCH WOOD
Navalhas FEATHER ARTIST CLUB SS SCOTCH WOOD

u.m.vta: 1  6

Artist ACS-RSW
REF.04902



Rasoirs FEATHER DOUBLE EDGE POPULAR
Navalhas FEATHER DOUBLE EDGE POPULAR

u.m.vta: 1  12

REF.04392



u.m.vta: 20  20



REF.04393

Boîte de 10 lames
DOUBLE EDGE
Caixa 10 lâminas
DOUBLE EDGE





Carton de 10 boîtes de 100 demi-lames inoxydables pour un usage professionnel
Caixa com 10 caixinhas de 100 meias folhas inoxidáveis para uso profissional



u.m.vta: 1  10 

REF.07164

- Lame demi-tranchant
 - Coupe en acier inoxydable de qualité supérieure, lisse et précise
 - 10 boîtes x 100 lames
-
- Lâmina de meia borda.
 - Inoxidável premium, corte suave e preciso
 - 10 caixas x 100 lâminas



Conteneur pour lames usées
Contentor para depositar lâminas usadas

u.m.vta: 1  6 

REF.07258

De taille réduite, ce conteneur est idéal pour jeter les lames de rasoir utilisées par les coiffeurs et les barbiers.

- Couleur : noir
- Dimensions : base 7,5 x 7,5 cm partie supérieure 9 x 9 cm/ hauteur : 15 cm
- Capacité : Env. 1 l.

De tamanho reduzido, este contentor é ideal para colocar as lâminas de barbear utilizadas por cabeleireiros e barbeiros.

- Cor: preto
- Dimensões: base 7,5 x 7,5 cm parte superior 9 x 9 cm/ altura: 15 cm
- Capacidade: 1 l aprox.



Distributeur de 20 boîtes ELIOS**Dispensador 20 caixas ELIOS**u.m.vta: 1  50 **REF. 00994**

Lame de rasoir de référence pour les professionnels. Meilleure qualité de lame, meilleur affûtage et douceur d'utilisation.

Lâmina de barbear de referência para profissionais. Melhor qualidade da lâmina, melhor nitidez e uso suave.

- Lame de rasoir en acier inoxydable
- Acier suédois traditionnel de haute qualité
- Traité au platine pour un rasage parfait et sûr

- Lâmina de barbear inoxidável
- Aço tradicional sueco de alta qualidade
- Tratada com platina para um barbear perfeito e seguro



- 10 lames ondulées ELIOS
- 10 lâminas ranhuradas ELIOS

u.m.vta: 1  240 **REF.01351**



- 5 lames ondulées BIC
- 5 lâminas ranhuradas BIC

u.m.vta: 1  50 **REF.00995**



- 5 lames ondulées BOLZANO
- 5 lâminas ranhuradas BOLZANO

u.m.vta: 1  50 **REF. 06161**

- 5 lames canelées DERBY PREMIUM
- 5 lâminas com nervuras DERBY PREMIUM

u.m.vta: 1  50 **REF.02956**

- 5 lames ondulées
- 5 lâminas ranhuradas

u.m.vta: 1  80 **REF.02308**

- 10 lames "Supermax"
- 10 lâminas "Supermax"



Distributeur ASTRA 20 boîtes 5 feuilles

Dispensador ASTRA 20 caixas 5 folhas

u.m.vta: 1  100 

REF.07100

Lames de rasoir offrant un rasage de près et une grande douceur. Fabriquées en acier inoxydable et recouvertes de platine.

Boîte distributrice en carton contenant 20 packs de cinq lames emballées individuellement dans une enveloppe en papier paraffiné.



Lâminas com alta nitidez e ótima suavidade. Lâminas em aço inoxidável e revestimento de platina.

A caixa contém vinte caixas de papelão com cinco lâminas embrulhadas em papel de parafina em cada uma.



Boîte de 100 lames jetables

Caixa 100 lâminas descartáveis

u.m.vta: 1  50 

Derby Premium

REF. 06160



Derby Professional

REF. 02955



Boîte de lames

Dispensador de lâminas

u.m.vta: 1  50



REF.09101

- 10 lames Pièce de rechange haute performance pour rasoir 06192
- 10 lâminas troca navalha



Boîte distributrice 100 rasoirs jetables scellés RAGNAR

Caixa dispensadora 100 navalhas descartáveis seladas RAGNAR



u.m.vta: 1  12 

REF. 07439

Fabriqués en matière plastique de grande qualité. La lame en acier inoxydable suédois trempé, ainsi que son parfait tranchant assurent une qualité professionnelle dans chaque coupe. Léger, confortable et précis dans le rasage ou la coupe de cheveux. Le rasoir jetable RAGNAR est la garantie d'une hygiène maximale pour vos clients, puisqu'il est doté d'un scellement de sécurité facile à ouvrir.



Fabricadas em material plástico de primeira qualidade. As suas lâminas em aço inoxidável sueco, assim como o seu perfeito afiar, asseguram uma qualidade profissional em cada corte.

Leves, confortáveis de usar e precisas no rapar ou corte de cabelo. As navalhas de uma só utilização RAGNAR são a garantia de máxima higiene para o seu cliente, uma vez que dispõem de uma selagem de segurança de fácil abertura.

u.m.vta: 1  7 

REF. 02479

- 100 rasoirs jetables Pollié
- 100 navalhas descartáveis Pollié

u.m.vta: 1  12 



REF. 01951

- 100 rasoirs jetables
- 100 navalhas descartáveis



Boîte de rasoirs jetables

Caixa navalhas descartáveis

u.m.vta: 1  15 

REF. 03882

- 100 rasoirs Asorti (3 couleurs)
- Design ergonomique
- 100 navalhas surtidas (3 cores)
- Design ergonômico



Présentoir de rasoirs 03882

Dispensador para navalhas 03882

u.m.vta: 1  6

REF.04523

- Vide
- Vazio





Pen razor**Pen razor**u.m.vta: 1  20**REF.06154**

- Rasoir Pen + 20 lames
- Gillette barbear + 20 lâminas

Idéal pour dessiner sur les cheveux
Ideal para desenhar no cabelo

u.m.vta: 1  200**REF.06155**

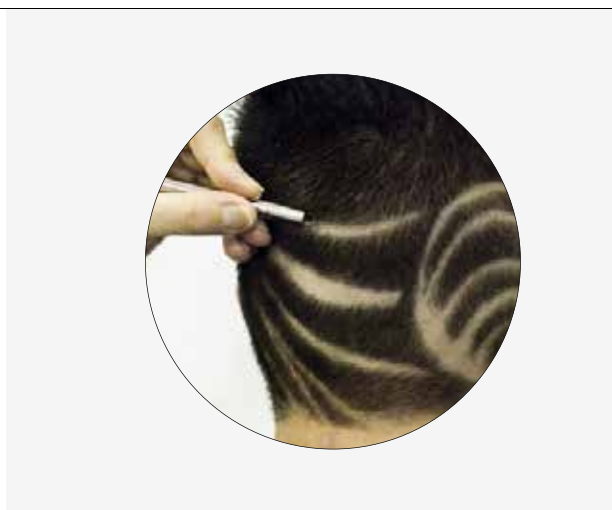
Idéal pour dessiner sur les cheveux
Ideal para desenhar no cabelo

**Mousse de rasage bic sensible****Espuma de barbear bic sensitive**u.m.vta: 6  6

250 ml

REF.03286

Mousse spécialement formulée pour les peaux sensibles. Sa formule à l'aloë vera, est connue pour ses effets apaisants. Aide à soulager les irritations causées par le rasage.

Espuma especialmente formulada para peles sensíveis. Sua fórmula com aloe vera é conhecida por seus efeitos calmantes. Ajuda a aliviar a irritação causada pelo barbear.





03

Ciseaux Tesouras

Ciseaux professionnels

Tesoura professional

Ciseaux BARBER LINE · BARBER LINE tesouras

Industrias Oriol présente sa gamme de ciseaux de haute qualité. Conçus pour favoriser le travail professionnel grâce à son bord de précision. Résistants à une grande usure et avec une finition en fabrication manuelle pour une qualité et une précision maximales.

PROPRIÉTÉS DU MATÉRIAU

• En acier inoxydable VG-10 de haute qualité, cet acier est un excellent acier japonais à haute teneur en carbone. Cet acier offre une plus grande résistance à la corrosion et une plus grande capacité à retenir le bord. Sa composition est la suivante: carbone: 1,05% à 1,5%, manganèse: 0,5%, chrome: 14,5% à 15,5%, vanadium: 0,1 à 0,3%, molybdène: 0,9% à 1,2% et cobalt: 1,5%. Ce mélange donne naissance à l'acier VG-10 et ses propriétés sont inhabituelles, ce qui conduit à une résistance élevée à l'usure et donc à une durabilité élevée. Il a une dureté allant jusqu'à 62 HRC.+

• Acier inoxydable martensitique 440C: C: 1,05% Mn: 0,45% Si: 0,40% Cr: 17,50% Mo: 0,70% S: <0,030%. Ce type d'acier à haute teneur en chrome et carbone est conçu pour offrir une résistance élevée à l'usure et à l'oxydation dans les environnements humides. Il atteint des duretés proches de 60 HRC et offre une bonne rétention des arêtes. Dureté: 59-61 HRC.

TAILLE DES CISEAUX

La taille des ciseaux est généralement mesurée en pouces. Les plus courts mesurent 4,5 pouces et les plus longs atteignent environ 8 pouces. Les ciseaux sont mesurés de la pointe au manche le plus long, à l'exclusion du support du doigt amovible ou permanent. La taille est choisie en fonction de la technique de coupe. Les ciseaux plus courts sont plus adaptés au travail de précision, les longs ciseaux sont plus adaptés au travail puissant. Les ciseaux de taille 5.0 "(13cm), 5.5" (14cm), 6.0 "(15cm) et 6.5" (16cm) sont les plus utilisés par les professionnels.

TYPES DE CISEAUX ET DE POIGNÉES

Les types disponibles pouvons trouver sont:

- Ciseaux coupe lame de rasoir: Il a deux lames droites, idéales pour effiler.
- Ciseaux vides ou sculptés: il sont composés d'une lame dentée et d'une autre pointue, idéale pour la coupe proportionnelle des cheveux.
- Ciseaux à micro-dents: avec une micro-scie sur une ou deux lames, idéaux pour que les cheveux ne glissent pas au moment de la coupe.
- Ciseaux aminçissants: les deux lames sont dentelées ou peignées, idéaux pour les cheveux clairsemés réduisant le volume ou marquant des couches sans perdre la longueur.

Industrias Oriol 1942, S.L. apresenta sua linha de tesouras de alta qualidade. Projetado para favorecer o trabalho profissional graças à sua borda de precisão. Resistente ao desgaste e com acabado a mão para máxima qualidade e precisão.

PROPRIEDADES DO MATERIAL

- Aço inoxidável VG-10 de alta qualidade. Este aço é um excelente aço japonês oferece maior resistência à corrosão. A sua composição é a seguinte: carbono: 1,05% - 1,5%, manganês: 0,5%, cromo: 14,5% - 15,5%, vanádio: 0,1 - 0,3%, molibdênio: 0,9% - 1,2%, cobalto: 1,5%. Esta mistura dá origem ao aço VG-10 e suas propriedades são incomuns, o que leva a uma alta resistência ao desgaste e, portanto, duradouro. Tem uma dureza de até 62 HRC.
- Aço inoxidável 440C: C: 1,05%, Mn: 0,45%, Si: 0,40%, Cr: 17,50%, Mo: 0,70%, S: <0,030%. Este tipo de aço, projetado para oferecer alta resistência ao desgaste e oxidação em ambientes úmidos. Atinge durezas próximas a 60 HRC e oferece boa retenção de borda. Dureza: 59-61 HRC.

TAMANHO DAS TESOURAS

O tamanho das tesouras é geralmente medido em polegadas. As curtas são 4,5 polegadas e as mais longas atingem até 8 polegadas. O tamanho é selecionado dependendo da técnica de corte. As tesouras mais curtas são mais adequadas para trabalhos detalhados. As tesouras de tamanho 5.0 "(13cm), 5.5" (14cm), 6.0 "(15cm) e 6.5" (16cm) são as mais utilizadas pelos profissionais.

TIPOS DE TESOURA

Os tipos que podemos encontrar são:

- Tesoura de corte de lâmina de barbear: Tem duas lâminas retas, ideais para cortes.
- Tesoura vazia ou esculpida: é composta de uma lâmina dentada e outra afiada, ideal para o esvaziamento proporcional do cabelo.
- Tesoura de corte com micro dentes: aquelas que possuem micro lamina serilladas, perfeitas para evitar que os cabelos deslizem para dentro no momento do corte.



4.5"

REF.06281

Poignée opposée, de base ou symétrique

Alça oposta, básica ou simétrica



5.5"

REF. 04629

Poignée semi-décalée ou semi-compensée

Alavanca Semi-Compensada ou Semi-Compensada



5.5"

REF. 04630

Poignée déportée
Alavanca compensada



Ciseaux coiffeur ROOSTER

Tesoura barbeiro ROOSTER

u.m.vta: 1  10

REF.06958

Coupe
Corte

6,5"



REF.06959

Coupe
Corte

7"



REF.06960

Sculpteur
Esculpir

6,5"



REF.06958/71

Coupe
Corte

6,5"



REF.06959/71

Coupe
Corte

7"



REF.06960/71

Sculpteur
Esculpir

6,5"



- Matériel: Acier japonais 440C
- Dureté: 59-61 HRC

- Material: Aço japonês 440C
- Dureza: 59-61 HRC

RAGNAR

BARBER LINE

Ciseaux coiffeur GLORIOUS

Tesoura barbeiro GLORIOUS

u.m.vta: 1  10

REF.06967

Coupe
Corte

6,5"



REF.06968

Coupe
Corte

7"



REF.06969

Sculpteur
Esculpir

6,5"



- Matériel: Acier japonais 440C
- Dureté: 59-61 HRC

- Material: Aço japonês 440C
- Dureza: 59-61 HRC



Ciseaux coiffeur LEFT DOMINANT (GAUCHERS)
Tesoura barbeiro LEFT DOMINANT (CANHOTO)

• Matériel: Acier japonais 440C
 • Dureté: 59-61 HRC

• Material: Aço japonês 440C
 • Dureza: 59-61 HRC

u.m.vta: 1  10

REF.06979

Coupe
Corte

6,5"

REF.06980

Coupe
Corte

7"

REF.06981

Sculpteur
Esculpir

6,5"

REF.06979/71

Coupe
Corte

6,5"

REF.06980/71

Coupe
Corte

7"

REF.06981/71

Sculpteur
Esculpir

6,5"





Ciseaux coiffure BLACK PEARL

Tesoura barbeiro BLACK PEARL

u.m.vta: 1  10

REF.06392

- Coupe
- Corte



REF.06393

- Sculpteur
- 32 dents obliques
- Esculpir
- 32 dentes oblíquos



5,5"



6"



- Matériel: Acier japonais 440C
- Corps: titane noir
- Vis: Réglage des doigts avec roulement à billes
- Dureté: 62HRC
- Poignée: décalée

- Material: Aço japonês 440C
- Corpo: titânio
- Parafuso: ajuste do dedo com rolamento de esferas
- Dureza: 62HRC
- Aperto: Offset

u.m.vta: 1  10

REF.04895

- Coupe
- Corte



REF.04896

- Sculpteur
- 50 dents
- Esculpir
- 50 dentes

7"



7"



- Matériel: SUS440C
- Dureté: 60HRC
- Bord: convexe

- Material: SUS440C
- Dureza: 60HRC
- Rebordo: convexo



Ciseaux coiffure CAPTAIN COOK Tesoura barbeiro CAPTAIN COOK

u.m.vta: 1  10

REF.06394

- Sculpteur
- 32 dents obliques
- Esculpir
- 32 dentes oblíquos



- Matériel: Acier japonais 440C
- Corps: titane noir
- Vis: Réglage des doigts avec roulement à billes
- Dureté: 62HRC
- Poignée: décalée

- Material: Aço japonês 440C
- Corpo: titânio
- Parafuso: ajuste do dedo com rolamento de esferas
- Dureza: 62HRC
- Aperto: Offset

Ciseaux coiffure BLACK RIPPER Tesoura barbeiro BLACK RIPPER

u.m.vta: 1  10

REF.06478

- Sculpteur
- Esculpir

REF.06479

- Sculpteur
- Esculpir

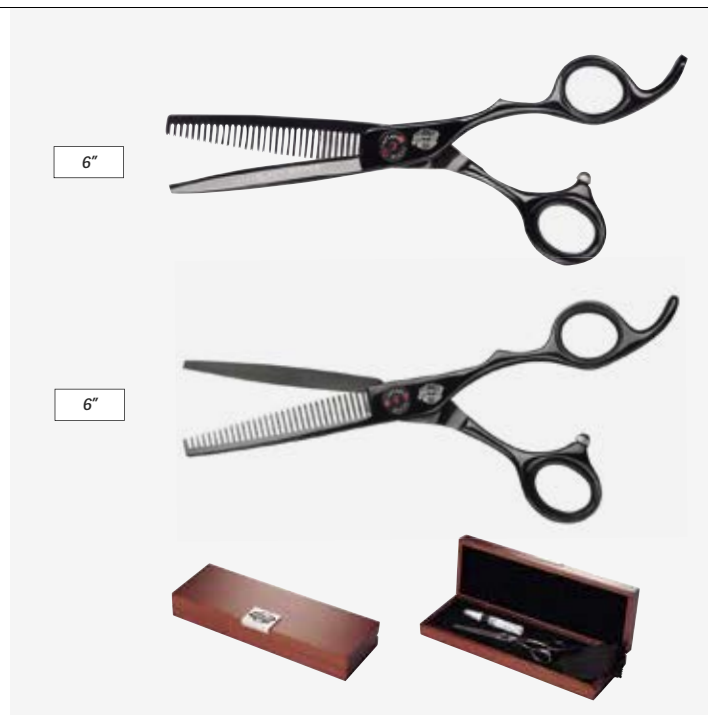

Acier japonais 440C. Ses lames fabriquées avec un degré d'affûtage supérieur. Idéales pour tous les types de coupes coupent les cheveux humides et secs. Ces ciseaux ont un design audacieux et moderne. 32 dents droites.

Aço Japonês 440C. Suas lâminas foram fabricadas com um grau superior de afiação, o que as torna ideais para todos os tipos de corte, com cabelos molhados ou secos. Estas tesouras são design arrojado e moderno, mas sem entrar em conflito com o estilo "old school". 32 dentes retos.



Ciseaux coiffeur **SILVER DIAMOND** Tesoura barbeiro **SILVER DIAMOND**

u.m.vta: 1  10

REF.04897

Coupe
Corte

8"



- Matériel: Acier japonais 440C
- Corps: titane
- Vis: Réglage des doigts avec roulement à billes
- Dureté: 62HRC
- Bord: Convexe
- Poignée: décalée

- Material: Aço japonês 440C
- Corpo: titânio
- Parafuso: ajuste do dedo com rolamento de esferas
- Dureza: 62HRC
- Rebordo: Convexo
- Aperto: Offset

Ciseaux coiffeur **BLACK QUEEN** Tesoura barbeiro **BLACK QUEEN**

u.m.vta: 1  10

REF.06961

- Avec poignée rotative
- Com alça rotativa

6,5"



- Matériel: Acier japonais 440C
- Dureté: 59-61 HRC

- Material: Aço japonês 440C
- Dureza: 59-61 HRC

Ciseaux coiffeur **LEGEND** Tesoura barbeiro **LEGEND**

u.m.vta: 1  10

REF.06962

Coupe
Corte

6,5"



REF.06963

Sculpteur
Esculpir

6,5"



- Matériel: Acier japonais 440C
- Dureté: 59-61 HRC

- Material: Aço japonês 440C
- Dureza: 59-61 HRC

Ciseaux coiffeur NEPTUNO

Tesoura barbeiro NEPTUNO

Barber Line

u.m.vta: 1  10 

REF. 04625 Coupe
Corte

REF. 04626 Sculpteur
Esculpir



- Acier 440
- Rasoir affûté
- Finition manuelle
- Grande dureté 59,61 HRC
- Vis de réglage
- Coffret individuel

- Aço 440
- Lamina afiada
- Acabamento manual
- Grande dureza 59.61 HRC
- Parafusos de ajuste
- Estojo individual

Ciseaux coiffeur BARBER LINE

Tesoura barbeiro BARBER LINE

u.m.vta: 1  10

REF.04899 • Coupe
• Corte

- Matériel: Acier 440C
- Dureté: 60HRC
- Bord: Convexe



- Material: Aço 440C
- Dureza: 60HRC
- Rebordo: Convexo

u.m.vta: 1  12

REF.06281 • Coupe
• Corte



• Idéal pour retoucher la barbe

• Ideal para retocar a barba

Ciseaux PIRATA

Tesoura PIRATA

u.m.vta: 1  10 

REF. 04630 • Coupe
• Corte



Ciseaux avec lames en acier WAVES

Tesoura corte aço WAVES

u.m.vta: 1  12

REF.04316

- Coupe
- Corte

6"



REF.04317

- Sculpteur
- Esculpir

5,75"



Ciseaux professionnels ERGO

Tesoura professional ERGO

u.m.vta: 1  12

REF.04314

- Coupe
- Corte

6"



REF.04315

- Sculpteur
- Esculpir

6"



Ciseaux avec lame noir et manche doré
Tesoura lamina afiada, cor preto, aperto dorado

u.m.vta: 1  12

REF.04499

- Coupe
- Corte

REF.04500

- Sculpteur
- Esculpir



Ciseaux avec lame de rasoir noire mate
Tesoura lamina afiada, cor preto mate

u.m.vta: 1  12

REF.04501

- Coupe
- Corte

REF.04502

- Sculpteur
- Esculpir



Ciseaux INITIATION

Tesouras INICIAÇÃO

u.m.vta: 1  12

REF.04359

- Coupe
- Corte



u.m.vta: 1  12

REF.04361

- Sculpteur
- Esculpir



Kit de coupe de cheveux pour étudiants

Kit corte estudantes

u.m.vta: 1  50

REF.04901

- 1 ciseaux de coupe
- 1 ciseaux sculpteur
- 1 rasoir coupe choux en métal
- 1 tesoura corte
- 1 tesoura esculpir
- 1 navalha metálica



Ciseaux professionnels spéciaux POUR GAUCHERS
Tesoura profissional especial PARA CANHOTOS

u.m.vta: 1  30

REF.02213

- Coupe
- Corte



Ciseaux professionnels spéciaux POUR GAUCHERS MATT
Tesoura profissional especial PARA CANHOTOS MATT

u.m.vta: 1  12

REF.04503

- Coupe
- Corte



REF.04504

- Sculpteur
- Esculpir

A collection of Barber Line grooming products is arranged on a light-colored wooden surface. In the upper left is a white cylindrical tin of talc with a green logo of a bearded man and the text 'Barber Line TALCO PERFUMADO'. To its right is a chrome safety razor and a shaving brush in a chrome holder. Below these are a black comb, a black neck brush, a black shaving brush, and a black hairbrush. Several Barber Line product boxes are scattered around, including one for a neck brush and another for a shaving brush. A white text box is centered over the products.

04

Brosses & blaireaux rasage Escovas & pincéis

*Balais à cou, blaireaux rasage,
talc coiffure...*

*Escovas, escovas de barbeiro,
talcos para barbeiro...*

Brosse à cou pour coiffeur avec réservoir de talc
Escova barbeiro com depósito talco

u.m.vta: 6  36



REF.01463

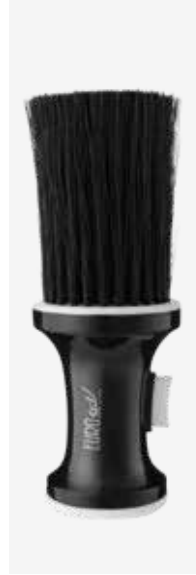

u.m.vta: 6  60

REF.01463/50



u.m.vta: 1  6 

REF. 00788





Brosse à cou pour coiffeur nylon
Escova barbeiro nylon

u.m.vta: 1  6 

REF. 03403





u.m.vta: 1  20 

REF. 01412





Brosse à cou pour coiffeur manche en bois
Escova barbeiro cabo de madeira

u.m.vta: 1  12 

REF. 00336



Blaireaux rasage**Pincéis**u.m.vta: 1  7 

Ø 21

REF. 07810



- Poils naturels
- Cheval, cheveux bruns

- Púas naturais
- Cavalo, cabelo castanho

REF. 04372

Ø 24



- Poils de poney

- Púas naturais.
- Cabelo de pônei

Ø 24

REF. 07811

Blaireaux rasage vintage**Pincéis vintage**u.m.vta: 1  20

S

REF.00644

- Les poils de la brosse sont faits de poils naturels de sanglier (bouillis avec du chlore pour clarifier la couleur)
- Poils de 50 mm env. de longueur
- Manche en bois et métal

- As Púas do pincel são de pêlo natural de porco (fervidas com cloro para aclarar a cor)

- Púas de 50 mm aprox. de largura
- Punho de madeira e metal

L

REF.00645



S





L

Bol pour savon à barbe**Bacia sabão para barba**u.m.vta: 1  4

REF.04255





Bouteille brosse Talc Spartal 280g
Frasco de escova de talco Spartal 280g

 u.m.vta: 1  6 

280 g

REF. 01293

RAGNAR Talc
Talco RAGNAR

 u.m.vta: 1  6 



200 g

REF. 06428

- Absorbe l'humidité.
- Maintient la peau fraîche et sèche.
- Soulage les irritations de la peau.
- Adoucit PAS d'allergènes et de parabens, testé dermatologiquement.
- **MODE D'EMPLOI:** Saupoudrer sur les mains ou sur le pinceau et appliquer autant de fois que nécessaire.

- *Absorve a humidade.*
- *Mantém a pele fresca e seca.*
- *Alivia a pele irritada.*
- *Suaviza.*
- *NÃO Allergenoss & Parabenos, dermatologicamente testados.*
- *MODO DE UTILIZAÇÃO: Aplicar nas mãos ou na escova e aplicar sempre que necessário.*

Boîte de talc parfumé
Lata de talco perfumado

 u.m.vta: 1  9 

300 g

REF. 06437

- Absorbe l'humidité
- Conserve la peau fraîche et sèche.
- Soulage et adoucit la peau irritée
- Sans parabens ni allergènes
- Packaging innovant et respectueux de l'environnement
- Au parfum masculin
- Conteneur innovant

- *Absorve a humidade*
- *Mantém a pele fresca e seca*
- *Alivia a pele irritada e suaviza*
- *Sem parabenos nem alérgenos*
- *Packaging novo e que respeita o meio ambiente*
- *Com perfume masculino*
- *Contentor inovador*



Plus
d'informations
 Mais
 informação

SCAN
ME!



Kit rasage Kit de barbear

u.m.vta: 1  24



REF.06177

Set de rasage classique pour hommes qui ne veulent pas renoncer au plaisir de se raser à l'ancienne. Il contient un rasoir pour un rasage précis, une brosse ergonomique qui apportera du confort et un bassin, outil indispensable pour tout coiffeur. Rasez à l'ancienne et obtenez un rasage parfait et précis en quelques minutes seulement.

kit de barbear clássico para homens gourmet que não querem perder o prazer de fazer a barba no estilo antigo. Contém uma lâmina de barbear precisa, uma escova ergonômica que irá proporcionar conforto e uma bacia, ferramenta indispensável para qualquer barbeiro. Raspe a moda antiga e obtenha um barbear perfeito e preciso em apenas alguns minutos.





Peigne spécial barbe Pente especial de barba

u.m.vta: 1  12 

REF.06176



Petite et grande brosse à barbe Ragnar Escova de barba Ragnar pequena e grande

u.m.vta: 1  20 

REF.07285



REF.07286

Brosses à cou RAGNAR en bois

Escovas cabeleireiro de madeira RAGNAR

u.m.vta: 1  14 

REF. 06070

RAGNAR brosse de coiffeur. Poils en nylon poli. Grande douceur et puissance de traînée. Idéal pour enlever les poils coupés du cou et de la nuque.

Escova de barbeiro RAGNAR. Púas de nylon polido. Grande suavidade e poder de arrasto. Ideal para remover o cabelo cortado do pescoço e da nuca.



Brosse TRITÓN

Escovas TRITÓN

u.m.vta: 1  12 

REF. 06076



La conception de cette brosse est conçue pour traîner les restes de cheveux qui restent sur la nuque après chaque coupe. La brosse TRITON est fabriquée à 100% avec du bois naturel alors que ses dents sont 100% synthétiques. Ses poils doux entraînent les restes de cheveux sans irriter.

O design deste pincel é projetado para arrastar os restos de cabelo que permanecem na nuca após cada corte. A escova TRITON é fabricada 100% com madeira natural, enquanto suas Púas são 100% sintéticos. Suas penas suaves arrastam os restos de cabelo sem arranhar.



Brosses à cou barbier pics polie

Escovas cabeleireiro picaretas

u.m.vta: 1  18 

REF.06116

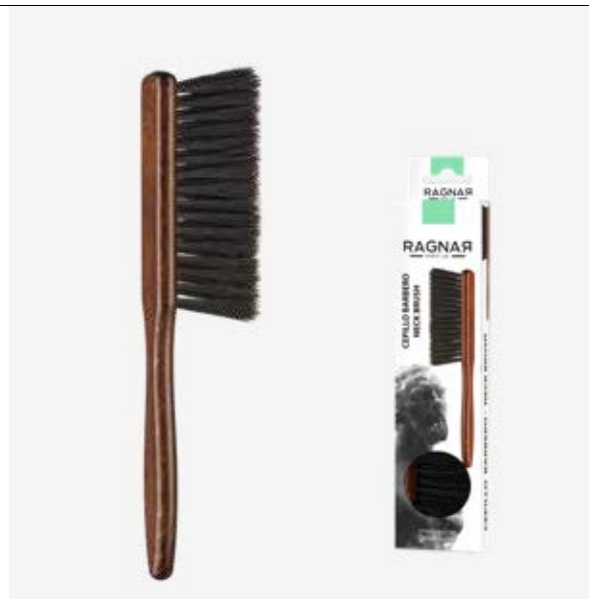

Brosse à bois du barbier RAGNAR. Avec des pics en nylon, qui offrent une grande douceur et une grande résistance. Idéal pour enlever les poils coupés du cou.

Escova de madeira cabeleireiro RAGNAR. Com Púas de nylon, que proporcionam grande suavidade e força de arrasto. Ideal para remover pêlos cortados do nuca e pescoço.



Brosse à barbe POSEIDON

Escova de barbeiro POSEIDON

u.m.vta: 1  12 

REF. 06078

Son design arrondi s'adapte parfaitement à la paume de la main permettant de peigner la barbe confortablement. La brosse POSEIDON est faite à 100% avec du bois naturel. Ses dents, 50% naturelles et 50% nylon, apportent cette touche de douceur.

Seu design arredondado adapta-se perfeitamente à palma da mão, permitindo pentear confortavelmente a barba. A escova POSEIDON é feita 100% com madeira natural. As Púas 50% naturais e 50% nylon, proporcionam toque natural.





10 cm



Brosse à barbe TALASA

Escova de barbeiro TALASA

u.m.vta: 1  12 

REF. 06073

Cette brosse de taille réduite sans poignée et de forme arrondie est parfaite pour les barbes courtes. Sa petite taille nous permet d'atteindre les zones difficiles à coiffer comme la zone de la moustache. La brosse TALASA est faite à 100% avec du bois naturel. Ses dents, 50% naturelles et 50% nylon, apportent cette touche de douceur.

Esta escova de tamanho reduzido sem punho e formato arredondado é perfeita para aquelas barbas curtas. Seu tamanho pequeno nos permite alcançar as áreas difíceis de pentear como a área do bigode. A escova TALASA é feita 100% com madeira natural. As Púas, 50% naturais e 50% nylon, proporcionam aquele toque natural.



8 cm



Brosse à barbe APOLO

Escova de barbeiro APOLO

u.m.vta: 1  12 

REF. 06077

La conception de cette brosse est conçue pour ces barbes denses et difficiles à peler. Sa large taille permet de larges zones de brossage et d'inégalité de la barbe. La brosse APOLO est 100% bois naturel. Ses dents 50% naturelles et 50% nylon apportent une touche de douceur que le choix naturel n'offre pas.

Este escova foi projetado para barbas densas e difíceis de escovar. A largura da escova permite escovar áreas grandes de barba. A escova APOLO é feita 100% com madeira natural. As Púas 50% natural e 50% nylon.





15 cm



Brosse à barbe OCEANO

Escova de barbeiro OCEANO

u.m.vta: 1  12 

REF. 06075

Le design de cette brosse est conçu pour le soin des cheveux et de la barbe. La brosse OCEANO est faite à 100% avec du bois naturel. Ses barbes 50% naturelles et 50% nylon offrent cette touche de douceur que la barbe naturelle n'offre pas.

O design deste pincel é projetado para o cuidado de cabelo e barba. A escova OCEANO é feita 100% com madeira natural. As Púas 50% natural e 50% nylon.





20 cm



Brosse à barbe NEREO

Escova de barbeo NEREO

u.m.vta: 1  12 

REF. 06072

Cette brosse de taille réduite munie d'une poignée est parfaite pour les barbes courtes. Sa poignée vous permet de peigner de petites zones comme la moustache. La brosse NEREO est fabriquée à 100% avec du bois naturel. Ses barbes 50% naturelles et 50% nylon procurent cette touche de douceur que la barbe naturelle n'offre pas.

Esta escova de tamanho reduzido é perfeita para as barbas curtas permite que penteie pequenas áreas como o bigode. A escova NEREO é feita 100% com madeira natural. As Púas 50% natural e 50%.

11,5 cm



Brosse GORGONAS pour les vêtements

Escova de roupa GORGONAS

u.m.vta: 1  12 

REF. 06074

Cette brosse a été conçue pour enlever les traces de poils emprisonnés dans les vêtements après la coupe. La brosse GORGONAS est faite à 100% avec du bois naturel et ses dents sont 100% nylon. Leurs dents dures entraînent les poils et la saleté, laissant les vêtements propres. Son contrôle ergonomique permet une tenue confortable de la brosse pendant le travail.

Esta escova foi projetada para remover os resíduos de cabelos presos nas roupas após o corte. A escova GORGONAS é feita 100% com madeira natural e as Púas são 100% nylon. São duras e arrastam os cabelos e a sujeira deixando as roupas limpas. Seu punho ergonômico permite uma fixação confortável da escova durante o trabalho.

27 cm



Brosse pour le dégradé

Escova fade

u.m.vta: 1  24 

REF. 04976

Brosse en plastique avec pointes en nylon doux, idéale pour les coupes "Fade"



Escova plástica com pontas de nylon macias, ideal para cortes "desbotados"

15 cm



Brosse à cou pour barbier

Escova pescoço barbeiro

u.m.vta: 4  40 

REF. 00501



- Manche en plastique
- Poils de nylon

- Punho de plástico
- Púas nylon



EUROSTIL
PROFESSIONAL

u.m.vta: 1  18 

REF. 00595



- Manche bois
- Poils de nylon

- Punho de madeira
- Púas nylon



Grande brosse à cou pour barbier

Escova barbeiro grande

u.m.vta: 1  14 

REF. 00306



- Manche en bois
- Poils de sanglier

- Punho de madeira
- Púas javali



Brosse plate pur sanglier

Escova plana puro de javali

u.m.vta: 1  12 



REF.00599

- Poils de sanglier naturel
- Cabelo natural de javali



Brosse EUROSTIL

Escova EUROSTIL

u.m.vta: 1  12 

REF. 00352



- Manche en bois
- Poils de sanglier naturel

- Punho de madeira
- Cabelo natural de javali



Brosse araignée courbée

Escova esqueleto curvo

u.m.vta: 12  96 

REF. 02195/50



- Poils de plastique avec ballon
- Púas de plástico com bola



Brosse araignée antistatique

Escovas esqueletos antiestático



| | | | |
|------------|---|----|---|
| u.m.vta: 1 |  | 12 |  |
|------------|---|----|---|



REF.00584

- Poils en nylon arrondis
- Púas de nylon com bola



Brosses araignée de deux

Escovas esqueletos duplos

| | | | |
|-------------|---|----|---|
| u.m.vta: 24 |  | 24 |  |
|-------------|---|----|---|



REF. 02182





REF. 02182/50



Brosse pour le dégradé

Escova fade

| | | | |
|------------|---|----|---|
| u.m.vta: 1 |  | 24 |  |
|------------|---|----|---|

REF. 04977

Brosse en plastique avec pointes en nylon doux, idéale pour les coupes "Fade"

Escova plástica com pontas de nylon macias, ideal para cortes "desbotados"





05



Peignes Pentes

Peignes Barber Line, peignes Captain Cook, peignes Eurostil, peignes Silkomb

Pentes Barber Line, pentes Captain Cook, pentes Eurostil, pentes Silkomb

Peigne de barbier coupe
Barber pente cupê

RAGNAR
BARBER LINE

u.m.vta: 12  72 



Noir
Preto

REF.07356



Ivoire
Marfim

REF.07356/82



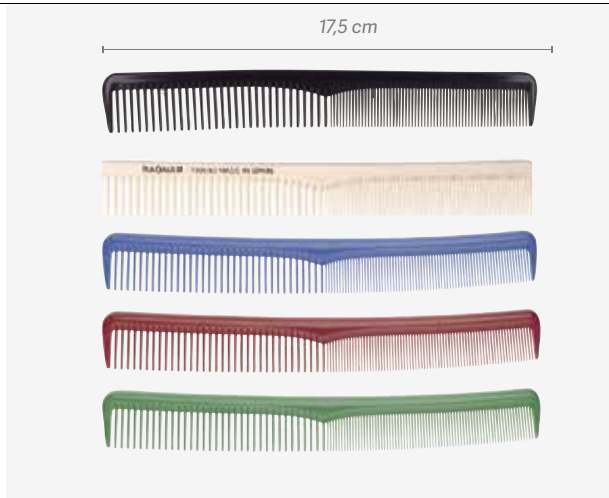

Classique
Clássico

REF.07356/98



Peigne de barbier
Pente de barbeiro

u.m.vta: 12  72 



Noir
Preto

REF.07355



Ivoire
Marfim



REF.07355/82

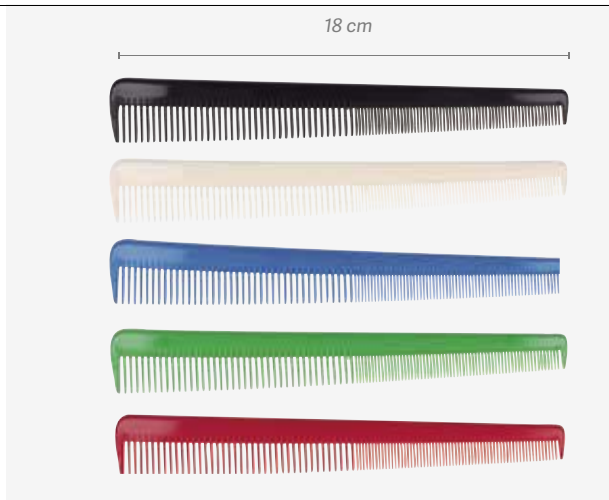

Classique
Clássico

REF.07355/98



u.m.vta: 12  72 



Noir
Preto

REF.07357



Ivoire
Marfim

REF.07357/82



Classique
Clássico

REF.07357/98





Peigne de barbier batteur

Barber pente batidor

RAGNAR
 BARBER LINE

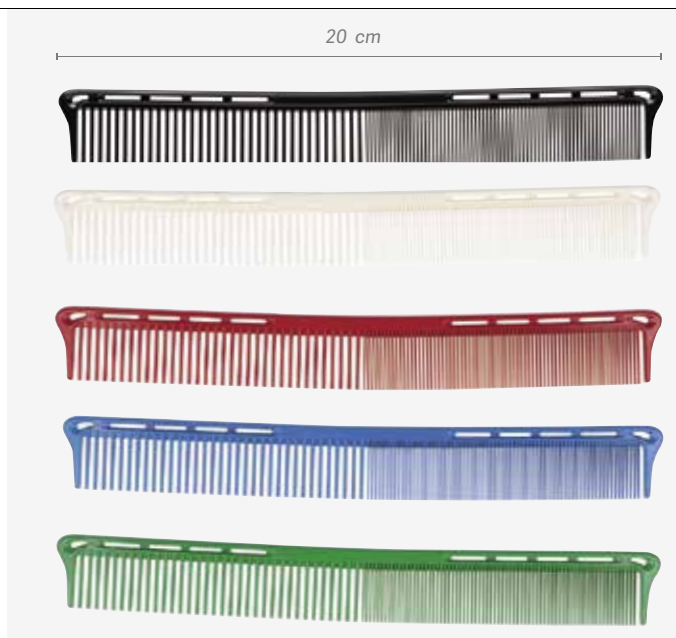

 u.m.vta: 12  72 

- | | | |
|---|--|---|
| <ul style="list-style-type: none"> • Noir • Preto | <ul style="list-style-type: none"> • Ivoire • Marfim | <ul style="list-style-type: none"> • Classique • Clássico |
| MOD. 04616 | MOD. 04616/82 | MOD. 04616/98 |
| REF.07358 | REF.07358/82 | REF.07358/98 |

 u.m.vta: 12  72 

- | | |
|------------|---|
| MOD. 00113 | <ul style="list-style-type: none"> • Nylon • Noir • Nylon • Preto |
| REF.07359 | |

- | | |
|------------|--|
| MOD. 00424 | <ul style="list-style-type: none"> • Renforcé • Noir • Reforçado • Preto |
| REF.07360 | |

 u.m.vta: 12  48 



- | | |
|------------|---|
| MOD. 00454 | <ul style="list-style-type: none"> • Droit • Noir • Recto • Preto |
| REF.07361 | |

- | | |
|------------|---|
| MOD. 00455 | <ul style="list-style-type: none"> • Mèches • Noir • Mechas • Preto |
| REF.07362 | |



Peigne carbone RAGNAR
Pente carbono RAGNAR

RAGNAR
 BARBER LINE

u.m.vta: 12  72 

MOD. 02216

- Batteur de coupe
- Batidor corte

REF.07367





MOD. 02215

- Spécial
- Especial

REF.07368

Peigne barbier coupe spécial machine
Pente de barbeiro de corte especial

u.m.vta: 12  60 

MOD. 02183

- Peigne de coupe spécial professionnel
- Pente corte especial máquina professional

REF.07363



MOD. 06802

REF.07364



MOD. 06802/82

- Peigne de coupe spécial professionnel
- Pente corte especial máquina professional

REF.07364/82

Peigne barbier afro

Pente de barbeiro dentes largos

u.m.vta: 12  60 



MOD. 00419/50 • Noir
• Preto

REF.07365/50



Peigne mèches

Pente mechas

u.m.vta: 12  48 

MOD. 00409/50 • Noir
• Preto

REF.07366/50

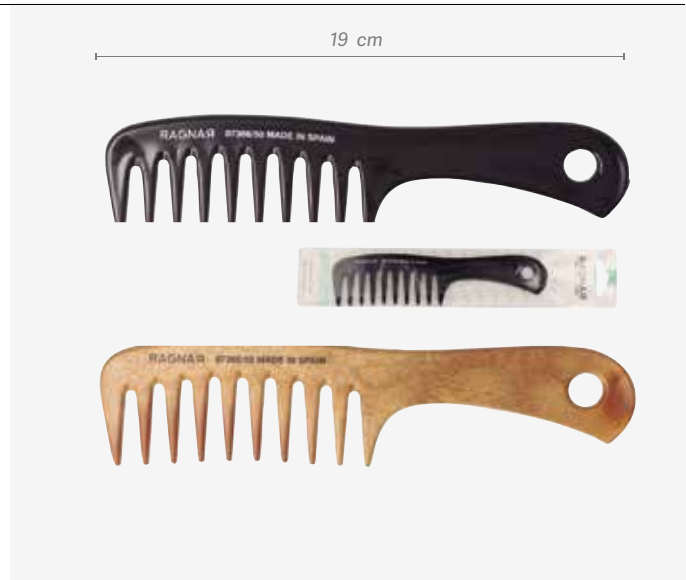



MOD. 00409 • Bois
• Madeira

REF.07366/55

Peigne mèches

Pente mechas

u.m.vta: 12  48 

REF.07602 • Double dent
• Dupla fileira de dentes



Ligne de peignes CAPTAIN COOK
Linha de pente CAPTAIN COOK



| | | |
|-------------|----|--|
| u.m.vta: 12 | 72 | |
|-------------|----|--|

REF. 04981

- Carbone
- Carbono

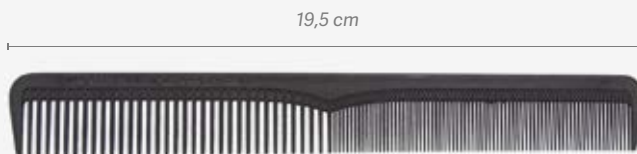

REF.07441

- Noir
- Preto

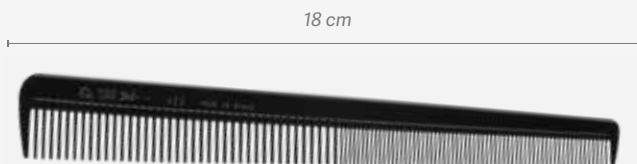

REF.07441/82

- Ivoire
- Marfim



| | | |
|-------------|----|--|
| u.m.vta: 12 | 72 | |
|-------------|----|--|

REF.07442

- Negro
- Black

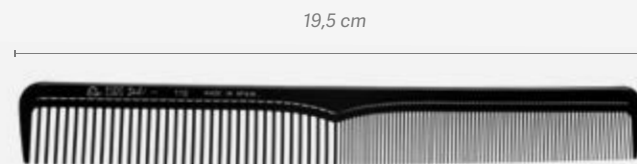



REF.07442/82

- Ivoire
- Marfim



Ligne de peignes CAPTAIN COOK
Linha de pente CAPTAIN COOK



u.m.vta: 12  60 



REF.07443

20,5 cm



REF.07443/82



- Mèches / Noir
- Mechas - Preto

u.m.vta: 12  48 

REF.07444

19 cm



u.m.vta: 12  60 

REF.07474

NEW



REF.07474/82





Peigne bois barbe moustache
Pente maderá barba-bigote

u.m.vta: 12 60

REF.04548

- À larges
- Largo



u.m.vta: 12 96

REF.04549

- Avec manche
- Com punho



Peigne coquille pour barbe - moustache
Pente concha barba - bigode

u.m.vta: 12 120

REF.04546

- À long manche
- Cabo largo



REF.04547



u.m.vta: 12 96

REF.04545

- Pliage
- Dobrável



Peigne batteur EUROSTIL
Pente batidor EUROSTIL



u.m.vta: 12 72



REF. 00115

- Spécial
- Especial

17,5 cm



REF. 00442

- Spécial
- Especial

17,5 cm

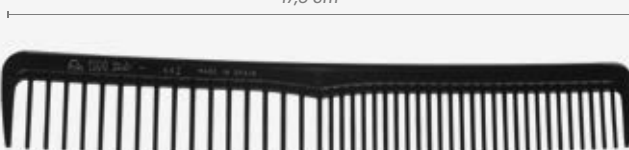

REF. 00441

- Spécial
- Especial

17,5 cm

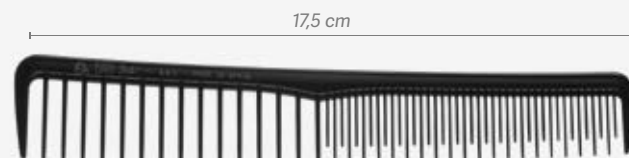

REF. 00424

- Spécial
- Especial

18,5 cm



REF. 00116

- Grand
- Grande

19,5 cm

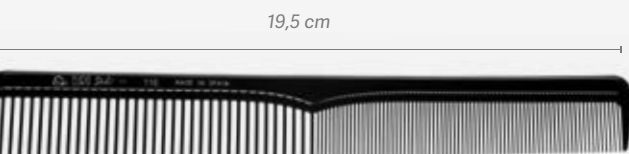

REF. 01470

- Spécial
- Especial

21,5 cm

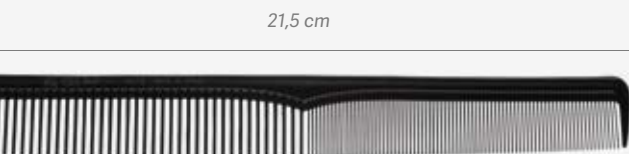

Peigne batteur spécial
Pente batidor especial



REF. 00422





REF. 00422/58

18 cm



Peignes carbone Pentes carbono

| | | |
|-------------|--|---|
| u.m.vta: 12 |  72 |  |
|-------------|--|---|

REF. 02186

- Batteur de coupe
- Batidor corte

17,5 cm

**REF. 02214**

- Batteur spécial à dents
- Batidor dente especial

17,5 cm

**REF. 02215**

- Spécial de coiffure
- Especial cabeleireiro



18 cm

**REF. 02216**

- Batteur de coupe
- Batidor corte

19,5 cm





| | | |
|-------------|--|---|
| u.m.vta: 12 |  48 |  |
|-------------|--|---|

REF. 02188

- Modèle RECTO
- Mmod. RECTO

19,5 cm



| | | |
|-------------|--|---|
| u.m.vta: 12 |  72 |  |
|-------------|--|---|

REF. 02187



- Spécial à dents
- Dentição especia

20,5 cm



Peignes professionnels SILKOMB
Pente professional SILKOMB

SILKOMB™

u.m.vta: 1  50 

PRO-10

REF. 01520

24 cm

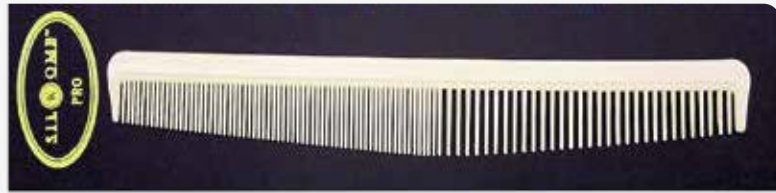

PRO-40

REF. 01524

23 cm

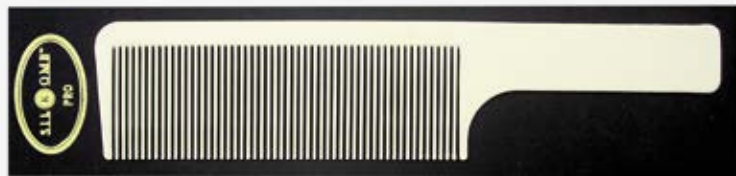

PRO-50

REF. 01525

22,5 cm



PRO-20

REF. 01522

19 cm



PRO-30

REF. 01523

19 cm





PRO-11

REF. 01521

17,5 cm



Peigne avec niveaux
Pente com níveis

u.m.vta: 1  120 



REF. 04349



Le peigne avec niveaux permet de faire une coupe ou une mise à l'échelle dans une ligne droite parfaite grâce à ses 3 niveaux

O pente com níveis permite realizar um corte ou escalado em linha reta perfeita graças aos seus 3 níveis

Brosse de nettoyage peigne
Escova de limpeza pentes

u.m.vta: 1  100 

REF. 00600



06

Cosmétique Cosméticos

Cosmétique capillaire cosmétique barbe, fixations cosmétique

Cosméticos capilares, cosméticos para barba, artigos de fixação cosmética

TASSEL
PROFESSIONAL HAIR COSMETICS

¡Gana seguridad!

Disimula la calvicie con
Fibras capilares Tassel

Win security!

Conceal baldness with
Tassel hair fibers

NEGRO - BLACK

CASTAÑO OSCURO
DARK CHESTNUT

CASTAÑO - CHESTNUT

CASTAÑO CLARO
LIGHT CHESTNUT

RUBIO OSCURO
LIGHT BLONDE

RUBIO CLARO
LIGHT BLONDE

GRIS CLARO - LIGHT GREY

GRIS OSCURO - DARK GREY

GRIS - GREY

GRIS CLARO - LIGHT GREY

GRIS OSCURO - DARK GREY

GRIS - GREY

GRIS CLARO - LIGHT GREY

GRIS OSCURO - DARK GREY

GRIS - GREY

GRIS CLARO - LIGHT GREY

GRIS OSCURO - DARK GREY

GRIS - GREY

GRIS CLARO - LIGHT GREY

GRIS OSCURO - DARK GREY

GRIS - GREY

GRIS CLARO - LIGHT GREY

GRIS OSCURO - DARK GREY

GRIS - GREY

GRIS CLARO - LIGHT GREY

GRIS OSCURO - DARK GREY

GRIS - GREY

GRIS CLARO - LIGHT GREY

GRIS OSCURO - DARK GREY

GRIS - GREY

GRIS CLARO - LIGHT GREY

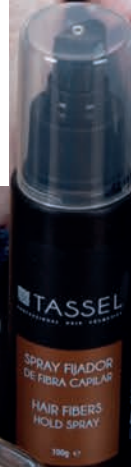

Retouche racines Ragnar 75 ml pour cheveux et barbe
Retoca-raíces Ragnar 75 ml para cabelo e barba

u.m.vta: 1

12



REF. 07475/50



- Noir
- Preto

REF. 07475/65



- Châtain clair
- Castanho claro

REF. 07475/67



- Brun foncé
- Castanho escuro

NEW

- Coloration temporaire en spray.
- Elle couvre les racines et les cheveux blanc instantanément.
- *Coloração temporária em spray.*
- *Cobre raízes e cabelos brancos num instante.*

Présentoir retouche-racines Ragnar
Expositor retoca-raíces Ragna

u.m.vta: 1

1

REF. 07582

Vide
Vazio
REF. 07582/01





NEW

Shampooing rafraîchissant Champô refrescante

u.m.vta: 1  4



250 ml PH 5.5

REF. 04963

u.m.vta: 1  2 

500 ml PH 5.5

REF. 07374

u.m.vta: 1  6 

1L PH 5.5

REF. 07375



Régulateur de cuir chevelu

Avec des tensioactifs doux et un pouvoir mouillant élevé, abaissant la tension superficielle de l'eau. Pour ses actifs, il possède des propriétés de conditionnement des cheveux pour faciliter le peignage, apporte de l'humidité pour surmonter la sensation de sécheresse et de fragilité, contrôle la production de cellules mortes dans le cuir chevelu, exerce une activité antibactérienne et antifongique. Idéal pour les cheveux et les cuirs chevelus sensibles.

Regulador do couro cabeludo



Com surfactantes suaves, alto poder de umedecimento, que reduz a tensão superficial da água. Por seus ativos, possui propriedades condicionantes para facilitar o penteado, proporciona umidade para superar a sensação de secura e fragilidade, controla a produção de células mortas no couro cabeludo, exerce atividade antibacteriana e antifúngica. Ideal para cabelos e couro cabeludo sensíveis.

Shampooing pour cheveux gris Champô cabelos grisalhos

u.m.vta: 1  4



250 ml PH 5.5

REF. 04965

u.m.vta: 1  2 

500 ml PH 5.5

REF. 07376

u.m.vta: 1  6 

1L PH 5.5

REF. 07377







Pour les cheveux gris

Avec des tensioactifs doux et un pouvoir mouillant élevé, abaissant la tension superficielle de l'eau. Pour ses actifs conditionne les cheveux pour les rendre plus faciles à coiffer et avec des pigments d'origine végétale qui empêchent le changement de couleur dans les cheveux gris rallumant l'éclat. Spécial pour les cheveux gris, prévient et couvre le ton jaunâtre.

Para cabelos grisalhos

Com surfactantes suaves, alto poder de umedecimento, que reduz a tensão superficial da água. Por seus ativos condiciona o cabelo para facilitar o pentear, com pigmentos de origem vegetal que impedem a mudança de cor nos cabelos grisalhos reacendendo o brilho. Especial para cabelos grisalhos, previne e cobre o tom amarelado.

Shampooing rafraîchissant Champô refrescante

u.m.vta: 1  2  u.m.vta: 1  6 

500 ml PH 5.5 1L PH 5.5

REF. 07370

REF. 07371

Particulièrement indiqué pour prévenir et combattre la chute des cheveux, stimulant le cuir chevelu et apportant une vitalité renouvelée. Il réduit le sébum, redonnant aux cheveux leur éclat naturel.

Especialmente indicado para prevenir e combater a queda de cabelo, estimula o couro cabeludo dando-lhe uma nova vitalidade. Reduz o sebo devolvendo ao cabelo o seu brilho natural.



Crème adoucissante Condicionador

u.m.vta: 1  4

250 ml PH 5.5

REF. 04870



u.m.vta: 1  2  u.m.vta: 1  6 

500 ml PH 5.5 1L PH 5.5

REF. 07372



REF. 07373

Supplément de shampooing. Elle incorpore les propriétés rafraîchissantes et stimulantes du cuir chevelu, restaurant son hydratation et son éclat naturel.

Complementa o champô. Contém propriedades refrescantes e estimulantes do couro cabeludo, devolvendo a sua hidratação e brilho natural.



Pommade coiffante et fixation douce
Pomada de penteado de fixação suave



u.m.vta: 1  6 

200 ml

100 ml

REF. 04867

REF.06232

u.m.vta: 1  16 

50 ml



REF.06233



Idéale pour les styles exigeants qui veulent avoir un aspect parfait. Elle vous donnera de la brillance et une fixation souple et sans laisser de résidus. À base d'eau, qui apporte douceur et hydratation aux cheveux.

Idéal para estilos exigentes que pretendam um aspeto perfeito. Dará brilho e uma fixação suave e flexível sem deixar resíduos. À base de água, o que dá uma suavidade e hidratação ao cabelo.

Pommade coiffante et fixation moyenne
Pomada de penteado de fixação média



u.m.vta: 1  6 

200 ml

100 ml

REF. 06229

REF.06230

u.m.vta: 1  16 

50 ml



REF.06231



Application facile de cire à la crème pour maintenir et définir la coiffure désirée. Avec des cires naturelles et du beurre de karité qui protègent et soignent les cheveux. Fini mat naturel pour tout type de coiffure.

Cera pomada fácil aplicação para manter e definir o penteado desejado. Com ceras naturais e manteiga de karité que protegem e cuidam dos cabelos. Fixação mate natural para qualquer tipo de penteado.

Pommade coiffante et fixation forte Pomada de penteado de fixação forte

u.m.vta: 1  6 

200 ml

100 ml

REF. 04866

REF.06236

u.m.vta: 1  16 

50 ml

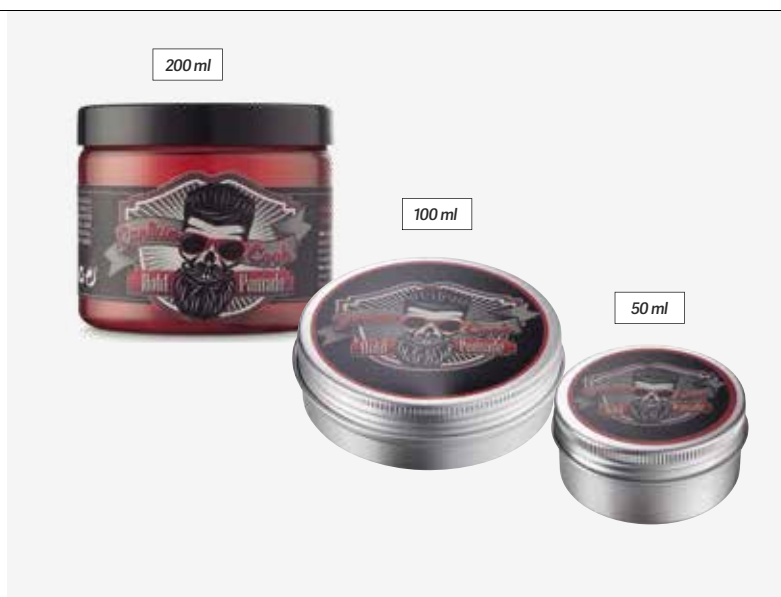

REF.06237



Elle fournit de la brillance et une forte fixation tout en laissant les cheveux souples, faciles à enlever sans laisser de résidus. À base d'eau, qui apporte douceur et hydratation à la finition.

Dá brilho e uma fixação forte, mas deixando o cabelo flexível, de fácil eliminação sem deixar resíduos. À base de água, o que dá uma suavidade e hidratação ao cabelo.

Pommade coiffante mate et fixation Rubber Matt Pomada de penteado, fixação Rubber Matt



u.m.vta: 1  6 

200 ml

100 ml

REF. 04868

REF.06234

u.m.vta: 1  16 

50 ml



REF.06235



Pommade coiffante Mate et Fixation RUBBER MATE. Elle permet de donner forme et volume aux cheveux en obtenant une coiffure durable. Séchage rapide et finition mate. Elle ne laisse pas de résidus. Grâce à sa composition riche en cires naturelles elle apporte douceur et protection aux cheveux

Pomada de penteado fixação mate RUBBER MATE. Permite dar forma e volume ao cabelo conseguindo um penteado duradouro. De secagem rápida e fixação mate. Não deixa resíduos. A sua composição rica em ceras naturais dá suavidade e proteção ao cabelo.

Cire fibreuse modelante fixation forte Spider Gum Cera fibrosa modelagem fixação forte Spider Gum



u.m.vta: 1  6 

200 ml

100 ml

REF. 06677

REF.06678

u.m.vta: 1  16 

50 ml



REF.06679



Cire fibreuse pour modeler et texturiser les cheveux, à fixation forte, longue durée et facile à éliminer.
Mode d'application: prendre une petite quantité de produit entre les doigts, la chauffer en frictionnant les mains pour activer les fibres et appliquer sur les cheveux pour donner la forme souhaitée.

Cera fibrosa para moldar e texturizar o cabelo de fixação forte, longa duração e fácil de eliminar.
Modo de aplicação: aplique uma pequena quantidade de produto entre os dedos, aquecê-l com a fricção das mãos para ativar as fibras e aplicar sobre o cabelo, dando-lhe a forma desejada.

Fixation à effet sec gravity zero Fixação a seco gravity zero

u.m.vta: 1  10 

125 ml



REF. 04961

Gravity Zero: Grâce à sa composition, il laisse sur les cheveux un film invisible d'effet sec avec un grand volume et un pouvoir hydratant. Idéal pour tout type de cheveux offrant une luminosité. Puissant même avec une humidité et une température élevées. Vaporiser directement sur les cheveux et peigner selon le style désiré.

Gravity Zero: Graças à sua composição, deixa no cabelo uma película invisível de efeito seco com grande volume e poder hidratante. Ideal para qualquer tipo de cabelo, proporcionando brilho. Poderoso mesmo com alta umidade e temperatura. Pulverize diretamente sobre o cabelo e penteie de acordo com o estilo desejado.



Laque professionnelle forte Laca professional forte

u.m.vta: 1  12 

300 ml

REF.07129

Elle apporte aux cheveux une excellente fixation et une brillance naturelle tout en les protégeant des agents extérieurs tels que le vent, l'humidité, etc.
Elle permet de conserver une coiffure intacte toute la journée. Effet Long Lasting. Elle s'élimine facilement avec un léger brossage. Elle renforce la fibre capillaire.

*Proporciona ao seu cabelo uma excelente fixação e um brilho natural, ao mesmo tempo que o protege de agentes externos como o vento, humidade, etc.
Mantém o penteado perfeito durante todo o dia. Efeito Long lasting. Elimina-se facilmente com uma leve escovagem. Fortalece a fibra capilar.*



Laque écologique Laca ecologica

u.m.vta: 1  24 

300 ml

REF.07113

Captain Cook Hair Spray est idéal pour les structurés. Il respecte le cheveu grâce à l'action de la provitamine B5. Sa diffusion micro - fine ne surcharge pas les cheveux et il s'élimine facilement au brossage.

O capitão Cook Spray para cabelos é ideal para trabalhos estruturados, respeita os cabelos graças à ação da provitamina B5. Sua difusão por micro-difusão não sobrecarrega o cabelo e é facilmente removida ao escovar.



Gel boucles CAPTAIN COOK CAPTAIN COOK curl gel

u.m.vta: 1  24 

250 ml

REF.07378

La crème définition de boucles a été spécialement conçue pour définir simplement et facilement les boucles et les ondulations des cheveux. Les protéines de blé apportent hydratation et brillance, et évitent les frisottis. Créez votre look avec vos doigts. Laisser sécher à l'air ou utiliser un diffuseur pour une définition optimale des boucles.

Bienfaits

- Définition des boucles
- Hydratation maximale
- Volume

Creme que define e amplifica os cachos dando um aspecto natural. Enriquecido com Proteínas do Trigo.

O creme de definição de cachos é especialmente formulado para desenhar cachos e ondas nos cabelos de forma fácil e confortável. As proteínas do trigo proporcionam hidratação e brilho, evitando o frizz. Modele seu visual com os dedos. Deixe secar ao ar ou difundir para uma definição ideal dos cachos.



Benefícios

- Definição de caracóis
- Máxima Hidratação
- Volume



Poudre volumisante Gravity Powder

Pó volumizante Gravity Powder



u.m.vta: 1  15 

10 g

- Avec pulvérisateur
- Com pulverizador

REF. 06473

Meilleur prix
produit de l'année
Premio melhor
produto do ano

u.m.vta: 1  20 

20 g

REF. 04962



Gravity Powder: poudre matifiante à texture ultra légère. Il apporte un grand volume aux cheveux, avec son application facile en massant au minimum la racine des cheveux. Idéal pour fixer des coiffures très structurées. Effet mat doux Grâce à ses actifs, il ne laisse pas de cheveux gras, même dans les cheveux sujets, contribuant à absorber l'excès de séborrhée. Sans control. Fixation durable

Gravity Powder: pó matificante de textura ultra leve. Traz grande volume ao cabelo, com sua fácil aplicação massageando minimamente a raiz do cabelo. Ideal para a fixação de penteados muito estruturados. Efeito fosco suave Graças aos seus ativos, ele não deixa os cabelos oleosos, mesmo nos cabelos propensos, ajudando a absorver o excesso de seborreia. Fixação durável

Shampooing au Bourbon

Champô Bourbon

u.m.vta: 1  2

5 L

REF. 07096

Captain Cook Hair Spray est idéal pour les structurés. Il respecte le cheveu grâce à l'action de la provitamine B5. Sa diffusion micro-fine ne surcharge pas les cheveux et il s'élimine facilement au brossage.

O capitão Cook Spray para cabelos é ideal para trabalhos estruturados, respeita os cabelos graças à ação da provitamina B5. Sua difusão por micro-difusão não sobrecarrega o cabelo e é facilmente removida ao escovar.



Pack barbe

Pack barba

u.m.vta: 1  4

REF. 06668

Il contient un shampooing pour barbe 250 ml + huile à barbe 30 ml + cire à barbe 50 ml.

Inclui shampoo barba 250 ml + óleo para barba 30 ml + cera para barba 50 ml.



Pack cheveux

Pack cabelo

u.m.vta: 1  4

REF. 06669

Il contient un shampooing rafraîchissant 250 ml + Gravity Powder 20 g + cire mate 50 ml.

Inclui shampoo refrescante 250 ml + Gravity Powder 20 g + cera mate 50 ml.



u.m.vta: 1  10

REF. 07079

Besoin de vide
Precisa vazia



Huile avant rasage Óleo pré-barbear

u.m.vta: 1  6 

30 ml



REF. 04860



Pour une expérience de rasage agréable. Produit spécialement conçu pour traiter la peau avant le rasage. Contient des actifs rafraîchissants qui aident à faire glisser la lame en toute sécurité.

Para una experiencia agradable de barbear. Producto especialmente concebido para tratamiento da pele antes de barberar.

Huile pour la barbe Óleo para barba

u.m.vta: 1  6 

30 ml



REF. 04861



Barbe saine et maniable. Mélange d'huiles naturelles qui nourrissent et hydratent les cheveux de la barbe en les aidant à rester en bonne santé et à les gérer. Pas gras

Barba saudável e Maleável. Mistura de Óleos Naturais que nutrem e hidratam a barba ajudando-a a manter saudável e maleável. Não oleoso.

Cire à barbe Cera para barba

u.m.vta: 1  6 

50 ml



REF. 04865



Dominez votre barbe. Forte concentration d'actifs naturels tels que l'huile d'argan et la rose musquée, qui protègent et nourrissent les cheveux en profondeur sans donner de sensation de graisse.

Domina a tua barba. Alta concentração de ativos naturais como Óleo de Argão e Rosa Mosqueta, que protegem e nutrem o pêlo em profundidade sem deixar nenhuma sensação de oleosidade.

Shampooing pour barbe Champô para barba

u.m.vta: 1  6 

250 ml

PH 5.5



REF. 04862



Nettoyage en profondeur. Savon nettoyant aux propriétés hydratantes et adoucissantes. Il produit une mousse dense qui élimine les impuretés.

Limpeza Profunda. Sabão de limpeza com propriedades hidratantes e suavizantes. Produz uma espuma densa, que arrasta as impurezas.

Crème de barbear Crème de rasage

u.m.vta: 1  6 

250 ml

PH 5.5



REF. 04863



Le rasage est facile ... Formulée avec des ingrédients actifs doux et hydratants pour la protection de la peau. Spécialement conçue pour ouvrir les pores, hydrater la peau et adoucir la barbe pour faciliter le rasage.

Barbear é fácil... Fórmula com ativos suaves e hidratantes para a proteção da pele. Especialmente desenhado para abrir os poros, hidratar a pele e amolecer a barba para facilitar o barbear.

Crème pós barbear Crème après-rasage

u.m.vta: 1  6 

250 ml

PH 5.5

REF. 04864



Idéale pour les peaux sensibles. Ses composants régénérants et apaisants la rendent idéale pour le rasage, produisant une agréable sensation de fraîcheur et d'hydratation.

Ideal para peles sensíveis. Os seus componentes regenerativos e calmantes o tornam ideal para depois do barbear, dando uma sensação agradável de frescura e hidratação.

Petit présentoir Pommade captain cook
Pequeno Pomada EXPOSITOR captain cook

u.m.vta: 1  1

REF.06441

- 6 pommades de chaque ref. (50 ml y 100 ml)
- CADEAU: présentoir en bois, 2 affiches, 25 catalogues, 1 sac, 1 chapeau
- 6 pomadas de cada ref. (50 ml e 100 ml)
- GRATIS: display de madeira, 2 cartazes, 25 catálogos, 1 bolsa, 1 chapéu



REF.06441/01

Affichage vide
Empty display





Présentoir grand captain cook barbe + cheveux
Expositor grande captain cook barba + cabelo

u.m.vta: 1  1

REF.04944

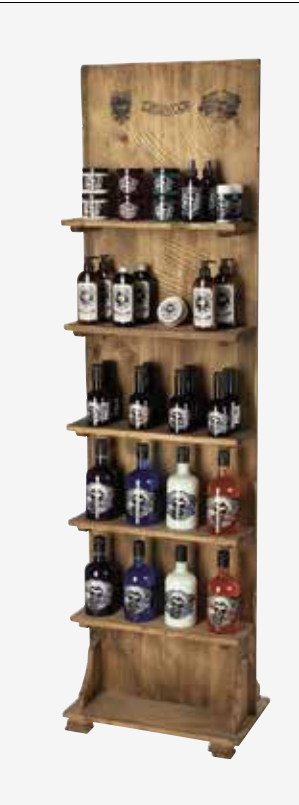
- 2 unités de chaque référence.
- CADEAU: présentoir en bois, 8 t-shirts, 2 casquettes, 2 sacs et 50 catalogues.
- 2 unidades de cada referência.
- GRATIS: display de madeira, 8 camisetas, 2 bonés, 2 malas e 50 catálogos.



u.m.vta: 1  1

REF.04944/01

Affichage vide
Exibição vazia

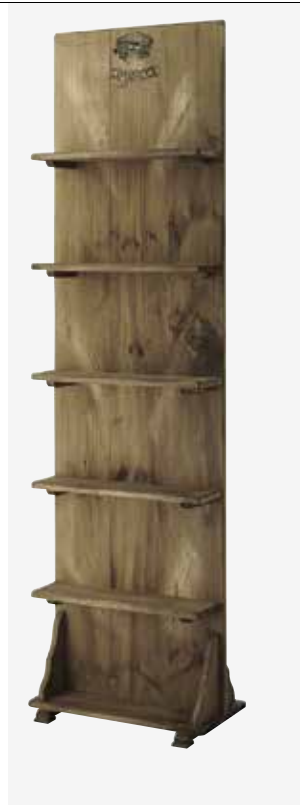



THE SHAVING CO. c'est un concept de style de vie 100% mexicain qui définit l'homme moderne, avec une collection de produits de soins personnels pour hommes fabriqués à la main, développés avec la meilleure technologie et les ingrédients de la plus haute qualité qui caractérisent nos produits dans le monde entier. Depuis 2014, THE SHAVING CO. combine l'expérience parfaite de nos salons de coiffure exclusifs avec la créativité de nos artistes et designers, toujours à l'avant-garde avec des produits et des traitements pour le soin des cheveux des hommes. RASAGE CO. C'est une expérience unique et inévitable qui harmonise la "masculinité" avec le "style de vie", depuis la conception d'un toilettage optimal, fondé sur le bien-être et le respect de l'environnement.

Notre collection de 25 produits est présentée dans quatre séries spécialisées:

CHEFS D'OEUVRE COIFFANTS

SÉRIE NOXIDIL R

SÉRIE BEARD

SÉRIE DE RASAGE

The shaving co. é um conceito de estilo de vida 100% mexicano que define o homem moderno, com uma coleção de produtos de cuidados masculinos feitos à mão, desenvolvidos com a melhor tecnologia e ingredientes da mais alta qualidade que caracterizam nossos produtos em todo o mundo. Desde 2014, o THE SHAVING CO. combina a perfeita experiência de nossas barbearias exclusivas com a criatividade de nossos artistas e designers, sempre na linha de frente com produtos e tratamentos para o cuidado do cabelo dos homens. SHAVING CO. é uma experiência única e inevitável que harmoniza a "masculinidade" com o "estilo de vida", a partir da concepção de uma higiene ideal, baseada no bem-estar e no cuidado com o meio ambiente.

Nossa coleção de 25 produtos é apresentada em quatro séries especializadas:

SÉRIE DE CABELO MASTERPIECES STYLING

SÉRIE NOXIDIL R

SÉRIE BEARD

SÉRIE DE BARBETE



Après-rasage splash After-shaves

u.m.vta: 1  5

La Shaving Co. AFTER SHAVES est une série de lotions après-rasage hypoallergéniques, testées dermatologiquement et non alcoolisées dans des petits emballages soigneusement mélangés pour un soin et un rasage supérieurs de l'homme, en utilisant seulement 100 ingrédients Premium. % naturel, délice avec des notes pures et rafraîchissantes dans chacun de ses arômes.

Avantages:

- Fournit une hydratation et une nutrition supérieures pour les follicules de la peau et des cheveux sans agents chimiques.
- Il réduit considérablement la sensation de démangeaisons et de peau sèche.
- Il réduit considérablement l'irritation et la rougeur de la peau.
- Ne contient pas d'alcool.
- Produit hypoallergénique.
- Diminue l'apparition de l'acné.

A Shaving Co. after-shaves, uma série de loções hipoalergênicas, dermatologicamente testadas e não-alcoólicas, em embalagens pequenas cuidadosamente misturadas para cuidados superior, usando apenas ingredientes premium 100 % natural, delicia-se com notas puras e refrescantes em cada um dos seus aromas.

Benefícios:

- Proporciona hidratação e nutrição superior para a pele e foliculos pilosos sem agentes químicos.
- Reduz significativamente a sensação de irritação e pele seca.
- Não contém álcool.
- Produto hipoalergênico.
- Diminui a aparência de acne.

- Bois de santal
- Sândalo

100 ml

REF.06376



- Citrus
- Citrus

100 ml

REF.06377



- Lavande
- Lavanda

100 ml

REF.06378





- 1888
- 1888

100 ml

REF.06379



Baume à barbe Bálsamo para barba

u.m.vta: 1  24 

60 ml

Citrus

REF. 04488



Wilderness

REF. 04490





Woodland

REF. 04489



Huile de barbe Óleo para barba

u.m.vta: 1  24 

30 ml

Woodland

REF. 04486

Wilderness

REF. 04487



Baume à barbe Mr. Bear Family parfait pour un usage quotidien. L'hydrate, en la rendant plus exubérante, douce et agréable au toucher. Formulé uniquement avec des produits naturels. C'est une cire dure et doit être chauffée avant l'application, en la conservant dans votre poche, en la frottant avec vos doigts ou en la touchant avec le sèche-cheveux.



Bálsamo para barba Mr. Bear Family perfeito para o uso diário. Hidrata tornando mais exuberante, suave e agradável ao tato. Feita apenas com produtos naturais. É uma cera dura e deve ser aquecida antes da aplicação, guardando no bolso, esfregando-a com os dedos ou com um pequeno aquecimento com o secador de cabelo.

Huile à barbe Mr. Bear Family élaborée uniquement avec des huiles naturelles. Elle adoucit et laisse la barbe gérable pour nourrir la peau. Cela aide à éviter les rougeurs et les irritations. Elle hydrate la barbe en la laissant douce, exubérante et facile à coiffer.

Óleo para barba Mr. Bear Family feito apenas à base de óleos naturais. Suaviza e deixa a barba maleável além de nutrir a pele. Ajuda a evitar a irritação. Hidrata a barba deixando-a suave, exuberante e fácil de pentear.

Baume pour moustache



Bálsamo para bigode

u.m.vta: 1  24 

REF. 04493

Wilderness

30 ml

u.m.vta: 1  24 

REF. 04492

Citrus

30 ml





Le baume à moustache Mr. Bear Family pour embellir et façonner la moustache. Cire dure qui colle bien et laisse la moustache dans la forme désirée. La cire est faite à la main, en utilisant uniquement des ingrédients naturels. Avec du beurre de karité, de la cire d'abeille et des huiles essentielles.

Bálsamo para bigode Mr. Bear Family para embelezar e dar forma ao bigode. Cera dura que fixa bem e deixa o bigode com a forma desejada. A cera é feita manualmente, utilizando apenas ingredientes naturais. Com manteiga de Karité, cera de abelha e óleos essenciais.



L'huile de rasage Mr bear Family Óleo de barbear Mr bearFamily

u.m.vta: 1  24 

30 ml



REF. 04495

L'huile de rasage Mr. Bear Family pour une expérience de rasage agréable. Fabriquée à partir d'huiles naturelles. Grâce à sa haute densité, la peau ne l'absorbe pas. Elle adoucit la barbe, la rend plus facile à raser, et agit comme un bouclier protecteur pour la peau pendant et après le rasage. Tout cela fait glisser la lame plus facilement sur la peau. Elle aide également à soulager les rougeurs, les irritations, les démangeaisons et la sécheresse de la peau après le rasage.

Óleo de barbear Mr. Bear Family para uma agradável experiência ao barbear. Feito a partir de óleos naturais. Graças à sua elevada densidade a pele não o absorve. Amolece a barba, pelo que a torna mais fácil de barbear, e atua como um escudo protetor para a pele durante e depois do barbear. Tudo isto faz que a lâmina deslize mais suavemente na pele. Não irrita, evita a pele seca depois do barbear.



Baume à lèvres Mr. Bear Family Bálsamo labial Mr. bear Family

u.m.vta: 1  48 

15 ml

Pink grape
REF. 04496



15 ml

Coco
REF. 04498



15 ml

Mint
REF. 04497



Lèvres douces et protégées . 100% naturel et fait à la main . Avec des arômes agréables de raisin rose, de menthe et de noix de coco. Il nourrit, protège et adoucit les lèvres dès la première application. Avec de l'huile de coco, de l'huile de jojoba, du beurre de karité, de la cire de carnauba et des huiles essentielles.

Lábios suaves e protegidos. 100% natural, feito à mão. Com agradáveis aromas a Uva, Rosa, Menta e Coco. Nutre, protege e suaviza os lábios desde a primeira aplicação. Com óleo de coco, jojoba, manteiga de karité, cera de Carnaúba e óleos essenciais.



Pierre d'alun 100% naturelle Pedra de alumínio 100% natural

u.m.vta: 1  378

75 g

REF.04220



Coupée à la main, pour apaiser la peau et l'irritation après le rasage.

Cortada à mão, para acalmar a pele e a irritação depois do barbear.

Savon de rasage à la pierre d'alun Sabão de barbear com alumínio

u.m.vta: 1  24

100 g

REF.04219



Savon de rasage à la pierre de alun. Sa formule unique 100% à base de Pierre d'Alun et de Beurre de Karité prépare la zone pour le passage du rasoir et fait du rasage un rituel très agréable.

Sabão de barbear com alumínio. A sua fórmula única 100% à base de Pedra de Alumínio e Manteiga de Karité prepara a pele para a passagem da navalha e faz do barbear um ritual muito agradável.

Crayon hémostatique Lápis hemostático

u.m.vta: 12  1440

12 g

REF.04218



Granel
Bulk

REF.04218/01

Crayon hémostatique pour le traitement des micro-coupures dans le rasage. Fabriqué avec de l'alun de potassium. Certificat CE. Usage externe et personnel. Il est préparé dans un tube de voyage pratique et sûr pour une utilisation facile.

Lápis hemostático para o tratamento de microcortes feitos ao barbear. Com alumínio de potássio. Certificado CE. Uso externo e pessoal. Embalado num tubular prático e seguro para facilitar a sua utilização.

Kit de rasage osma Kit barbear osma

u.m.vta: 1  1

REF.04221



Composé par:

- Boîte en bois
- Crayon hémostatique 12 g.
- Savon de rasage à la pierre d'alun 100 gr
- Pierre d'alun 75 g
- Brosse à cheveux en bois

- *Composto por*
- Cofre de madeira
- Lápis hemostático 12 g.
- Sabão de barbear com alumínio 100 gr
- Pedra de alumínio 75 g
- Pincel de madeira

MYRSOL



Massage à l'eau de citron régénérant la couche naturelle de la peau
Massagem água de limão, regeneradora da epiderme

u.m.vta: 1  8

180 ml

REF.03866

Régénérateur de la couche acide naturelle de l'épiderme de la peau et de la peau. En général, l'acide citronné est efficace contre les boutons et la séborrhée du visage et adoucit la peau. Rasage quotidien sans douleur et apaise instantanément la piqûre du rasage. Tonique astringent Il produit une sensation extraordinaire de fraîcheur et un arôme agréable. Recommandé pour les peaux grasses. Solution hydroalcoolique.

Regenerador da epiderme, da em geral, o ácido de limão é eficaz contra a seborréia facial e suaviza a pele. Usar tônico adstringente produz uma sensação extraordinária de frescura e tem um aroma agradável. Recomendado para pele oleosa. Solução hidroalcoólica.

200 ml

REF.04352



Massage antesol pour avant et après rasage
Massagem antesol para o antes e depois do barbear

u.m.vta: 1  8

200 ml

REF.04650

Massage mysol avantol. Pour avant et après le rasage. Il favorise la régénération des cellules cutanées endommagées et réduit la sensation de douleur. Indiqué pour traiter la peau sèche comme un hydratant. Le résultat est une peau plus lisse et plus saine. Recommandé pour les peaux sèches. Solution hydroalcoolique.

Para antes e depois do barbear. Favorece a regeneração das células da pele danificadas e reduz a sensação de dor. Indicado para tratar a pele seca, hidratante. O resultado é uma pele mais suave e saudável. Recomendado para pele seca. Solução hidroalcoólica.

180 ml

REF.03867

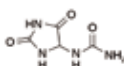
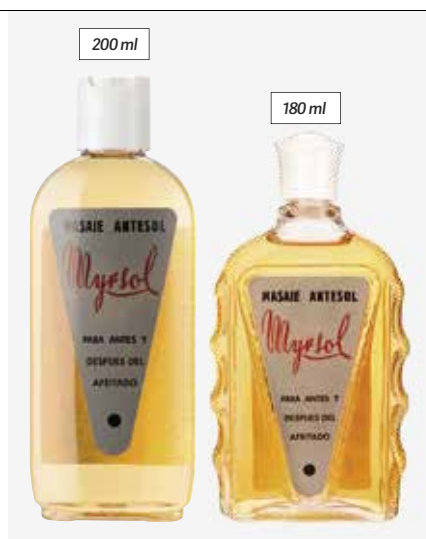
Alantoína
Allantoin

Myrsol

Après rasage (after shave) formule k tonique. Rafrâchissement mentolé

After shave fórmula k tónico. Refrescante com mentol

u.m.vta: 1  8

200 ml

REF.04643

Formule après-rasage k. Son action rafraîchissante et tonique aide à soulager la douleur et les irritations. Si délicate que soit votre peau, elle conserve son hydratation et son élasticité naturelle, évitant ainsi son vieillissement prématuré. Recommandé pour les peaux sèches. Solution hydroalcoolique.

180 ml

REF.03872

Após de barbear. Sua ação refrescante e tônica ajuda a aliviar a dor e a irritação. Não importa quanto delicada seja a sua pele, retém a umidade e a elasticidade natural, prevenindo o envelhecimento prematuro da pele. Recomendado para pele seca. Solução hidroalcoólica.



Après rasage (after shave) eau balsamique régénérante de la peau

After shave água balsâmica regeneradora da pele

u.m.vta: 1  8

200 ml

REF.04642

Excellent régénérateur de peau Irritation apaisante du rasage. Il est fabriqué à partir de substances extraites de romarin, de thym, de lavande et d'autres plantes indiquées pour décongestionner les parties affectées par le frottement, les ecchymoses et après le rasage. Recommandé pour les peaux grasses. Solution hydroalcoolique.

180 ml

REF.03875

Excelente regenerador de pele. Calma a barba. É feito com substâncias extraídas de alecrim, tomilho lavanda e outras plantas indicadas para descongestionar as partes afetadas. Recomendado para pele oleosa. Solução hidroalcoólica.



Émulsion pour rasage sans alcool pour massage avant et apres rasage

Emulsão para barbear sem álcool para massagem antes e depois do barbear

u.m.vta: 1  8

200 ml

REF.04587

u.m.vta: 1  8

180 ml

REF.03869

u.m.vta: 1  16

75 ml

REF.04887

- Roll-on
- Roll-on



Indications: se raser sans douleur sans brosse ni savon et pour le massage avant et après le rasage. Pour un rasage parfait des barbes les plus difficiles et des peaux les plus délicates. Un produit aux effets surprenants. Cette émulsion est hautement hydratante, nourrissante, hémostatique, analgésique. Indiqué pour les moustaches et le contour de la barbe. Recommandé pour les peaux sensibles. Solution sans alcool.

Indicações: barbear-se sem dor sem escova ou sabão e pela massagem antes e depois do barbear. Para um barbear perfeito para a barba mais difícil e para a pele mais delicada. Um produto com efeitos surpreendentes. Esta emulsão é altamente hidratante, nutritiva, hemostática, analgésica. Indicado para bigodes e contorno de barba. Recomendado para peles sensíveis. Solução não alcoólica.

Massage extra après rasage Massagem extra aftershave

u.m.vta: 1  8

180 ml

After shave

REF.03877



Lotion apaisante de toute sorte d'irritation produite par le rasage. Elle donne à la peau douceur et une agréable sensation balsamique et de fraîcheur, de guérison.

Loção calmante para qualquer tipo de irritação produzida pelo barbear. Dá à pele elasticidade, tonicidade e uma agradável sensação de frescura, cicatrização e balsâmica.

Massage Mentisol Massagem Mentisol

u.m.vta: 1  8

180 ml

REF.03878



Il a des propriétés curatives astringentes, il équilibre la fonction des glandes sébacées en évitant l'apparition de boutons sur la peau. Il aide à prévenir les irritations et les infections cutanées. Hémostatique efficace contre les microcoupures de rasage.

Tem propriedades cicatrizantes, adstringentes, equilibra a função das glândulas sebáceas evitando a aparição de borbulhas na pele. Ajuda a prevenir irritações e infeções da pele. Hemostática eficaz contra os microcortes do barbear.

Tonique pour le visage - Formule C Tónico facial Fórmula C

u.m.vta: 1  8

180 ml

REF.03874



Indiqué pour le soin de la peau, en particulier de la peau grasse. Régénère l'épiderme, rafraîchit et répare la peau après le rasage hydratant, relaxant, apaisant. Recommandé pour les peaux grasses. Une solution hydroalcoolique.

Indicado para o cuidado da pele, especialmente para peles oleosas. Regenera a epiderme, refresca e repara a pele depois do barbear hidratante, relaxante e calmante. Recomendado para peles oleosas, solução hidroalcoólica.

Massage facial Plastic Shaves Massagem facial Plastic Shaves

u.m.vta: 1  8

180 ml

REF.03871



Pour obtenir un rasage quotidien sans douleur ni gêne. Très approprié également pour neutraliser les piqûres de moustiques et autres diptères. Il améliore la texture et le ton de la peau et l'aspect général. Recommandé pour les peaux sensibles. Une solution hydroalcoolique.

Para conseguir barbear-se diariamente sem dor e sem problemas. Apropriado também para neutralizar picaduras de mosquitos e outros insetos. Melhora a textura, o tom da pele e o aspeto em geral. Recomendado para peles sensíveis. Solução hidroalcoólica.

Massage électrique Massagem electric

u.m.vta: 1  8

180 ml

REF.03868



Lotion indiquée pour lubrifier la peau et la machine électrique avant le rasage. Permet le glissement de la machine pour réduire le frottement et l'irritation de la peau. Solution alcoolique.

Loção indicada para lubrificar a pele e a máquina elétrica antes do barbear.

Permite que a máquina deslize melhor, reduzindo a fricção e a irritação da pele. Solução hidroalcolólica.

Massage myrsol blue after shave Massagem blue

u.m.vta: 1  8

180 ml

REF.03873



Myrsol-After shave blue. Le complément parfait après le rasage pour ses propriétés toniques et apaisantes. Excellent pour les affections cutanées: inflammation, irritation, déshydratation. Il fournit de la fraîcheur, de la tonicité et de la vitalité. Il a une fragrance distinctive de longue durée en contact avec la peau, recommandé pour les peaux sèches. Solution hydroalcolique.

Myrsol-After shave blue. O complemento perfeito para depois do barbear, pelas suas propriedades tónicas e calmantes.

Excelente para problemas de pele: inflamação, irritação, desidratação. Dá frescura, tonicidade e vitalidade. Possui uma fragrância distinta e duradoura ao contato com a pele, recomendado para peles secas. Solução hidroalcolólica.

Lotion capillaire tonifiante myrsol Loção capilar revitalizante myrsol

u.m.vta: 1  6

235 ml

REF.04644



- Régénératrice du cuir chevelu, anti-pelliculaire et
- anti-séborrhéique. PAS DE RINÇAGE

• Regeneradora do couro cabeludo, anticasca e anti seborreica. SEM ENXAGUAR

u.m.vta: 1  12

1000 ml

REF.06242

u.m.vta: 1  8

200 ml

REF.03876



- Savon liquide pour rasage brosse
- Sabão líquido para barbear com pincel

Matches hémostatiques 20 services

Fosforos hemostáticos 20 serviços

THE
LEGENDS

u.m.vta: 1  16

REF.06194

- Formule 100% naturelle, facile à utiliser
 - Antiseptique
 - Boîte de présentation par unités
 - 50 pochettes par boîte
 - 20 allumettes dans chaque livret
 - 300 gr
 - Fabriqué en Chine
- Expositor 50 caixitas. 20 unidades cada caixita
 - Fórmula 100% natural
 - 300 gr
 - Fabricado na PRC



Pommade THE LEGENDS

Pomada THE LEGENDS

u.m.vta: 1  12

120 ml

REF.06195



Gel THE LEGENDS

Gel THE LEGENDS

u.m.vta: 1  12

220 ml

REF.06197



Facile à appliquer, remodeler, facilement enlever, fixation forte

- Fixation forte - pour toute la journée
- Odeur douce et propre
- Consistance légère
- Couleur claire
- Luminosité moyenne
- Convient à tous les styles
- Facile à appliquer
- Pot en plastique blanc
- Style vintage
- 4 oz / 120 ml
- Fabriqué dans l'UE

Fácil de aplicar, remodelar, remover, fixaçãõ forte

- fixaçãõ forte - durante todo o dia
- Cheiro suave e limpo
- Consistência de luz
- Cor clara
- Brilho médio
- Adequado para todos os tipos de estilos
- Fácil de aplicar
- Jarra de plástico branco
- Estilo vintage
- 4 oz / 120 ml
- Produzido na UE

Produit "old school" fixation forte, nutritive, restylante.

- Fixation forte - toute la journée
- Parfum
- Consistance lisse
- Couleur rouge semi-transparente.
- Brillance moyenne sur cheveux mouillés
- Mat moyen sur cheveux secs
- Toutes sortes de styles
- Pot en plastique blanc
- Style vintage
- 4 oz / 220 ml
- Produit dans l'UE

Produto "old school" forte, nutritivo, restyling fixaçãõ.

- Fixaçãõ forte - o dia todo
- Fragrância
- Consistência suave
- Cor vermelha semitransparente.
- Brilho médio no cabelo molhado
- Meio fosco no cabelo seco
- Todos os tipos de estilos
- Estilo vintage
- 4 oz / 220 ml
- Produzido na UE

Shampooing prévention anti-chute

Champô prevenção da queda

TASSEL
PROFESSIONAL HAIR COSMETICS

u.m.vta: 1  12

1000 ml

REF.03566

- Shampooing formulé spécifiquement pour lutter contre la chute des cheveux, car il combine des protéines et des bionutriments d'origine végétale, qui agissent comme des décongestionnants et des revitalisants, tout en évitant ainsi les irritations.
- Nettoie en profondeur, en éliminant les graisses qui se forment sur le cuir chevelu, permettant ainsi aux nouveaux cheveux de se développer sans entrave.
- Les cheveux sont doux, brillants et soyeux.

u.m.vta: 1  6

400 ml

REF.03555

- *Champô formulado especificamente para combater a queda de cabelo, visto que combina proteínas e bio-nutrientes de origem vegetal, que atuam com descongestionante e revitalizante evitando assim a irritação.*
- *Limpa em profundidade, eliminando a oleosidade que se forma no couro cabeludo permitindo assim que o cabelo cresça naturalmente.*
- *O cabelo fica suave, brilhante e sedoso.*



Ampoules

Ampolas

u.m.vta: 1  6

REF.03550

- 12 ampoules prévention anti-chute
- Shampooing prévention anti-chute 400 ml
- *12 ampolas prevenção queda*
- *Champô de prevenção 400 ml*



u.m.vta: 1  6

REF.03551

- 12 ampoules prévention anti-chute
- 10 ml chaque flacon
- *12 ampolas prevenção queda*
- *10 ml cada frasco*





Les meilleurs nutriments pour le cuir chevelu et sont des protéines d'origine végétale. Ils améliorent l'absorption de ceux-ci et favorisent l'oxygénation du follicule pileux, en réduisant ainsi la perte de cheveux. Les nutriments végétaux agissent également comme décongestionnants et revitalisants, en empêchant ainsi l'irritation. La kératine répare et fortifie les cheveux, leur donnant du volume et de la brillance.

Os melhores nutrientes para o couro cabeludo são as proteínas de origem vegetal. Aumentam a absorção destes e favorecem a oxigenação do foliculo piloso, diminuindo assim a queda do cabelo. Os nutrientes vegetais também atuam como descongestionantes e revitalizantes, evitando assim a irritação. A queratina repara e fortalece o cabelo, dando-lhe volume e brilho.

Fibre capillaire

Fibra capilar

 u.m.vta: 1  6 

- Avec distributeur
- Pour hommes et femmes. Idéales pour la perte de densité capillaire. Elles dissimulent les zones ayant peu de cheveux, rapidement et naturellement
- Elles adhèrent aux cheveux et leur apportent volume et épaisseur
- Faciles à appliquer, en agitant le pot au-dessus de la zone d'application
- Disponibles en 6 couleurs : Noir, Châtain Foncé, Châtain Moyen, Châtain Clair, Blond Foncé et Gris Clair qui s'adaptent à la couleur naturelle des cheveux

- Para homem e mulher. Ideal para a perda de densidade capilar. Dissimula as zonas com pouco cabelo, de forma rápida e natural
- Adere ao cabelo conferindo-lhe mais volume e espessura
- Aplica-se facilmente, agitando o frasco em cima da zona de aplicação
- Disponível em 6 cores: cor preto, Castanho Escuro, Castanho Médio, Castanho Claro, Louro Escuro e Cinzento Claro que se adaptam à tonalidade da cor natural do cabelo
- Com dispensador

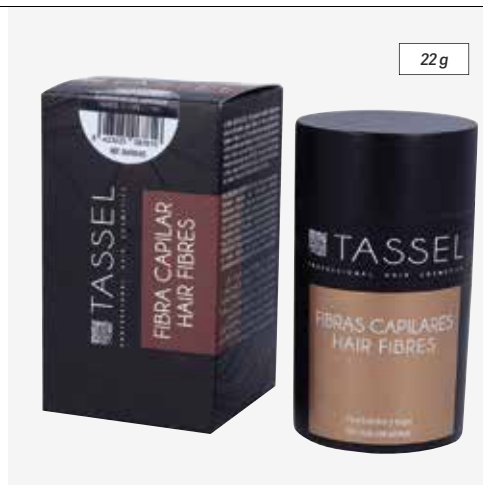

Noire · Preto

REF.06436/50

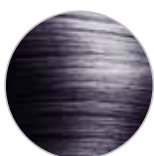

Gris clair · Cinza claro

REF.06436/72

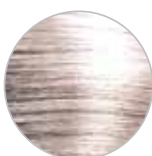

Blond foncé · Loiro escuro

REF.06436/66

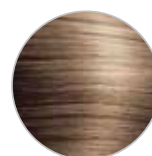

Brun foncé · Castanho escuro

REF.06436/67



Châtaignier moyen · Castanha média

REF.06436/76

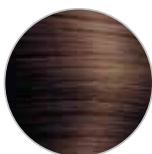



Châtain clair · Castanho claro

REF.06436/65



Pulvérisateur de fibres capillaires

Pulverizador de fibra capilar

 u.m.vta: 1  12 

REF.07208



- Facile d'utilisation
- Permet une distribution plus uniforme des fibres capillaires sur les zones spécifiques.
- Permet aux fibres d'adhérer aux cheveux naturels beaucoup plus facilement. Moins de produit est nécessaire pour obtenir le look souhaité.
- Facile à conserver

- Fácil de usar
- Permite uma distribuição mais uniforme das fibras capilares em áreas específicas.
- Ele permite que as fibras se fixem em seu cabelo natural com muito mais facilidade. É necessária menos quantidade de produto para obter a aparência desejada.
- Fácil de guardar

MODE D'EMPLOI :

Verser les fibres capillaires dans la bouteille en verre et positionner le pulvérisateur pour les pulvériser. Appuyer pour cela la pompe de haut en bas.

COMO USAR:

Despeje as fibras capilares no frasco de vidro e instale o atomizador para borrifá-las. Pressione a bomba para cima e para baixo para este propósito.

Laque fibre capillaire

Laca fibra capilar

u.m.vta: 1  30 

100 ml

REF.06649

Pour une fixation et une fixation maximales des fibres

Para máxima fixação das fibras



Présentoir fibres capillaires (en cadeau)

Expositor fibras capilares (de oferta)

u.m.vta: 1  1

REF.07801

Il inclue 6 tons de fibres capillaires + laque de fixation

Réf. 06436/50 Noir 22 g.

Réf. 06436/72 Gris clair 22 g.

Réf. 06436/66 Blond foncé 22 g.

Réf. 06436/67 Châtain foncé 22 g.

Réf. 06436/76 Châtain moyen 22 g.

Réf. 06436/65 Châtain clair 22 g.

Réf. 06649 Laque fixation fibres capillaires 100 ml.

- Inclui 6 tons fibras capilares + laca fixação
- Ref. 06436/50 Preto 22 g.
- Ref. 06436/72 Cinzento claro 22 g.
- Ref. 06436/66 Louro escuro 22 g.
- Ref. 06436/67 Castanho escuro 22 g.
- Ref. 06436/76 Castanho médio 22 g.
- Ref. 06436/65 Castanho claro 22 g.
- Ref. 06649 Laca fixação fibras capilares 100 ml.



Roll-on de cire pour homme

Roll-on cera homem

u.m.vta: 24  24

100 ml

REF.03858

Le système d'épilation au rouleau est optimal pour les professionnels qui cherchent à obtenir de meilleurs résultats. Les résines avec lesquelles nous fabriquons les cires peuvent être utilisées à une température plus élevée que la cire de basse fusion, avec l'avantage d'être appliquées au moyen d'une bande plus mince. Ainsi, la cire refroidit presque instantanément et la sensation de chaleur dans la peau est minimisée. La cire s'enlève facilement avec les bandes hygiéniques. Prix d'escalade combinables page 556-557-558.

O sistema roll-on de depilação é ideal para aqueles profissionais que buscam obter os melhores resultados. As resinas com as quais fabricamos as ceras podem ser usadas a uma temperatura mais elevada do que a cera de baixo ponto de fusão, com a vantagem de serem aplicadas por meio de uma tira mais fina. Assim, a cera esfria quase instantaneamente e a sensação de calor na pele é minimizada. A cera é facilmente removida com as tiras higiênicas. Página de preços de escalada combinável 556-557-558.



07

Mobilier et décoration Mobiliário e decoração

*Enseigne barbier, fauteuil, bac à shampoing,
chaises enfants, miroirs, et chariots coiffure...*



*Pólo de barbeiro, poltronas de barbeiro, lavató-
rios, cadeiras infantis, espelhos e carrinhos ...*



Enseigne de barbier

Pólos barbeiro

Avec cable
Com cabo

u.m.vta: 1  1 

REF. 04745

- | | |
|--|--|
| <ul style="list-style-type: none"> • Potencia: 12 W • Vitesse d'essorage: 50-60 RPM • Vintage enseigne de barbier noire • Option de lumière et / ou de rotation • Tension: 220-240V~ • Fréquence: 50/60 Hz | <ul style="list-style-type: none"> • Potência: 12W • Velocidade de giro: 50-60RPM • Pólo barbeiro preto vintage • Opção de luz e/ou rotação. • Voltagem: 220-240V ~ • Frequência: 50/60 Hz |
|--|--|

REF. 04578

- | | |
|---|---|
| <ul style="list-style-type: none"> • Potencia: 13 W • Vitesse d'essorage: 50-60 RPM • Enseigne de barbier noir lumineux et rotatif Ø 20 cm • Tension 220-240V~ • Fréquence: 50/60 Hz | <ul style="list-style-type: none"> • Potência: 13W • Velocidade de giro: 50-60RPM • Option de lumière et / ou de rotation • Pólo barbeiro preto luminoso e rotativo Ø 20 cm • Opção de luz e/ou rotação. • Voltagem: 220-240V ~ • Frequência: 50/60 Hz |
|---|---|

REF. 04744

- | | |
|---|--|
| <ul style="list-style-type: none"> • Potencia: 13 W • Vitesse d'essorage: 50-60 RPM • Enseigne de barbier chromé avec cadran lumineux. • Option de lumière et / ou de rotation • Tension: 220-240V~ • Fréquence: 50/60 Hz | <ul style="list-style-type: none"> • Potência: 13 W • Velocidade de giro: 50-60RPM • Pólo barbeiro cromado com esferaluminosa • Opção de luz e/ou rotação. • Voltagem: 220-240V ~ • Frequência: 50/60 Hz |
|---|--|

REF. 04743

- | | |
|--|--|
| <ul style="list-style-type: none"> • Potencia: 13 W • Vitesse d'essorage: 50-60 RPM • Enseigne de barbier chromé de grande taille • Option de lumière et / ou de rotation • Tension: 220-240V~ • Fréquence: 50/60 Hz | <ul style="list-style-type: none"> • Potência: 13 W • Velocidade de giro: 50-60RPM • Pólo barbeiro cromado grande • Opção de luz e/ou rotação. • Voltagem: 220-240V ~ • Frequência: 50/60 Hz |
|--|--|

REF. 04946

- | | |
|---|--|
| <ul style="list-style-type: none"> • Potencia: 17 W • Vitesse d'essorage: 50-60 RPM • Enseigne de barbier chrome petit modele • Option de lumière et / ou de rotation Tension: 220-240V~ • Fréquence: 50/60 Hz | <ul style="list-style-type: none"> • Potência: 17 W • Velocidade de giro: 50-60RPM • Pólo barbeiro chromed pole small • Opção de luz e/ou rotação. • Voltagem: 220-240V ~ • Frequência: 50/60 Hz |
|---|--|



L'origine du poste de barbier rouge blanche remonte à l'époque médiévale où les barbiers ont opéré leurs clients. Ainsi que des extractions dentaires. Le poteau avait à l'origine un bassin en bronze en haut, représentant le conteneur où les sangsues étaient stockées, et un autre en bas, faisant allusion au destinataire recevant le sang. Le poteau lui-même symbolise le bâton ou le bâton que le patient a saisi pendant la procédure pour faciliter la circulation sanguine. C'est pourquoi le pôle barbier est associé aux services offerts, dont la sangria. Historiquement, il était représenté avec des bandages sanglants enroulés autour d'un poteau.

A origem do posto do barbier vermelho-branco remonta à era medieval, onde os barbeiros realizavam cirurgias em seus clientes. Bem como extrações dentárias. O poste originalmente tinha uma bacia de bronze na parte superior, representando o recipiente onde as sanguessugas estavam armazenadas, e outra na parte inferior, aludindo ao receptor que recebia o sangue. O próprio bastão simboliza o bastão que o paciente agarrou durante o procedimento para facilitar o fluxo sanguíneo. Por isso, o poste de barbier está associado aos serviços oferecidos, entre eles a sangria. Historicamente, era retratado com bandagens sangrentas enroladas em um poste.

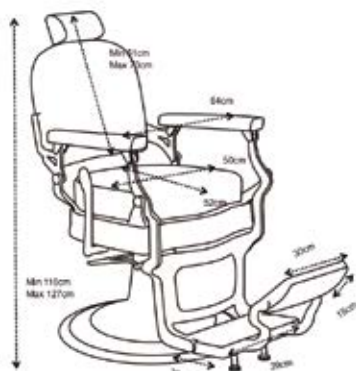

Fauteuil de coiffure **SPRINGFIELD** Cadeira de barbeiro **SPRINGFIELD**

u.m.vta: 1  1●
REF.06955SCAN
ME!

Le nouveau fauteuil de barbier Springfield est conçu dans un style moderne mais sans perdre sa fonctionnalité et ses lignes classiques. La chaise a une pompe hydraulique qui nous permet de soulever et d'abaisser le siège, afin que nous puissions placer notre client à la hauteur qui convient le mieux à notre travail. La mousse du dossier a une épaisseur de 6 cm et l'assise de 11 cm cela fera que notre client s'adaptera bien au fauteuil et sera très confortable. L'appuie-tête est amovible et réglable afin que nous puissions l'adapter à chaque travail. Le dossier de la chaise peut être incliné de 108 degrés, tandis que nous inclinons le dossier, la structure du repose-pieds sera également inclinée pour donner un maximum de confort.

A nova poltrona de barbeiro de Springfield foi projetada em estilo moderno, mas sem perder a funcionalidade e as linhas clássicas. A cadeira possui uma bomba hidráulica que permite elevar e abaixar o assento, para que possamos colocar nosso cliente na altura que melhor se adequa ao nosso trabalho. A espuma do encosto tem uma espessura de 6 cm e o assento de 11 cm, isso fará com que nosso cliente se adapte bem à poltrona e seja muito confortável. O apoio de cabeça é removível e ajustável para que possamos adaptá-lo a cada trabalho. O encosto da cadeira pode ser inclinado em 108 graus, enquanto inclinamos o encosto, a estrutura do apoio para os pés também será inclinada para proporcionar o máximo conforto.

Fauteuil de coiffure **STAFFORD** Cadeira de barbeiro **STAFFORD**

u.m.vta: 1  1 ● ●
REF.06956/50 **REF.06956/50**SCAN
ME!

Le nouveau fauteuil de barbier Stafford est conçu avec des lignes et des finitions rétro. Il est considéré comme un fauteuil «vintage» car il mélange l'acier et le tissu avec un effet usé. De qualité dernière génération, il est équipé d'une pompe hydraulique pour régler la hauteur du siège. Le repose-pieds est pivotant et le dossier est inclinable. L'appuie-tête est amovible et également réglable pour l'adapter à chaque travail. Disponible en noir et marron. Inclinaison d'environ 120 degrés

A nova poltrona de barbeiro Stafford foi projetada com linhas e acabamentos retrô. É considerada uma poltrona "vintage", pois mistura aço e tecido com um efeito desgastado. Com qualidade de última geração, é equipado com uma bomba hidráulica para ajustar a altura do assento. O apoio para os pés é giratório e o encosto reclinável. O apoio de cabeça é removível e também ajustável para adaptá-lo a cada trabalho. Disponível nas cores preto e marrom. Inclinação de aproximadamente 120 graus.

Fauteuil de coiffure VIGOR Cadeira de barbeiro VIGOR

u.m.vta: 1  1

REF.04888



REF.04888/73

SCAN
ME!

Le nouveau fauteuil de coiffure Vigor est conçu avec un style moderne mais sans perdre sa fonctionnalité et ses lignes classiques. Le fauteuil est équipé d'une pompe hydraulique qui vous permet de soulever et d'abaisser le siège et de placer ainsi le client à la hauteur convenable. La mousse du dossier a une épaisseur de 13,5 cm et celle de siège est de 11,5 cm, ce qui permettra au client de bien s'adapter au fauteuil et se mettre à l'aise. L'appui-tête est amovible et réglable de sorte qu'il peut être adapté à chaque travail. Le dossier du fauteuil peut être incliné à 130°, en même temps que le dossier est incliné, la structure du repose-pieds s'inclinera également pour donner un maximum de confort.

A novo cadeira de barbeiro Vigor está concebido com um estilo moderno, mas sem perder a sua funcionalidade e linhas clássicas. O cadeira tem uma bomba hidráulica, a qual permite subir e baixar o assento e assim poderá situar o cliente à altura que melhor se adapte ao trabalho. A espuma do encosto tem uma espessura de 13,5 cm e a do assento é de 11,5 cm, isto fará com que o cliente se adapte bem ao assento e se encontre muito cómodo. O repousa-cabeças é extraível e ajustável, portanto, pode adaptar-se a cada trabalho. O encosto do assento pode ser inclinado 130°, quando isso é feito, o apoio-pés também se inclinará para dar o máximo conforto.

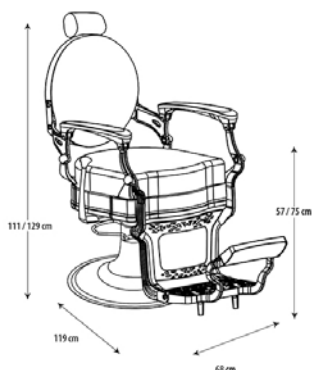

Fauteuil de coiffure classic Cadeira de barbeiro classic

u.m.vta: 1  1●
REF.06087/50●
REF.06087/73●
REF.06087/62SCAN
ME!

Nouveau fauteuil de coiffure CLASSIC avec des lignes classiques et des finitions de dernière génération. Il est équipé d'une pompe hydraulique pour régler la hauteur du siège. Le repose-pieds est rotatif et le dossier est incliné pour offrir un maximum de confort au client. La mousse du dossier a une épaisseur de 2,5 cm alors que celle du siège est de 7,5 cm, ce qui permettra au client de bien s'adapter à la chaise et se sentir très à l'aise. Aussi l'appui-tête est amovible et réglable pour l'adapter à chaque travail. Disponible en trois couleurs noir, bordeaux et vert.

Nova cadeira de barbeiro CLASSIC com linhas clássicas e acabamentos de última geração. Está dotado de bomba hidráulica para regular a altura do assento. O apoio-pés é giratório e o encosto reclinável para dar o máximo conforto ao cliente. A espuma do encosto tem uma grossura de 2,5 cm e a do cadeira é de 7,5 cm, isto fará com que o cliente se adapte bem ao assento e se sinta muito cómodo. O repouso-cabeças é extraível e ajustável a diferentes trabalhos. Disponível em três cores; preto, granada e verde.

FAUTEUIL barbier noir CADEIRA BARBEIRO cor preto

u.m.vta: 1  1

REF. 03628

- Pivote à 360°
- Largeur du bras au bras 57 cm
- Tête 19 x 13 cm
- Dossier 51 x 41 cm
- Inclinable 130°
- Gira a 360°
- Largura de braço a braço 57 cm
- Cabeçal 19 x 13 cm
- Encosto 51 x 41 cm
- Reclinável 130°



Fauteuil barbier PERSONNALISÉ

Cadeira barbeiro hidráulica PERSONALIZÁVEL

u.m.vta: 1  1

REF.04508/01



PERSONNALISEZ VOTRE FAUTEUIL

1. DÉCIDEZ LA COULEUR DE LA BASE
2. CHOISISSEZ LA COULEUR DU SIÈGE



- Structure de la chaise : Fonte d'aluminium
- Les pièces chromées sont en bronze et en fer
- La structure sur laquelle se trouve le rembourrage est faite de pin
- Certificats de mousse et de revêtements
- Base recouverte de polyester peint (même système que les voitures)

PERSONALIZE A SUA cadeira

1. DECIDA A COR DA BASE
2. ESCOLHA A COR DO cadeira

- Estrutura do assento: Alumínio fundido
- As peças cromadas são em bronze e ferro
- A estrutura sobre a qual se encontra o tapete é de pinho
- Espuma e revestimentos Certificados
- Base coberta de poliéster pintado (Mesmo sistema que os carros)

Fauteuil basculant Cadeira basculante

u.m.vta: 1  1 

REF. 02975/50

- Inclinação 130° / Hidráulica
- Largura do braço ao braço: 57 cm
- Tête de chaise d'Anchua: 19 cm
- Tête amovible avec une position
- Dossier 51 x 41 cm
- Hauteur de la tête: 13 cm
- Distance entre le dossier et la tête 14 cm
- Poids: 32,5 kg

- Reclinável 130° / Hidráulica
- Largura do braço ao braço: 57 cm
- Largura de cabeça da cadeira: 19 cm
- Cabeça removível com uma posição
- Encosto 51 x 41 cm
- Altura da cabeça: 13 cm
- Distância entre o encosto e a cabeça 14 cm
- Peso: 32,5 kg



Fauteuil barbier TRADITIONAL Cadeira de barbeiro TRADITIONAL

u.m.vta: 1  1

REF.06089/50



SCAN
ME!

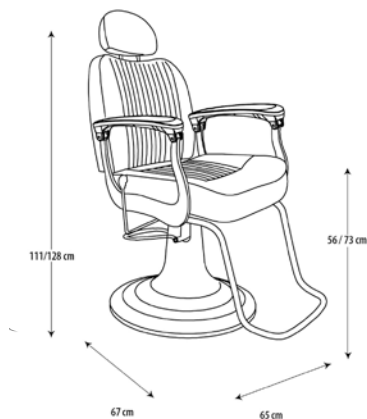

Le nouveau fauteuil de coiffure TRADITIONAL a été fabriqué comme un fauteuil sobre et maniable, avec un style très vintage, sans oublier le confort. Il est équipé d'une pompe hydraulique pour ajuster la hauteur de l'assise et du dossier inclinable pour donner un maximum de confort au client. La mousse du dossier a une épaisseur de 9 cm et le siège de 10 cm, ce qui permettra au client de bien s'adapter à la chaise et se sentir très à l'aise. L'appui-tête est amovible et réglable à différentes hauteurs. Il a également un repose-pieds confortable.

A nova cadeira de barbeiro TRADITIONAL foi fabricada como uma cadeira sóbria e fácil de manejar, de estilo muito vintage, sem esquecer a comodidade. Está dotada de bomba hidráulica para regular a altura do cadeira do encosto reclinável para dar o máximo conforto ao cliente. A espuma do encosto tem uma grossura de 9 cm e do cadeira de 10cm, isto fará que o cliente se adapte bem ao cadeira e se sinta muito cómodo. O repousa-cabeças é extraível e ajustável a diferentes alturas. Também tem um cómodo repousa-pés.

Bac lavage TRADITIONAL

Rampa de lavagem tRADITIONAL

| | |
|------------|---|
| u.m.vta: 1 |  1 |
|------------|---|

REF.06090/50

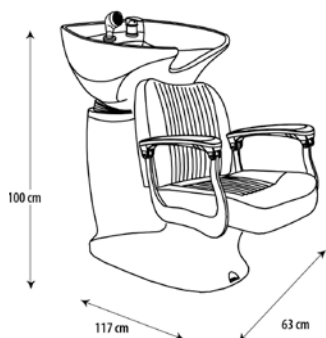

Le lave-tête TRADITIONAL suivant la ligne du fauteuil de coiffure TRADITIONAL (Ref.06089 / 50) a été fabriqué comme un lave-tête sobre et de style très vintage, sans oublier le confort. Complétez le design de votre salon avec ce lave-tête !

O lava-cabeças TRADITIONAL seguindo a linha do assento de barbeiro TRADITIONAL (Ref.06089/50) foi fabricado como um lava-cabeças sóbrio e de estilo muito vintage, sem esquecer a comodidade. Complete o design do seu salão com este lava-cabeças!

Bac lavage STAFFORD

Rampa de lavagem STAFFORD

| | |
|------------|---|
| u.m.vta: 1 |  1 |
|------------|---|



REF.06957/50



REF.06957/69

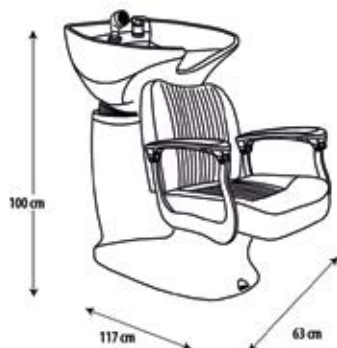



Le fauteuil Stafford, suivant la ligne du fauteuil de barbier «traditionnel» (référence 06089/50) suit également l'esthétique du lavabo «traditionnel» mais à la différence que le lavabo Stafford se caractérise par sa fabrication en acier et ont une finition usée «vintage»

O ramopa de lavagem Stafford, seguindo a linha de cadeira de barbeiro "tradicional" (referência 06089/50) também segue a estética do lavatório "tradicional", mas com a diferença de que o lavatório Stafford é caracterizado por ser feito de aço e tenha um acabamento «vintage» desgastado no assento.

Bac lavage STIL
Rampa de lavagem STIL

* Pièces de rechange disponible
 * Peças de reposição disponíveis

u.m.vta: 1  1 

●
REF. 02841

●
REF. 02841/54

○
REF. 02841/58



- Appui-bras et télécommande chromés.
- Tuile en céramique et base fibre de verre.
- Assise coulissante.
- Base longue 76 cm
- Largeur du siège 48 cm
- Dossier haut 41 cm
- Céramique 57x50x20cm
- Hauteur totale 95 cm

- Apoia-braços e comando cromados.
- Telha de cerâmica e base fibra de vidro
- Assento deslizável.
- Largura base 76 cm
- Largura assento 48 cm
- Altura encosto 41 cm
- Cerâmica 57x50x20cm
- Altura total 95 cm

Chaises pour enfants Assentos para crianças

u.m.vta: 1  1

Fauteuils pour enfants, de haute qualité, en métal et style vintage pour que l'expérience d'aller au salon de coiffure soit agréable et sans drames. karts à pédales pour les enfants qui fonctionnent sont démontés du support. Lumières décoratives et ceinture de sécurité. De plus, si le volant est tourné, les roues avant bougent. Ne contient pas de klaxon.

Assentos para crianças, de grande qualidade, feitas em metal e com estilo vintage para que a experiência de ir ao cabeleireiro seja agradável e livre de dramas. Carros com pedais que funcionam desmontados do suporte e luzes decorativas. Ao girar o volante movem-se as rodas dianteiras.



24 kg



REF.04728



26,8 kg



REF.04727



Fauteuil spécial pour enfants Cadeira especial para crianças

u.m.vta: 1  1

REF.02733



Coussins spéciaux pour enfants Almofadas especiais para crianças

u.m.vta: 1  2

REF.07329/50



Coussins spéciaux pour enfants Almofadas especiais para crianças

u.m.vta: 1  1

REF.03939

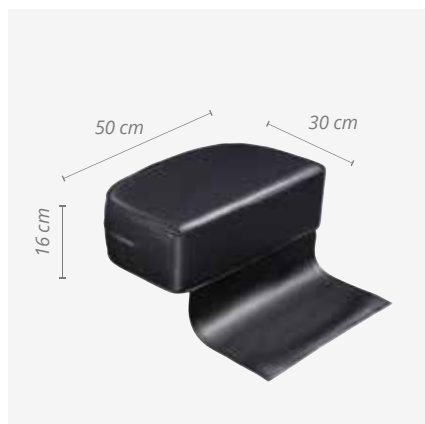

Coussins spéciaux pour enfants Almofadas especiais para crianças

u.m.vta: 1  1

● REF.04506/50 ● REF.04506/60

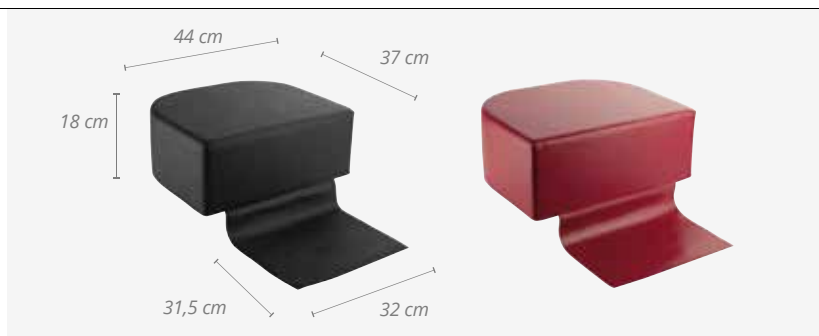

Nous avons également des coussins spéciaux adaptés à toutes les Fauteuils de coiffure qui permettent un travail plus confortable au professionnel car ils élèvent l'enfant à la bonne hauteur.

Também temos almofadas especiais aptos para qualquer salão de cabeleireiro que permitem um trabalho mais cómodo ao profissional, elevam a criança à altura idónea.

Coiffeuse murale barbier Espelho de parede barber

u.m.vta: 1  1

REF.06091

Le miroir mural BARBER, de style vintage, est fonctionnel et pratique pour que votre étagère supporte les objets que vous voulez. Apportez une touche "Old School" à votre salon!

O espelho de parede BARBER, estilo vintage, é funcional e prático pelas suas estantes para apoiar os objetos que deseja. Dé um toque da "old school" ao seu salão!



Coiffeuse rustique BARBER LINE Espelho rústico BARBER LINE

u.m.vta: 1  1

REF.06670

Coiffeuse en résine polyuréthane à base de mdf. Matériau avec de meilleures propriétés que le bois en termes de résistance et de stabilité, ignifuge auto-strié et classement antibactérien. Finition en bois rustique avec deux pièces décoratives imitant le fer. Rustique en noir. Toucher boisé, imitation parfaite.

Espelho fabricado em resina de poliuretano com base em mdf, material com as melhores propriedades que a madeira em relação à sua resistência e estabilidade e com qualificação ignífuga auto-extinguível e antibacteriana. Acabamento em madeira rústica com duas peças ornamentais que imitam o ferro e na cor preta. Tem um tato similar à madeira, imitação perfeita. Ideal para apoiar sobre qualquer superfície. Dispõe de uma base que lhe dá estabilidade.



Chariot de coiffure en bois et métal
Carrinho barbeiro madeira e metal

u.m.vta: 1  1



REF.04698/54



Bidon de CAPTAIN COOK
Bidão CAPTAIN COOK

u.m.vta: 1  1

REF.06054



Compoir de réception en bois et métal à effet miroir
Desk recepção de madeira e metal efeito espelho

u.m.vta: 1  1

REF.03935

Avec compartiments intérieurs en bois pour le stockage et l'étagère
 Com compartimentos de madeira interiores para armazenamento e prateleira



Canapé d'attente 3 places
Sofá de espera 3 lugares

u.m.vta: 1  1

REF.03950



En skai
 Em pele ecológica

Meuble coiffure de réception EARTH

Desk recepção EARTH

u.m.vta: 1  1

Graphite · Grafite

Blanc · Branco

Chêne · Carvalho



REF.04518/50

REF.04518/58

REF.04518/65

- Laminé en graphite
- Avec étagères réglables et 1 tiroir

- Laminado em grafite
- Com prateleiras ajustáveis e 1 gaveta



Rouleau 100 protections fauteuil

Rolo 100 protetor cadeira

u.m.vta: 1  1

REF.07239

SCAN
ME!

- Tenez les germes éloignés de vos fauteuils.
Désinfection rapide et facile : en quelques secondes, retirez la housse du fauteuil et jetez-la. Elle s'adapte à la plupart des fauteuils à dossier.
- 65+16 x 150 cm / 0,025 mm

- Mantenha os germes longe dos seus assentos.
Desinfecção rápida e fácil: em questão de segundos, retire a capa protetora do assento e deite fora. Adapta-se à maioria das cadeiras com encosto.
- 65+16 x 150 cm / 0,025 mm



Conteneur de serviettes Contentor toalhas

u.m.vta: 1  4

REF.03159



- Avec des roues
- Housse conteneur lavable.
- Structure en acier inoxydable
- Com rodas
- Bolsa contentora lavável
- Estrutura de aço inoxidável

Étagère rangement de serviettes Organizadores para pendurar toalhas

u.m.vta: 1  6

REF.04378

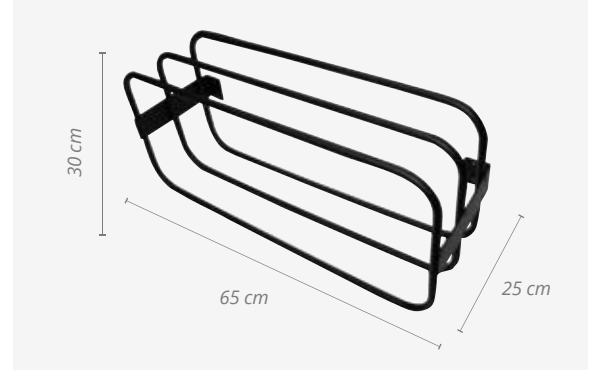

Douchette avec support Chuveiro com suporte

u.m.vta: 1  20

REF.03004



Kit de douchette adaptable Kit chuveiro adaptável

u.m.vta: 1  10

REF.01960



Mitigeur monocommande pour bac à douchette Mono-comando para rampa lavagem

u.m.vta: 1  50

REF.02837



Pommeau de douche ionique Chuveiro iónico

u.m.vta: 1  36

REF.03750

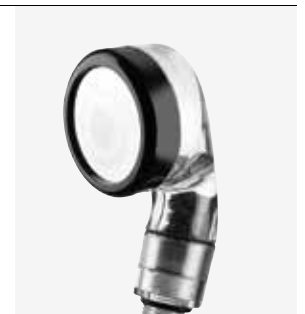

Économie d'eau
Meilleure qualité de l'eau.

Poupa água.
Melhora a qualidade da água.

Mitigeur monocommande et douchette pour lave-tête
Misturadora monocomando e chuveiro para lavagem de
cabeças

u.m.vta: 1  12

REF.07618

NEW

Douche avec support de tête de lavage
Chuveiro com suporte de lavatório

u.m.vta: 1  12

REF.07619

NEW

Pommeau de douche chromé
Chuveiro cromado

u.m.vta: 1  12

REF.07620

NEW

Douchette noire
Chuveiro de lavagem preto

u.m.vta: 1  12

REF.07625

NEW

Valve d'évier de lavage de tête
Válvula do lava-cabeças

u.m.vta: 1  12

REF.07626

NEW

Réducteur de débit d'eau
Redutor de fluxo de água

u.m.vta: 1  12

REF.07623

NEW



Tuyau d'évacuation du lave-tête jusqu'à 80 cm
Tubo de drenagem do lava-cabeças até 80 cm

u.m.vta: 1  12

REF.07624

NEW



Tube de douche flexible pvc 120 cm pour lavabo
Tubo flexível de chuveiro em pvc 120 cm para pia

u.m.vta: 1  12

REF.07621

NEW



Tube de douche en nylon flexible pour lave-tête
Tubo de chuveiro de nylon flexível para lavador de cabeça

u.m.vta: 1  12

REF.07781

NEW





08

Accessoires Acessórios

*Papier protecteur, vêtement barbier,
pulvérisateur, valises, hygiène...*



*Papel protetor, vestuário barbeiro,
pulverizador, malas, higiene...*

Le papier cou est un classique dans le salon de coiffure pour éviter les démangeaisons dans le cou et que les poils peuvent être tendus à l'intérieur.

A papel pescocço é um clássico na barbearia para evitar coceira no pescoço e para que os pelos possam entrar.

Pack 5 rouleaux papier kraft cou Pack 5 rolos de papel de colarinho kraft

RAGNAR
BARBER LINE

| | | | |
|-------------|---|----|---|
| u.m.vta: 20 |  | 20 |  |
|-------------|---|----|---|

REF. 07445

- 80 Utilisations
- Touché semblable au tissu
- Grande absorption des liquides
- Transpirable et résistant à l'humidité
- Garantie absolue d'hygiène pour vos clients
- Matière première issue de forêts reboisées et contrôlées
- Waterproof

- 80 Serviços
- Tato similar ao tecido
- Grande absorção dos líquidos
- Respirável e resistente à humidade
- Garantia absoluta de higiene para os seus clientes
- Matérias-primas procedentes de florestas com reflorestação e controladas
- Waterproof

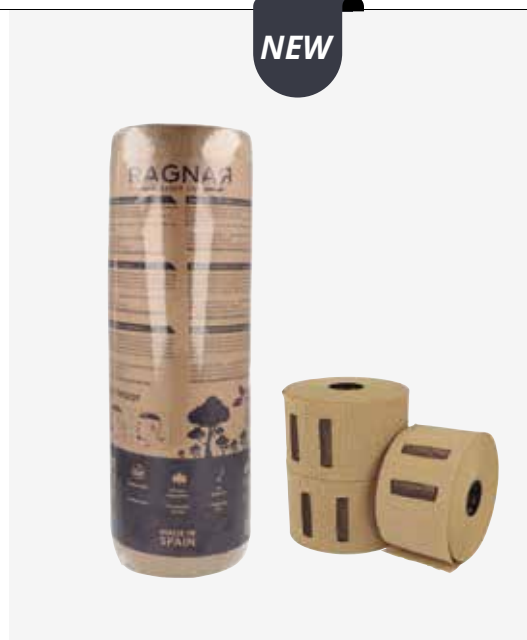

Sans cruauté animale
Sem crueldade com os animais



Sans produits chimiques
Sem químicos



Forêts durables
Florestas Sustentáveis





Compostable
Compostável



Produit naturel
Produto natural

Pack 5 rouleaux papier de cou Barber Line Pack 5 rolos papel pescoço Barber Line

Barber Line

| | | | |
|------------|---|---|---|
| u.m.vta: 6 |  | 6 |  |
|------------|---|---|---|

REF. 04651

- 100 services
 - Noir
 - Colle blanche
- 100 utilizações
 - Branca
 - Cola preta

Pack de 5 rouleaux de papier cou spécial pour salon de coiffure, couleur noire



Pack 5 rolos papel de pescoço especial barbearia, cor preta.



Pack 5 rouleaux papier de cou Barber Line

Pack 5 rolos papel pescoço Barber Line



Barber Line

u.m.vta: 6  6 

REF. 06596



SCAN
ME!

u.m.vta: 20  20 

REF. 06927



- 80 services
- Noir
- Colle blanche



- 80 utilizações
- Preta
- Cola branca

Du papier noir recyclé pour coU, qui ne blanchit pas, ne contient pas de chlore, pourrait être utilisé pour le produit alimentaire puisqu'il possède le certificat ISEGA et un certificat. FSC de matériaux provenant de forêts contrôlées, gestion forestière durable PEFC

O papel reciclado de pescoço cor preto, que não usa alvejante, não tem cloro, pois possui o certificado ISEGA e possui um certificado FSC de material de florestas controladas, manejo (florestal sustentável do PEFC)

Rouleau de papier cou

Rolo papel pescoço

u.m.vta: 100  100 



REF. 00681

- Colle bleue d'usage facile
- Qualité premium
- S'ajuste parfaitement et rapidement
- Hygénique. 1 seul usage.
- Papier jetable
- Élastique. S'ajuste à tous les cous.
- Conçu pour être utilisé dans les salons de coiffure et de barbier
- Prévient les picotements et démangeaisons au cou

- Cola azul para fácil colagem e posicionamento
- Qualidade premium
- Ajuste perfeito e rápido
- Descartável
- Elástico, ajustável em cada pescoço
- Projetado para cabeleireiros e barbeiros profissionais
- Não irritant



Séparateurs cheveux Separadores cabelo

u.m.vta: 1  50 

Sachet 2 séparateurs. Velcro
Pacote de 2 separadores. Velcro

REF.06440 REF.06613





06440



06613



Supports pour papier cou Porta rolos para papel pescoço



u.m.vta: 1  6 

REF. 00800

- Pour ref. 00681, 04651, 06296
- Para ref. 00681, 04651, 06296



Supports pour papier cou Porta rolos para papel pescoço



u.m.vta: 1  4 

REF. 06803

- Matière : abs noir
- Peut être accroché au mur.
- Material: ABS preto
- Pode-se pendurar na parede e espelho



Sachet de 50 protecteurs Pacote de 50 protetores

u.m.vta: 1  50 

REF. 06315



Protecteur d'oreille boîte 50 unites Ear hood

u.m.vta: 1  50



REF. 07008

- Dimensions: 2 * 4,5 cm
- Poids: 0,40 grammes
- Matière plastique

- Dimensiones: 2*4.5CM
- Peso: 0,40 gramos
- Material Plástico



Peignoir de coiffure silicone Penteador de silicone



u.m.vta: 1  10 

REF. 07006



Cape de coupe BARBER LINE Capa corte BARBER LINE



u.m.vta: 1  40 

REF.06988

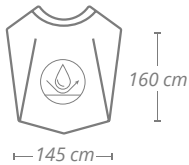

- Polyester pongé
- Hydrofuge
- Poids 150 g
- Bouton de fermeture

- Poliéster pongee
- Repelente de água
- Peso 150 g
- Botão Fechar



Cape de coupe EUROSTIL Capa corte EUROSTIL



u.m.vta: 1  40 

REF.06989

- Polyester pongé
- Hydrofuge
- Poids 150 g
- Bouton de fermeture

- Poliéster pongee
- Repelente de água
- Peso 150 g
- Botão Fechar

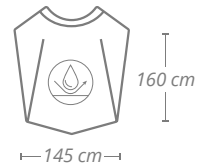

Cape de coupe RAGNAR
Capa corte RAGNAR

RAGNAR
 BARBER LINE

u.m.vta: 1  40

NEW

American Old School
 REF. 07517



07517

Graffiti
 REF. 07518



07518

Aviator classic color
 REF. 07519



07519

Aviator classic
 REF. 07520



07520

Dolar american flag
 REF. 07521





07521



Fermeture à crochet
 Fecho de gancho

Cape rayée Polo Barber

Capa listrada de Polo Barber

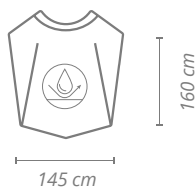

u.m.vta: 1  40 

REF.06991



Cape à rayures tête de mort

Capa de tarja de caveira

u.m.vta: 1  40 

REF.06993

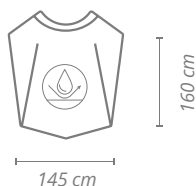



- Polyester pongé
- Hydrofuge
- Poids: 150 grammes
- Fermeture: crochets

- Poliéster pongee
- Repelente de água
- Peso: 150 gramas
- Encerramento: Ganchos

Cape d'ustensiles

Camada de utensílios

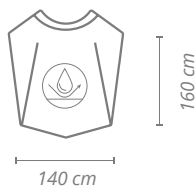

u.m.vta: 1  40 

REF.06995



Cape rayée blanc-noir

Capa listrada branco-preta

u.m.vta: 1  40 

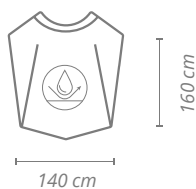

REF.06992



- Polyester pongé
- Hydrofuge
- Poids: 150 grammes
- Bouton de fermeture

- Poliéster pongee
- Repelente de água
- Peso: 150 gramas
- Botão Fechar

Cape de coupe BARBER SHOP
Capa corte BARBER SHOP

u.m.vta: 1  40 

REF.06997

- Polyester pongé
- Hydrofuge
- Poids: 150 grammes
- Bouton de fermeture

- Poliéster pongee
- Repelente de água
- Peso: 150 gramas
- Fecho de botão

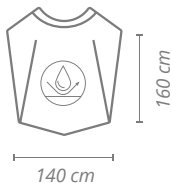

Cape de coupe EUROSTIL
Capa corte EUROSTIL

u.m.vta: 1  60

REF.04577

- Modèle: tête de mort
- 100% Nylon
- Bouton de fermeture

- Modelo skull
- 100% Nylon
- Fecho de botão

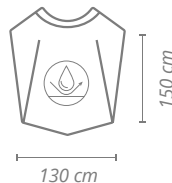

Sac 30 capes noires
Bolsa 30 capas pretas

u.m.vta: 1  50

Usage unique.
Uma só utilização

REF. 07243

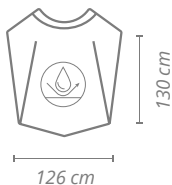

Cape de coupe
Capa corte

u.m.vta: 1  12

Grande. Velcro
Grande. Velcro

REF. 01174

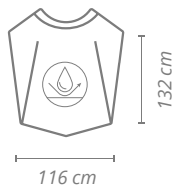



Tablier en jean avec poches Avental de ganga com bolsos

u.m.vta: 1  10 

REF. 07010

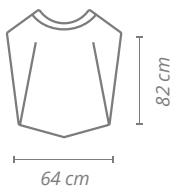
- Poids: 200 grammes
- Peso: 200 gramos



u.m.vta: 1  10 

REF. 07057

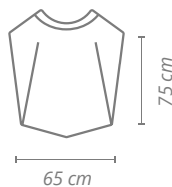
- Poids: 200 grammes
- Noir avec et détails en cuir synthétique.
- Peso: 200 gramos
- Preto com detalhes em imitação de pele.



Tablier bleu BARBER LINE Avental BARBER LINE apron



u.m.vta: 1  10 

REF. 07058

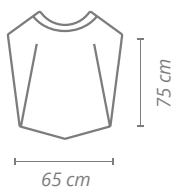
- Poids: 200 grammes
- Marqué du logo Barber Line
- Peso: 200 gramos
- Marcada con el logo Barber Line



Tablier barber line Avental line apron

u.m.vta: 1  60 

REF. 06182

- 3 poches 1 en haut, 2 en bas
- 6 compléments, 1 supérieur et 5 inférieurs
- 3 bolsos, 1 superior, 2 inferior
- 6 complementos, 1 superior e 5 inferior





Cape de coupe CAPTAIN COOK

Capa corte CAPTAIN COOK

u.m.vta: 1  12

100% Nylon
100% Nylon

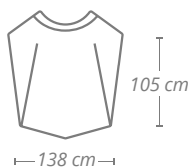

 **REF.04975/50**

 **REF.04975/58**



Tablier CAPTAIN COOK

Avental COOK APRON

u.m.vta: 1  60 

3 pochess 1 en haut, 2 en bas
6 compléments, 1 supérieur et 5 inférieurs
3 bolsos, 1 superior, 2 inferior
6 complementos, 1 superior e 5 inferior

REF. 06181

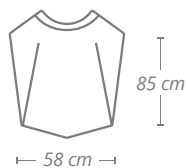

Cape à rayures pour barbier Capa listrada para barbeiro

u.m.vta: 1  40

MOD. 21800976

REF. 06351

Cape barber pole Capa de pólo de barbeiro

u.m.vta: 1  40

MOD. 21800974

REF. 06353

Cape de camouflage grise Capa de camuflagem cinza

u.m.vta: 1  40

MOD. 21800975

REF. 06352



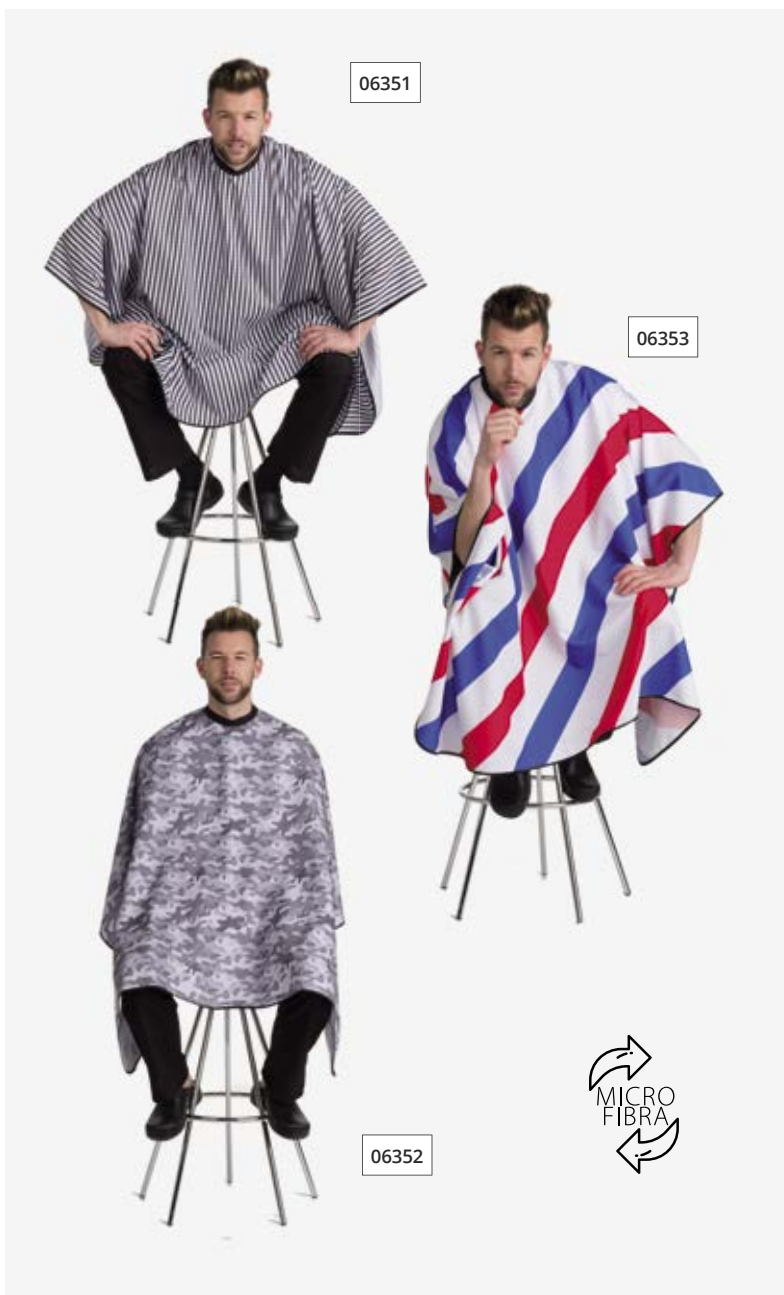

06351



06353

06352



Largueur
Largura

Longueur
Longo

131/132 cm 
143/144 cm 

- 100% polyester fin
- Fermeture crochets.
- Facile à repasser.
- Ne déteint pas. Antistatique.

- 100% fino polyester
- Com grampos de suportes de pressão.
- Aantistático.

Casaque col mao Casaco de gola mao

u.m.vta: 1 40

MOD. 51805305

REF.06357/50/3

L

118-122 cm

120-124 cm

74-76 cm

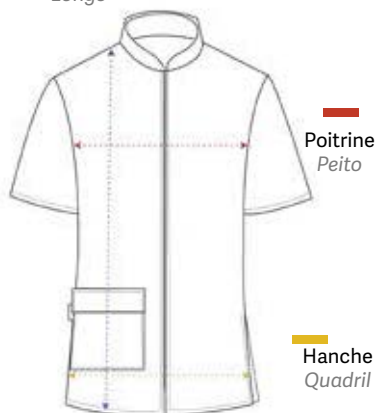
Longueur
Longo

Poitrine
Peito

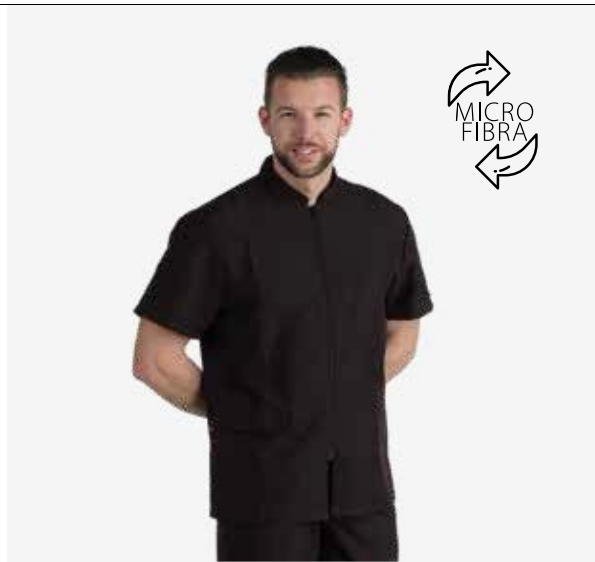
Hanche
Quadril

Col Mao avec fermeture à éclair YKK. Poches avec rabas anti-cheveux. Facile à repasser ne déteint pas. Antistatique. 100% polyester fin

Gola Mao com zíper YKK. 100% fino polyester

Tablier en polyester Avental de poliéster

u.m.vta: 1 40

MOD. 31803151

REF.06350

28/29 cm

66/67 cm

81,50/82,50 cm

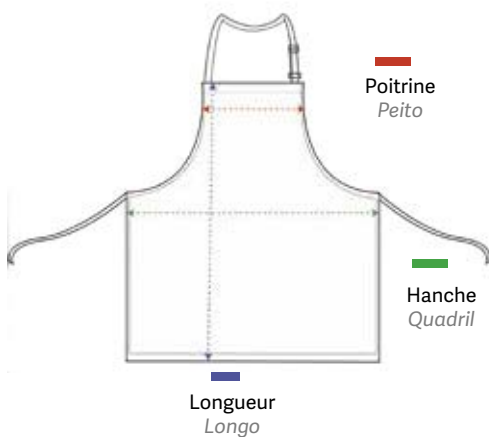

Poitrine
Peito

Hanche
Quadril

Longueur
Longo

Tablier cuir. Sans poches. Imperméable. Courroie ajustable pour le cou.. Skai

Avental de couro liso. Sem bolsos impermeável. Com regulador no pescoço. Couro

Tablier denim rétro Avental retro em jeans

u.m.vta: 1  40

MOD. 31803155

REF.06355

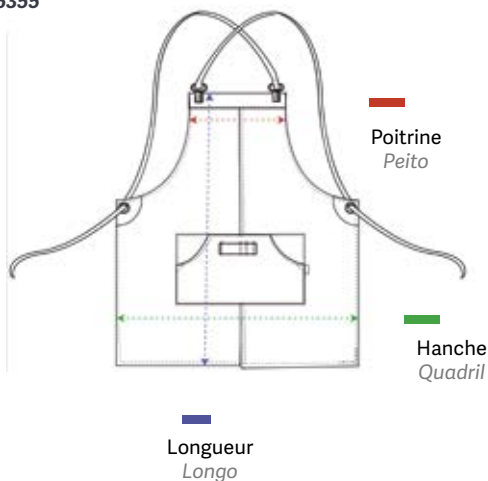
 27/28 cm 69/70 cm 81/82 cm

- Tablier rétro en jean élastique avec skai marron. Poche centrale. Bretelles ceinture lacet ajustable pour la taille.
- 60% polyester, 37% coton, 3% élastique

• Denim elástico avental com detalhes de couro falso marrom. Bolso central com aplique de utensílio. Grampos reguladores cruzados nas costas. Corte central.

• 60% polyester, 37% algodão, 3% elástico

Tablier Denim Avental jeans

u.m.vta: 1  40

MOD. 31603125

REF. 06310/50

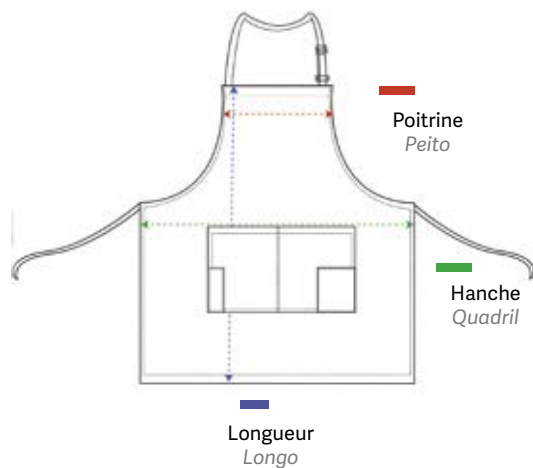
 25/26 cm 82/83 cm 81,50/82,50 cm

- Tablier denim.Ceinture lacet pour la taille. 4 poches (poche centrale divisée en 2 + 2 petites)
- 60% polyester, 37% coton, 3% élastique

• Avental de denim elástico bib. Regulamento com cinta e fecho de loop. Com 4 bolsos (bolso central dividido em 2 + 2 pequenos)

• 60% polyester, 37% algodão, 3% elástico

Pantalon unisexe

Calças unisex

u.m.vta: 1  40

MOD. 41300904

- Pantalon en polyester avec 3 poches.
- Facile à repasser ne déteint pas.
- 100 % polyester fin.

- Calças finas de poliéster com 3 bolsos.
- Cintura ajustável com cordão.
- Antiestático.
- 100 % fino polyester



S

- 96-96 cm
- 92-96cm
- 99-101 cm

REF.06356/1

M

- 102-106 cm
- 104-108cm
- 107-109 cm

REF.06356/2

L

- 110-114 cm
- 110-114 cm
- 107-109 cm

REF.06356/3

XL

- 112-116cm
- 114-118 cm
- 108-110 cm

REF.06356/4

Longueur
Longo

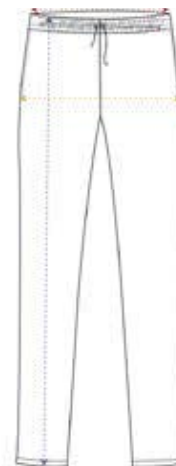

Taille
Cintura

Hanche
Quadril



Spray barber 12 couleurs

Sprays de barbeiro 12 cores

u.m.vta: 1  10 

280 ml

REF.07000

- 6 ambres + 3 transparents + 3 gris
- Matière plastique
- Poids: 86 grammes

- 6 ambar + 3 transparentes + 3 grises
- Material plástico
- Peso: 86 gramos



07000



07002



06998



25 cm

6,5 cm

06999





24,5 cm

7,5 cm

Spray barber calavera 12 couleur

Sprays de barbeiro 12 cores

u.m.vta: 1  10 

500 ml



REF.07002

- Avec pulvérisateur japonais
- Matériel: plastique
- Poids: 101 grammes
- 6 ambres + 6 noirs

- Con pulverizador japonés
- Material: Plastico
- Peso: 101 Gramos
- 6 ambar + 6 negras

Spray barber 12 couleurs

Sprays de barbeiro 12 cores

u.m.vta: 1  10 

500 ml

REF.06998



- 6 ambres + 3 transparents + 3 gris
- Matière plastique
- Poids: 76 grammes

- 6 ambar + 3 transparentes + 3 grises
- Material plástico
- Peso: 76 gramos



Spray barber 12 couleurs

Sprays de barbeiro 12 cores

u.m.vta: 1  10 

650 ml



REF.06999

- 6 ambres + 3 transparents + 3 gris
- Matière plastique
- Poids: 86 grammes

- 6 ambar + 3 transparentes + 3 grises
- Material plástico
- Peso: 86 gramos

Pulvérisateur EUROSTIL

Pulverizador EUROSTIL

u.m.vta: 1  20 

30 ml

REF.07001

- Bouteille transparente avec pulvérisateur noir
- Matière: plastique
- Poids 45 grammes

- Botella transparente con pulverizador negro
- Material: Plástico
- Peso 45 gramos



Pulvérisateur

Pulverizador

u.m.vta: 1  12 

300 ml

REF.04731

- **Spray continu** : avec une seule pression, il pulvérise l'eau de manière fine et uniforme, avec la même pression du début jusqu'à la dernière goutte
- **360°** : il peut être utilisé depuis tous les angles, y compris la tête en bas. Pulvérisation fine, type brume, qui distribue l'eau de manière uniforme sur tous les cheveux
- **Capacité** : 300 ml rechargeable
- **Volume fixe de pression** : 1,25 cc continu
- **Évite la fatigue de la main** par rapport à d'autres spray standards
- **Sans gaz contaminant**



300 ml

REF.04978

- **Spray contínuo**: com uma só pressão no gatilho, pulveriza a água de maneira fina e uniforme com a mesma pressão da primeira até à última gota
- **360°** Pode usar-se a partir de todos os ângulos, incluindo boca abaixo
- **Pulverização fina tipo neblina** que distribui a água de maneira uniforme sobre o cabelo todo
- **Capacidade**: 300 ml enchimento
- **Volume fixo de pressão**: de 1,25 cc contínuo
- **Evita a fadiga da mão** em comparação com os sprays standards.
- **Sem gases contaminantes**

RAGNAR
BARBER LINE



300 ml

REF.06243



Pulvérisateur BARBER LINE
Pulverizador BARBER LINE

Barber Line



u.m.vta: 1  35 

D'aluminium
 Alumínio

280 ml

REF.04837



u.m.vta: 1  12 



Talc
 Talco

180 ml

REF.06118



Pulvérisateur talc classique BARBER LINE
Pulverizador clássico talco BARBER LINE

u.m.vta: 1  12 

180 ml

REF.06179





u.m.vta: 1  12

180 ml

REF.06178



Pulvérisateur d'aluminium Pulverizador alumínio

u.m.vta: 1  35 

Intérieur laqué
Interior lacado

Neutre
Neutro

280 ml

280 ml

REF.01384

REF.01384/02



Présentoir de 30 pulvérisateurs d'aluminium Expositor 30 pulverizadores alumínio

u.m.vta: 1  1

Eurostil
Eurostil

Neutre
Neutro



280 ml

280 ml

REF.01465

REF.01465/02



Pulvérisateur en plastique Pulverizador de plástico

u.m.vta: 1  180 

Avec pendentif
Com suspensão

130 ml

REF.03401

u.m.vta: 1  24 

Diffuseur noir japonais
Difusor preto japonês

300 ml



REF.04377



Sac à dos - Valise pour barbiers Mochila - Mala para barbeiro

u.m.vta: 1  4

REF.06797



- 4 grands compartiments avec fermeture zippée
- Il a des compartiments intérieurs plus spéciaux pour les machines et les ustensiles.
- Matière: simili cuir polyester
- Clip sur les poignées avec clip

- 4 compartimentos grandes com fecho de correr
- Possui compartimentos interiores mais especiais para máquinas e utensílios.
- Material: poliéster de couro Simile
- Grampo nas alças com grampo

Valise noire pour coiffeur Mala de barbeiro cor preta

u.m.vta: 1  12

REF.06438



Valise trolley pour coiffeur en SKAI (vide) Mala trolley pele ecológica Cabeleireiro (Vazia)

Toutes les valises sont vendues vides
Todas as malas são vendidas vazias

u.m.vta: 1  1

REF.04308



REF.06136



- 3 grands compartiments avec 2 plateaux au sommet avec des trous pour mettre les ustensiles
- 4 roues pour le déplacer facilement et facilement!
- Avec roues amovibles

- 3 grandes compartimentos com 2 bandejas no topo com furos para colocar utensílios
- 4 rodas para movê-lo com facilidade e facilidade
- Com rodas removíveis

Valise trolley 4 compartiments

Mala 4 corpos

u.m.vta: 1  1

REF.04943

Double valise en nylon équipée de roues. Bête peut être utilisée séparément avec bandoulière. Deux compartiments intérieurs qui peuvent être aménagés. Offre beaucoup d'espace de rangement. Intérieur plastifié facile à nettoyer. Grande poche extérieure. Équipée de roues. Son intérieur est également plastifié. Livrée avec un porte-pinceaux cosmétiques fixé au moyen d'un velcro qui peut être déplacé. Elle est équipée de 8 compartiments intérieurs amovibles pour ranger les produits. Une poche extérieure sur chaque côté. La position des deux valises peut être inversée.

Mala de nylon dupla com rodas. A parte superior pode ser convertida em uma bolsa de mão, que vem com uma alça para pendurar no ombro. Tem duas bandejas internas que podem ser movidas para os lados, o interior é largo e a parte inferior é removível e está plastificada para facilitar a limpeza da mala. Também na parte de trás tem um bolso externo. A parte de baixo com rodas tem a parte interior plastificada e é removível para facilitar a limpeza, vem com um porta-escovas que é preso por um velcro. Este portaescovas pode ser trocado entre a parte superior e inferior. Tem 8 gavetas para armazenar e separar pequenos produtos. Tem um bolso de cada lado. Cada coluna inteira 4 gavetas que estão unidas em uma única peça são removíveis.



Sac de coiffure avec roues

Trolley cabeleireiro com rodas

u.m.vta: 1  1

REF.04402/50

Trousse à maquillage (vide) incluse dans
Necessaire (vazio)
incluido na



- Avec la structure métallique qui permet d'utiliser la valise comme siège
- Com estrutura metálica que permite usar a MALA como assento

Valise trolley

Trolley

u.m.vta: 1  1

REF.03814/50



Valise pour coiffure en aluminium



Malas alumínio cabeleireiro

u.m.vta: 1  1

REF.04307

(Vide)
(vazia)

Sachet 75 serviettes CELLULOSE
Pacote 75 toalhas CELULOSE

u.m.vta: 1  16 



50 g/m²

- Spéciales manucure
- Especial manicure

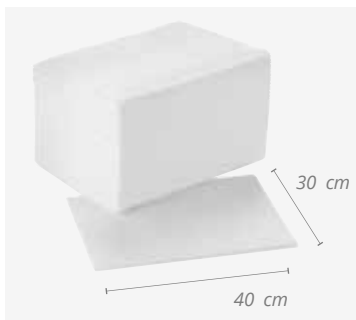
REF. 04204





Sachet de 25 serviettes SPUNLANCE
Pacote 25 toalhas SPUNLANCE

u.m.vta: 1  24 

50 g/m²

40 x 90 cm

REF. 04916

u.m.vta: 1  28 

50 g/m²

40 x 80 cm

REF. 03221

- Plié à 20 x 20 cm
- 50% Polyester / 50% viscose

- Dobrado a 20 x 20 cm
- 50% poliéster / 50% Viscose



Sachet 90 Serviettes CELLULOSE
Pacote 90 Toalhas CELULOSE



u.m.vta: 4  144 

55 g/m²

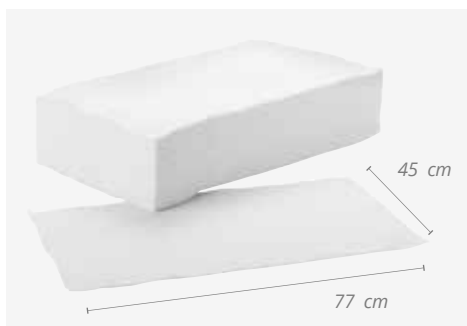
REF.04076



Sachet 100 Serviettes SPUNLANCE
Pacote 100 toalhas SPUNLANCE



u.m.vta: 4  20 

REF. 03283

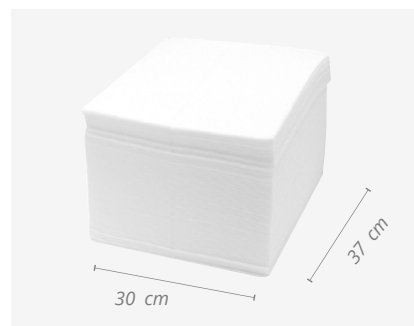
- Super absorbantes
- Superabsorventes.



Sac sachet de 25 serviettes SPUNLANCE
Bag pacote 25 toalhas SPUNLANCE



u.m.vta: 1  28 

50 g/m²

REF. 07233



Sachet de 35 serviettes SPUNLANCE
Pacote 35 toalhas SPUNLANCE

u.m.vta: 1  12 

50 g/m²



REF. 04509

- Super absorbantes.
- Serviettes pliées

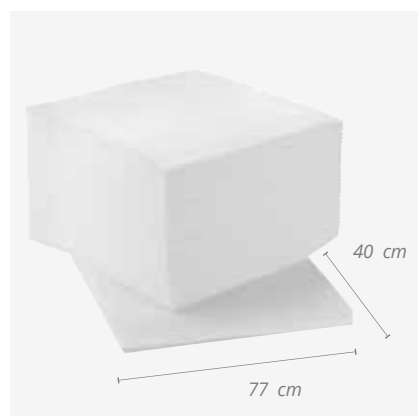
- Superabsorventes
- Toalhas dobradas.



Serviette 100% coton
Toalha 100% algodão

u.m.vta: 12  48 

380 g/m²

REF. 02947/50



REF. 04953/50

- Résistant à l'eau de Javel
- Lixívia resistente



380 g/m²

REF. 02901/50





380 g/m²

REF. 06829/50

- Résistant à l'eau de Javel
- Lixívia resistente



Serviette salon de coiffure 100% coton
Toalha barbearia 100% algodão



u.m.vta: 12  48 

380 g/m²

REF. 06413/50



100 Gants pe jetables pour une hygiène irréprochable 100 Lúvas pe descartáveis para higiene impecável

u.m.vta: 1  25 

REF. 07257

- Ambidextre permet à chaque gant d'être utilisé pour n'importe quelle main
- Taille unique
- Multi usage
- *Ambidestro permite que cada luva seja usada para qualquer mão*
- *Tamanho único*
- *Multiuso*



100 Gants en polyéthylène transparent 100 Luvas transparentes de polietileno

u.m.vta: 100  100

REF. 07804

- 100% Polyéthylène vierge pehd 0,7 +/- 2% g / pc
- Hypoallergénique, étanche, taille unique
- Epi catégorie 1, fabriqué et marqué CE
- Compatible avec l'usage alimentaire 2011/10 / CE
- 30 Cm. Hauteur x 25 cm. Largeur des doigts x 15 cm. Largeur du poignet
- *Polietileno hdpe 100% 0,7 +/- 2% g / pc*
- *Analérgico, impermeável, um tamanho*
- *Categoria 1 epi, produtos e marcações CE*
- *Compatível com uso de alimentos 2011/10 / CE*
- *30 Cm de altura x 25 cm de largura x 15 largura do pulso*



Sachet de 100 gants jetables Saco de 100 luvas descartáveis

u.m.vta: 1  100 

REF. 07304



Boîte contenant 20 gants noirs en latex
Caixa 20 luvas látex cor preto

LATEX / LATEX
 AQL 1,5

u.m.vta: 1  24 

S

REF. 02832

M

REF. 02833

L

REF. 02834

Conforme à la norme / Cumprem a norma: EN 374-1, EN 374-2, EN 374-3, CE





PAS de poussière
 SEM pó



Boîte contenant 100 gants noirs en nitrile
Caixa 100 luvas nitrilo pretas

NITRILE / NITRILU
 AQL 1,5

u.m.vta: 1  10 

S

REF. 06686

M

REF. 06687

L

REF. 06688

Conforme à la norme / Cumprem a norma: EN 374-1, EN 374-2, EN 374-3, CE



PAS de poussière
 SEM pó



Présentoir ciseaux en méthacrylate
Expositor tesouras metalicrato

u.m.vta: 1  20

REF.04074



conteneur pour ciseaux
Recipiente para tesoura

u.m.vta: 1  24

REF.04740



Porte carte de visite
Porta-cartoes em aluminio

u.m.vta: 1  400

REF.02470









Ceinture porte-outils
Cinturão porta-utensílios

u.m.vta: 1  48



REF.04310







Toutes les Porte-outils sont vendues vides
 Todas as Porta-utensílios são vendidas vazias

Porte-outils**Estojo ferramentas porta-utensílios**u.m.vta: 1  48**REF.03622**A vec 5 combinables (vide)
com 5 combinações (vazio)u.m.vta: 1  48**REF.03620**u.m.vta: 1  48**REF.03621****CAPTAIN COOK****CAPTAIN COOK**u.m.vta: 1  48Porte-outils
Estojo ferramentas**REF.04979**u.m.vta: 1  50Casquette noire
Chapeu cor preto**REF.07430**u.m.vta: 1  1T-shirt noir
T-shirt cor preto**S****REF.04957/4****M****REF.04957/1****L****REF.04957/2****XL****REF.04957/3**



Solution hydro-alcoolique
Solução hidroalcoólica

| | | | | | | |
|------------|---|----|---|------------|---|----|
| u.m.vta: 1 |  | 63 |  | u.m.vta: 1 |  | 23 |
| 100 ml | | | | 500 ml | | |
| REF.07176 | | | | REF.07177 | | |

| | | | | | | | |
|------------|---|---|---|---|---|---|---|
| u.m.vta: 1 |  | 7 |  | u.m.vta: 1 |  | 7 |  |
| 1 L | | | | Avec pompe de dosage Con bomba doseadora | | | |
| REF.07260 | | | | 1 L | | | |
| | | | | REF.07214 | | | |



Gel hydro-alcoolique à l'Aloe Vera
Gel hidroalcoólico com Aloe Vera

| | | | |
|------------|---|----|---|
| u.m.vta: 1 |  | 40 |  |
| 100 ml | | | |
| REF.07246 | | | |



Gel hidro-alcoholico
Gel hidroalcoólico

| | | | |
|------------|---|----|---|
| u.m.vta: 1 |  | 22 |  |
| 500 ml | | | |
| REF.07216 | | | |



Alcool 96°
Álcool 96°

| | | | |
|------------|---|----|---|
| u.m.vta: 1 |  | 12 |  |
| 1 L | | | |
| REF.07218 | | | |



Articles en vente exclusive en ESPAGNE
Artigos exclusivo de venda EM ESPANHA



Antiseptique daromix gh
Antiséptico daromix gh

u.m.vta: 1  12

1 L

REF.06200

Désinfectant au limoseptol
Desinfetante limoseptol

u.m.vta: 1  20 

50 ml

REF. 06151

u.m.vta: 1  20

1 L



REF.06150



- Numéro d'enregistrement AEMPS: 905-DE5
 - Antiseptique hydroalcoolique pour la désinfection hygiénique des mains par friction.
 - Efficacité scientifiquement garantie
 - Biocide à large spectre de 30 sec.
 - Formule hypoallergénique
 - Préserve l'hydratation de la peau
 - N'irrite pas la peau
 - Sèche rapidement
 - Efficace comme: Bactéricide · Levuricide · Virucide · Microbactéricide
- Número de registo AEMPS: 905-DE5
 - Anti-séptico hidroalcoólico para desinfeção higiénica de mãos por fricção.
 - Eficácia cientificamente garantida
 - Biocida de amplo espectro a partir de 30 seg.
 - Fórmula hipoalergénica
 - Preserva a hidratação da pele
 - Sem irritação na pele
 - Secar rapidamente
 - Eficaz como: Bactericida · Levuricida · Virucide · Microbactericida

- Numéro d'enregistrement AEMPS: 47-DE5
 - Produit de haut niveau développé exclusivement pour l'hygiène,
 - nettoyage et désinfection, pour les ustensiles professionnels de salon de beauté.
 - Action détergente - Large spectre
 - Biodégradable - Sans phosphates et sans formol
 - Efficacité germicide et SANITIZER contre: Bactéries, levures et champignons.
- Número de registo AEMPS: 47-DE5
 - Produto de alto nível desenvolvido exclusivamente para higiene,
 - limpeza e desinfeção, para utensílios profissionais de salão de beleza.
 - Ação detergente - amplo espectro
 - Biodegradável - sem fosfatos e sem FORMOLO
 - Eficácia germicida e SANITIZER contra: Bactérias, leveduras e fungos.

Bouteille spécial pour gel et solution hydro-alcoolique
garrafa especial para gel e solução hidroalcoólica

u.m.vta: 1  3 



Avec support mural
 Com suporte para a parede

300 ml

REF.07278



Grand bocal em verre pour produit de désinfection
Grande garrafa esterilizador

u.m.vta: 1  6 

1 L



REF.06141



- Idéal pour stériliser de petits ustensiles
- Matière: verre

- Ideal para esterilizar pequenos utensílios
- Material: vidro



Miroir Espelho

u.m.vta: 1  10 

Miroir noir
Espelho cor preto

●
REF. 02591/50





u.m.vta: 1  10 

Miroir TV
Espelho TV

●
REF. 00254/50



u.m.vta: 1  6 

REF. 01955/50 **Miroir carré avec poignée Noir**
*Espelho quadrado com pega
Bronco*



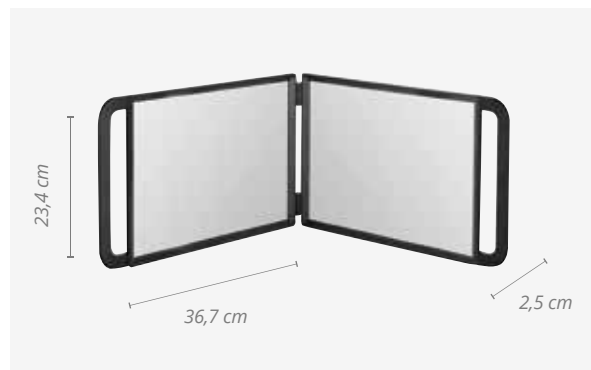

u.m.vta: 1  12

REF.04379 **Miroir double professionnel**
Espelho duplo profissional



Miroir noir en mousse EVA avec poignée
Espelho espuma EVA com pega cor preto

u.m.vta: 1  10 

REF. 02170



Tapete desinfetante de calçado Tapis désinfection pour semelles de chaussures

u.m.vta: 1  12

REF.07234

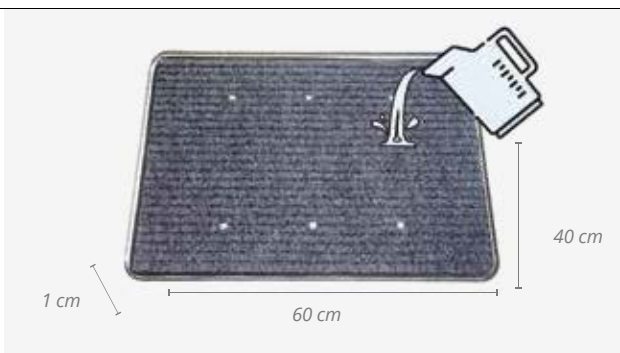



Tapis extra-plat de seulement 1 cm de hauteur pour éviter les chutes, fabriqué en polypropylène sur une base en caoutchouc et un conteneur en aluminium ionisé. Dimensions : 60 cm de largeur x 40 cm de longueur x 1 cm d'épaisseur/hauteur.

Mode d'emploi : placer le tapis sur une surface plane et nivelée, appliquer dans le plateau environ 700 ml de liquide désinfectant. Il est recommandé de placer un paillason après le plateau pour que le client puisse ensuite s'essuyer les pieds.

Tapete extraplano com apenas 1 cm de altura para evitar que alguém tropece em polipropileno sobre uma base de borracha e contendor de alumínio oxidado. Medidas: 60 cm largura x 40 cm profundidade x 1 cm altura/espessura

Como utilizar: colocar o tapete sobre uma superfície plana e nivelada aplicar na bandeja cerca de 700 ml de líquido desinfetante. Aconselhamos colocar um tapete fofinho à frente deste tapete para secar o calçado do cliente.

Lunettes de protection antibuée Tapete desinfetante de calçado

u.m.vta: 1  10 

REF.07256



- Protection pour prévenir les infections elles protègent efficacement des éclaboussures, des poussières, etc...
- Lieu d'utilisation : tous les endroits qui nécessitent une protection des yeux.
- Design innovant, confortable. Elles s'ajustent parfaitement à toute les formes et tailles de tête.
- Elles peuvent être utilisées en même temps que des lunettes de vue.
- Certificat CE
- Matière : plastique

- Proteção para prevenir infeções: protegem eficazmente contra salpicos, cascalho, etc.
- Local de utilização: qualquer lugar onde se requeira proteção para os olhos.
- Design inovador cómodo. Ajustam-se perfeitamente a qualquer forma e tamanho de cabeça.
- Podem-se utilizar por cima dos seus óculos graduados.
- Certificado CE
- Material: plástico

Sac 100 couvre-chaussures Embalagem 100 cobre-sapatos

u.m.vta: 1  50

REF.07211



À usage unique. Plastique
Uma só utilização. Plástico



Distributeur gel automatique mural avec plateau
Dispensador gel automático de pared com bandeja

u.m.vta: 1  12

1 L

REF.07271



Distributeur gel automatique de table
Dispensador gel automático de mesa

u.m.vta: 1  12

1 L

REF.07272



Distributeur automatique de gel mural avec support
Dispensador gel automático com pé

u.m.vta: 1  12

1 L

REF.07273



Distributeur mural manuel
Dispensador de parede manual

u.m.vta: 1  12

700 ml

REF.07274





Balais en caoutchouc Vassouras de borracha

u.m.vta: 4  16

Avec languette
Com aba

REF.01223



u.m.vta: 5  20 

REF. 01285/50



u.m.vta: 5  20

Fil espagnol et italien
Rosca espanhol e italiano

REF.02420



• Facile à nettoyer et durable, l'efficacité de la conception de ses pointes parvient à faire glisser la poussière sans la soulever, ce qui la rend idéale pour les personnes allergiques car elles favorisent un environnement propre.

• Fácil de limpar e duradoura, a eficácia do design de seus espigões consegue arrastar o pó sem levantá-lo, tornando-o ideal para quem sofre de alergias, pois favorece um ambiente limpo.

Manche à balai Punho vassoura

Fil espagnol et italien
Rosca espanhol e italiano

u.m.vta: 12  12

REF.01131

- Nettoyage facile et longue durabilité
- Support plastique
- Idéal pour tous les types de sols, en particulier le parquet

- Limpeza fácil e longa durabilidade
- Suporte de plástico
- Ideal para todos os tipos de pisos, especialmente parquet



u.m.vta: 10  10

REF.01365

- Extra télescopique
- Telescópico extra





09

Formation Formação

*Têtes malléable homme,
supports, tripieds...*

*Cabeça manequim
homem, suportes, tripé*

EURO *Stil*

PROFESIONAL

Têtes malléables homme 100% CHEVEUX NATURELS Cabeças manequins homem CABELO 100% NATURAL

Support inclus
Suporte incluído



u.m.vta: 1 10 10

- 42 implantations cm²
- 7-8 implants capillaires
- 320 cheveux env. au cm²
- Pour couper, décolorer, colorer, coiffures, séchage et lissage des cheveux
- Température maximum 180°C

- 42 Implantes por cm²
- 7-8 cabelos por implante
- 320 cabelo por cm²
- Para corte, descoloração, coloração, penteado, seco e com prancha
- Temperatura máxima 180°C

Châtain · Cor castanho

REF. 02495

- Implantation naturelle 45°
- Implantação natural 45°

Châtain avec barbe · Cor castanho com barba

REF. 02169

- Implantation naturelle 45°
- Idéale pour exercice de coupe et de taille de barbe
- Implantação natural 45°
- Também para corte de barba



Têtes malléables homme 100% CHEVEUX NATURELS

Cabeças manequins homem CABELO 100% NATURAL

u.m.vta: 1

10



- 42 implantations cm²
- 7-8 implants capillaires
- 320 cheveux env. au cm²
- Pour couper, décolorer, colorer,
- coiffures, séchage et lissage des cheveux
- Température maximum 180°C

- 42 Implantes por cm²
- 7-8 cabelos por implante
- 320 cabelo por cm²
- Para corte, descoloração, coloração, penteado, seco e com prancha
- Temperatura máxima 180°C

Châtain clair · Castanho claro

Joe

REF. 06147

- Implantation naturelle 45°
- Implantação natural 45°

**Joe**

REF. 04909

- Implantation classique 90°
- Implantação clássico 90°



Châtain clair avec barbe · Castanho claro com barba

Daniel

REF. 06148

- Implantation naturelle 45°
- Implantação natural 45°

**Daniel**

REF. 04908

- Implantation classique 90°
- Implantação clássico 90°



Supports tête malléable

Suportes cabeça manequim

u.m.vta: 1  25

REF. 00983





- Plastique
- Plástico

u.m.vta: 1  50

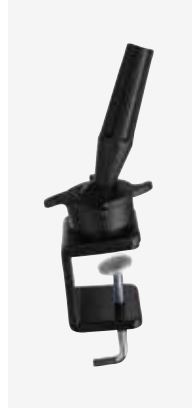
REF. 01461





- Plastique
- Plástico

u.m.vta: 1  100 

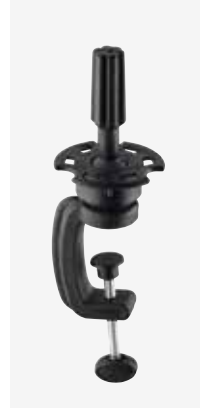
REF. 06276



- Plastique
- Plástico

u.m.vta: 1  10 

REF. 06162

9x10 units

- Plastique
- Plástico

u.m.vta: 1  12

REF. 03625

- Aluminium
- Alumínio





Support trépied de tête malléable

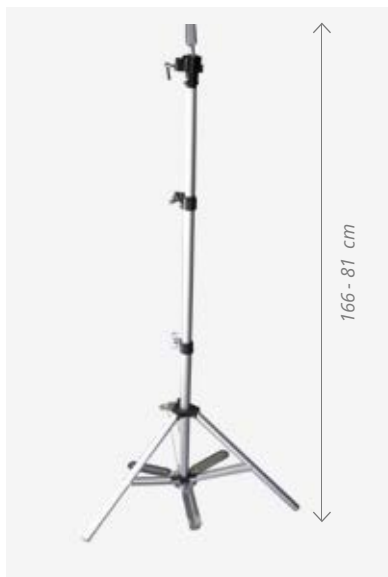

Suporte tripé cabeça manequim

u.m.vta: 1  10

REF. 03738

u.m.vta: 1  6

REF. 03624

u.m.vta: 1  6 

REF. 01841







C/Ciudad de Asunción 56 · Barcelona 08030 (Spain)
Tel. +34 93 274 07 84
ventas@eurostil.com · export@eurostil.com