

Pollié 
Pensando en el profesional

 **TASSEL**
SKIN COSMETICS

**Spezial
Schönheitsbehandlung
Speciale Estetica**

Keine Preise / Senza Prezzi

ANDREA
Pestarias

BEAUTENE

maniquick
Quality Treatment & Innovation

MEDISANA

promed



01 Linie Gesichtspflege Linea cura del viso 4

Reinigung und Vorbereitung der Haut	5
<i>Pulizia e preparazione della pelle</i>	
Crems und Behandlung, Ätherische Öle	8
<i>Crema e trattamenti, Oli essenziali</i>	
Inhalatoren und Zubehör · <i>Vaporizzatori e accessori</i>	23

02 Linie Körperpflege Linea per la cura del corpo 26

Crems und Behandlungen, basisöle	27
<i>Crema e trattamenti, oli base</i>	
Zubehör · <i>Accessori</i>	35

03 Haarentfernung Epilazione 36

Wachs kg · <i>Cera, formato KG</i>	37
Zubehör Wachs · <i>Accessori cera</i>	48
Wachs Format Roll-on · <i>Cera formato roll-on</i>	50
Zubehör Wachs-Roll-on · <i>Accessori per cera roll-on</i>	54
Zubehör Haarentfernung · <i>Accessori Epilazione</i>	57
Enthaarungspinzetten · <i>Pinzette depilatorie</i>	66

04 Maniküre und pediküre Manicure e pedicure 72

Nagellacke POLLIÉ · <i>Pollié nail polish</i>	73
Semi-permanenter Nagellack P-LACK	80
<i>Smalto semipermanente P-LACK</i>	
Acryl-Gel · <i>Acrylic gel</i>	82
Nagellackentferner ·	84
<i>Solvente per unghie</i>	
Gel- und Acryl-Pinsel · <i>Pennelli per gel e acrilico</i>	87
NAIL ART · <i>NAIL ART</i>	89
Lampen · <i>Lampade LED</i>	99
Paraffin · <i>Paraffina</i>	105
Nagelfräsern · <i>Micromotori</i>	107
Lupen · <i>Lenti d'ingrandimento</i>	116
Nagelfeile und Polierblöcke · <i>Lima e blocco per lucidare</i>	118
Sterilisator · <i>Sterilizzatori</i>	135
Nagelhautzange · <i>Tagliacuticole</i>	137
Nagelknipser für fingernägel · <i>Tagliaunghie</i>	142
Schieber · <i>Spingitori</i>	146
Accessoires Maniküre · <i>Accessori per manicure</i>	147
Haut- und Fingernagelscheren · <i>Forbici per pellicine e unghie</i>	148
Hautschieber	150
<i>Bastoncini arancio</i>	
Spezifische Pediküre · <i>Pedicure specifiche</i>	151

05 Make-up Trucco 162

Stifte, Eyeliner und wimpernmaske	163
<i>Matite, eyeliner e mascara</i>	
Abschminkschwämme · <i>Spugne struccanti</i>	168
Schwämme Make-up · <i>Spugne per il trucco</i>	169
Pinsel / Make-up-Pinsel	173
<i>Pennelli per il trucco</i>	

06 Wimpern Ciglia 188

Wimpern POLLIÉ · <i>Ciglia POLLIÉ</i>	189
Wimpern ANDREA · <i>Ciglia ANDREA</i>	195
Kits Wimpern, Strähnen und Haar für Haar	197
<i>Kit per ciglia, ciocche e pelo per pelo</i>	
Verkaufsträger, Wimpernkleber und Accessoires	199
<i>Espositori, colla per ciglia e accessori</i>	
Augenbrauen · <i>Sopracciglia</i>	201

07 Accessoires und hygiene Accessori e igiene 202

Abdeckungen und Papier für Kosmetikstuhl	203
<i>Fodere e carta coprilettino</i>	
Handtücher und Bettwäsche	204
<i>Asciugamani e lenzuola</i>	
Schutzausrüstung · <i>Protettori, Guanti</i>	207
Einmaliger Gebrauch · <i>Monouso</i>	211
Baumwolle · <i>Cotone</i>	218
Spiegel · <i>Specchi</i>	219
Hygienischen Gesichtsmasken · <i>Maschere facciali</i>	226
Kleidung / Uniformen · <i>Abbigliamento / uniformi</i>	228
Led ringleuchte · <i>Arco luminoso a led</i>	234
Koffer · <i>Valigie</i>	236
Pulverisatoren · <i>Spruzzini</i>	242
UV-Schutz · <i>Protettori UV</i>	243
Antiseptika und Desinfektionsmittel	244
<i>Antisetlici e disinfettanti</i>	

08 Mobiliar Complementi d'arredo 248

Kosmetikstühle · <i>Lettoni</i>	249
Maniküretisch · <i>Tavolo da manicure</i>	254
Wagens Maniküre/Pediküre	255
<i>Carrelli per manicure/pedicure</i>	
Wagens Maniküre/Pediküre	258
<i>Carrelli per manicure/pedicure</i>	
Handkoffer und Stühle de Make-up	263
<i>Valigie e sedie per il trucco</i>	

Die in diesem Katalog aufgeführten Preise sind empfohlene Preise, Steuern nicht inbegriffen.
Die Preise gelten bis auf Tippfehler.
Industrias Oriol 1942, S.L. behält sich das Recht vor, Änderungen ohne vorherige Ankündigung
vorzunehmen.

*I prezzi indicati in questo catalogo sono prezzi consigliati, IVA esclusa.
I prezzi saranno validi salvo errori tipografici.
Industrias Oriol 1942, S.L. si riserva il diritto di apportare modifiche senza preavviso.*



01

Linie Gesichtspflege Linea cura del viso

*Reinigung und Reparatur der Haut, Cremes
und Behandlung, Verkaufsträger, Zubehör...*

*Pulizia e riparazione della pelle, creme
e trattamenti, espositori, accessori...*



Mizellenwasser vs Reinigungsmilch Acqua micellare vs latte detergente



Für eine gute Gesichtereinigung sind eine Reinigungsmilch, die Hautverunreinigungen beseitigt, und ein Gesichtswasser, das neben seiner zusätzlichen Reinigungskraft auch desinfiziert und die Poren schließt, unverzichtbar. Das Gesichtswasser und die Reinigungsmilch Tassel enthalten hautschonendes Azulen. Alternativ kann auch Mizellenwasser verwendet werden. Dies reinigt schnell und ist sanft zur Haut. Unsere Produktpalette bietet eine große Auswahl, bei der Sie das für Sie passende Produkt finden werden.

Per una buona pulizia del viso è essenziale un latte detergente che rimuova tutto lo sporco e un tonico che pulisca i resti disinfettando e chiudendo i pori. Il latte e il tonico detergente Tassel contengono azulene, più delicato sulle pelli sensibili. È possibile inoltre utilizzare acqua micellare che consente di risparmiare passaggi nel processo di pulizia ed è delicata sulla pelle. Varie opzioni per purificare la tua pelle. Scegli il tuo prodotto!

Reinigungsmilch Latte detergente

u.m.vta: 1 12

500 ml

REF.07094



Revitalisierendes Gesichtswasser Tonifico rivitalizzante

u.m.vta: 1 12

500 ml

REF.07095



Arganöl und Aloe vera

Die Verwendung der Reinigungsmilch hilft, die Unreinheiten und die in der Haut angesammelten Schmutzreste zu entfernen. Auf diese Weise wird die Haut mit Sauerstoff versorgt, strahlt mehr und sieht gesünder aus. Mit Azulen für empfindliche Haut, fettet nicht. Für den täglichen Gebrauch.

Olio di argan e aloe vera

L'utilizzo del latte detergente aiuta a rimuovere le impurità e lo sporco accumulati nella pelle. In questo modo la pelle risulta ossigenata ed appare più luminosa e sana. Con azulene per pelli sensibili, non grassa. Per uso quotidiano.



Arganöl und Aloe vera

Die Verwendung des Gesichtswassers wirkt ausgleichend nach der Reinigung mit der Reinigungsmilch. Es ist der endgültige Schritt, um die Reinigung abzuschließen. Es verschafft der Haut Frische und Vitalität. Enthält Azulen, ideal für empfindliche Haut. Für den täglichen Gebrauch.

Olio di argan e aloe vera

L'utilizzo del tonico per il viso agisce come equilibrante dopo la pulizia con il latte detergente. È il passaggio finale per completarla. Dona freschezza e vitalità alla pelle. Contiene azulene, ideale per pelli sensibili. Per uso quotidiano.

Gesichtspeeling Esfoliante per il viso



u.m.vta: 1  15 

100 ml

REF.06071



Mizellenwasser Acqua micellare

u.m.vta: 1  9 

400 ml

REF.04206

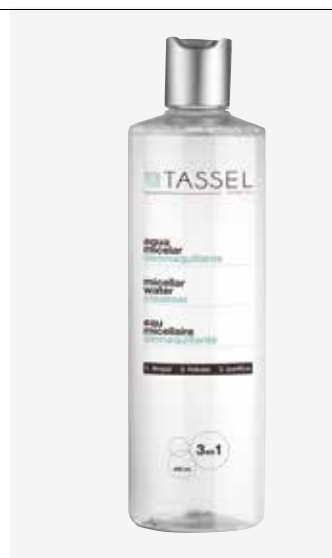



Natürliches mineralisches Peeling

Das Arganöl und die Aloe vera besitzen restrukturierende und regenerierende Eigenschaften. Der natürliche mineralische Wirkstoff besitzt großartige Eigenschaften für die Exfoliation. Er entfernt und beseitigt die abgestorbenen Zellen, ohne die Haut zu beschädigen. Die Haut wird sauber, sanft, strahlend und weist eine hohe Atmungsfähigkeit auf, was die Absorption bei jeder Schönheitsbehandlung begünstigt. Kann als übliches Gesichtspeeling verwendet werden.

Minerale naturale esfoliante

L'olio di argan e l'olio di aloe vera hanno proprietà ristrutturanti e rigeneranti. Il principio attivo minerale naturale ha grandi proprietà esfolianti. Elimina e rimuove le cellule morte senza danneggiare la pelle, lasciandola pulita, morbida, luminosa e con grande capacità respiratoria, favorendo l'assorbimento di qualsiasi trattamento estetico. Può essere usato come un normale scrub per il viso.

Black Mask Tiefenreinigung Black Mask pulizia profonda

u.m.vta: 1  12 

50 ml

REF.04580

Peel-off-Maske:

Das Produkt wird hauptsächlich auf der Grundlage einer sanften und effektiven Formel aus pflanzlicher Aktivkohle, Aloe vera, Hafer und pflanzlichem Glycerin hergestellt. Ermöglicht die Tiefenreinigung der Unreinheiten der Haut, ohne jede schädliche oder aggressive Wirkung auf die Haut.

Maschera peel-off:

Prodotto appositamente realizzato sulla base di una formula delicata ed efficace che contiene carbone vegetale attivo, aloe vera, avena e glicerina vegetale. Permette di pulire in profondità le impurità dalla pelle, senza alcun tipo di danno o aggressione.

Reinigt, belebt und hydratisiert

Mizellenwasser 3 in 1. Reinigt, entfernt Schminke und beseitigt Unreinheiten der Haut ohne Notwendigkeit des Ausspülens. Erhält das Feuchtigkeitsgleichgewicht und den pH-Wert der Haut und macht sie rein und sanft. Wirkt selbst bei widerstandsfähigem Make-up. Milder Rosenduft.

Deterge, tonifica e idrata

Acqua micellare 3 in 1. Deterge, rimuove il trucco e rimuove le impurità dalla pelle senza risciacquare. Rispetta l'equilibrio idrico e del pH della pelle, lasciandola pulita e levigata. Efficace con il trucco più duro. Delicato profumo di rose.



SCAN ME!



TASSEL SKIN COSMETICS bringt die Linie HYALURONIC auf den Markt
TASSEL SKIN COSMETICS lancia sul mercato la linea HYALURONIC

Die Hyaluronsäure ist eine strukturelle Komponente der extrazellulären Matrix der Haut, die zusammen mit dem Kollagen und den elastischen Fasern die Struktur der Dermis bilden, und sie ist damit beauftragt, die Haut hydratisiert zu halten. Eine mangelnde Hydratation kann kontraproduktive Auswirkungen auf unsere Dermis und Epidermis haben und macht die Haut empfindlicher für die Faktoren, die das Altern beschleunigen.

L'acido ialuronico è un componente strutturale della matrice extracellulare della pelle che, insieme al collagene e alle fibre elastiche, formano la struttura del derma cutaneo ed è responsabile del mantenimento dell'idratazione della pelle. Una mancanza di idratazione può produrre effetti controproducenti sul nostro derma e sull'epidermide, rendendo la pelle più sensibile ai fattori che ne accelerano l'invecchiamento.



Verkaufsträger verschiedene gesichtsmasken
Espositore hyaluronic (in regalo)

u.m.vta: 1  1

REF.07800

Enthält 2 Cremes mit Hyaluronsäure Ref. 06798 und 2 Seren mit Hyaluronsäure Ref. 06799.

Include 2 creme con acido ialuronico rif. 06798 e + 2 serum con acido ialuronico ref. 06799.



Creme hyaluronic

Crema hyaluronic

u.m.vta: 1



24



50 ml

REF.06798



Speziell für dehydrierte Haut. Aufgrund ihrer Zusammensetzung verdichtet sie die Haut erneut und verringert umgehend die Tiefe der Falten. Bekämpft die Gesichtsfältchen. Täglicher Gebrauch.

Eigenschaften:

- Hochgradig feuchtigkeitsspendend und befeuchtend
- Verbessert sichtbar die Lipidbarriere der Haut
- Stimuliert die Zellregeneration der Haut
- Mildert die Gesichtsfältchen, reduziert die Faltentiefe
- Füllt die feinen Linien und Falten der Haut auf

Anwendung: auf sauberer Haut sowohl im Gesichtsbereich als auch an Hals und Dekolleté mit sanften kreisenden Massagen anwenden, bis zur vollständigen Absorption. Kann Tag und Nacht angewandt werden, je nach den Erfordernissen der Haut.

Specifico per pelli disidratate. Per la sua composizione ridensifica la pelle, riducendo immediatamente la profondità delle rughe. Combatte le linee dell'espressione. Per uso quotidiano.

Proprietà:

- Altamente idratante e umettante
- Migliora visibilmente la barriera lipidica della pelle
- Stimola la rigenerazione delle cellule della pelle
- Leviga le linee dell'espressione, riducendo la profondità delle rughe
- Riempie le linee sottili e le rughe della pelle

Applicazione: applicare sulla pelle pulita della zona del viso, collo e scollatura con delicati massaggi circolari, fino al completo assorbimento. Può essere applicata giorno e notte a seconda delle esigenze della pelle.

Serum hyaluronic

Siero hyaluronic

u.m.vta: 1



12



30 ml

REF.06799

Faltenfüller. Anti-Aging-Effekt, dämmt die Auswirkungen des Alterungsprozesses ein und hält die Haut hydratiert, elastisch und strahlend.

Es handelt sich um ein hoch konzentriertes Hyaluronsäure-Serum, das hilft, die Haut zu rehydrieren und gegen Wasserverlust vorzubeugen. Es verstärkt zugleich Ihre Abwehrkräfte und verbessert spürbar Volumen, Festigkeit und Sanftheit der Haut. Anwendung: morgens und abends vor der Feuchtigkeitscreme auf sauberer und trockener Haut von Gesicht, Hals und anwenden. Bis zur vollständigen Absorption einmassieren.

Filler antirughe. Effetto antietà, contrasta gli effetti del passare del tempo, lasciando la pelle più idratata, elastica e luminosa. È un siero ad alta concentrazione di acido ialuronico che aiuta a reidratare la pelle e prevenire la perdita di acqua, rafforzandone le difese e migliorandone notevolmente il volume, la compattezza e la levigatezza.

Applicazione: applicare mattina e sera prima della crema idratante, sulla pelle pulita e asciutta di viso, collo e scollatura. Massaggiare fino al completo assorbimento





Feuchtigkeits-Tagescreme Crema da giorno idratante

u.m.vta: 1  1200

3 ml

REF.06653

Neue
Formel
Nuova
formula

u.m.vta: 1  24 

50 ml

REF.06451

200 ml

REF.07184

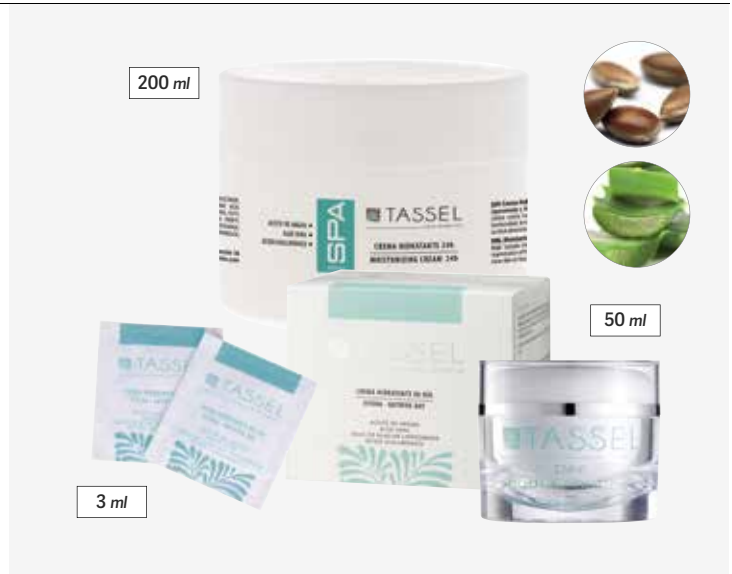

Hydro-nahrhaft day - Premium

Hydro-nährhafte Behandlung, die die Mechanismen der Haut stimuliert und wiederherstellt. Dank seiner Wirkstoffe: liposomiertes Gletscherwasser, Hyaluronsäure, Ceramide, Aloe vera und Arganöl, restauriert sie die natürliche Lipidbarriere der Haut und beugt gegen den Verlust von transepidermischem Wasser (TWEL) vor. Verbessert die Sanftheit, die Feuchtigkeitsbilanz und die Flexibilität der Haut.

Hidra-nutrive day - Premium



Trattamento idro-nutriente che stimola e ripristina i meccanismi della pelle. Grazie ai suoi principi attivi: acqua liposomiale di ghiacciaio, acido ialuronico, ceramidi, aloe vera e olio di argan, ripristina la naturale barriera lipidica della pelle, prevenendo la perdita di acqua transepidermica (TWEL). Migliora la levigatezza, l'equilibrio idrico e la flessibilità della pelle.

Nährstoffreiche Nachtcreme Crema da notte nutriente

u.m.vta: 1  1000

3 ml

REF.07297

u.m.vta: 1  24 

50 ml

REF.03541

200 ml

REF.07437



Arganöl und Aloe vera

Feuchtigkeitscreme, angereichert mit Arganöl und Aloe vera. Indiziert für jeden Hauttyp. Ihre Wirkstoffe stimulieren die Widerstandsfähigkeit der Zellen gegen freie Radikale und helfen bei der Regeneration der Dermis. Verschafft der Haut Leuchtkraft, Glätte und Festigkeit. Rasche Absorption. Täglich anwenden, vorzugsweise abends.

Olio di argan e aloe vera

Crema idratante arricchita con olio di argan e aloe vera. Adatta a tutti i tipi di pelle. I suoi principi attivi stimolano la capacità cellulare contro i radicali liberi e aiutano la rigenerazione del derma. Dona luminosità, levigatezza e compattezza alla pelle. Rapido assorbimento. Applicare quotidianamente, preferibilmente la sera.



Kaviar-Pflegecreme

Crema nutriente al caviale

u.m.vta: 1  1200

3 ml

REF.06654

u.m.vta: 1  18 

50 ml

REF.03543

u.m.vta: 1  12 

200 ml

REF.06452

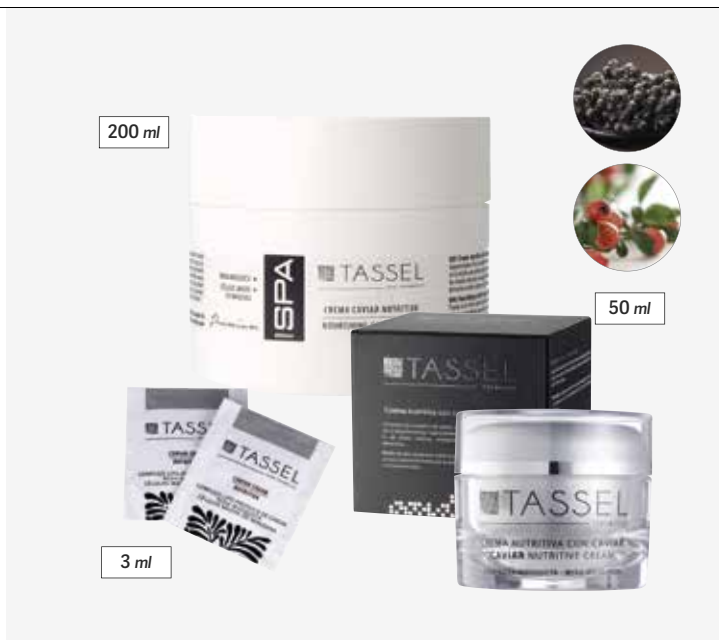



Lipoproteinkomplex mit Kaviar, reich an Vitaminen, Aminosäuren und Oligoelementen. Indiziert für dehydrierte und reife Haut, mit regenerierender Wirkung dank der Weinrose. Verhindert und mildert die Spuren des Alterns und von schädlichen Umwelteinflüssen. Rasche Absorption. Für bessere Ergebnisse vorzugsweise zweimal am Tag anwenden.

Complesso lipoproteico al caviale, ricco di vitamine, aminoacidi e oligoelementi. Indicato per pelli disidratate e mature, ad alto potere rigenerante grazie alla rosa mosqueta. Previene e ammorbidisce i segni del tempo e quelli causati dalle aggressioni esterne. Rapido assorbimento. Per risultati ottimali, applicare preferibilmente due volte al giorno.

Depigmentierende Creme E-Pigment

Crema depigmentante E-Pigment

u.m.vta: 1  24 

50 ml

REF.06800

Dafür konzipiert, um auf die dunkelsten Stellen des Gesichts zu wirken, die Produktion von Melanin zu stoppen und die Produktion von neuen Zellen zu stimulieren, die die Haut erneuern, so dass sie ihren normalen Ton wiedergewinnt. Angereichert mit Glycyrrhiza Glabra Root Extract, Kojisäure, Alphahydroxysäure.

- Reinigt und reduziert die Intensität von Flecken
- Erhöht die Leuchtkraft und homogenisiert den Hautton
- Verbessert die Hydratation und die Barrierefunktion der Haut
- Schützt die Haut vor Sonnenschäden und beugt gegen Flecken vor

Formulata essenzialmente per agire sulle zone più scure del viso, aiutando a fermarne la produzione di melanina e stimolando la generazione di nuove cellule che rinnovano la pelle, recuperando così il suo tono abituale. Arricchita con estratto di radice di glycyrrhiza glabra, acido cogico, alfa idrossiacidi.

- Schiarisce e riduce l'intensità delle macchie
- Aumenta la luminosità e uniforma il tono della pelle
- Migliora l'idratazione e la funzione di barriera della pelle
- Protegge la pelle dai danni del sole e previene la comparsa di macchie





Feuchtigkeitscreme mit Gold Crema idratante con oro

u.m.vta: 1  1200



3 ml

REF.06655

u.m.vta: 1  18 

50 ml

REF.04980

u.m.vta: 1  24 

200 ml

REF.07185



Gold und Weinrose

Indiziert für reife Haut, täglicher Gebrauch. Die natürlichen Oligoelemente stimulieren die Widerstandskraft der Zellen gegen freie Radikale, helfen bei der Regeneration der Dermis, wirken gegen Schläffheit und verschaffen der Haut Leuchtkraft, Glätte und Festigkeit. Emulgator der neuesten Generation: nicht ionisch, natürliches und PEG-freier Emulgator. Stark hydratierende Eigenschaften, verbessert sichtbar die Textur der Haut.

Gold: verstärkt die Leuchtkraft (ideal für fahle und sehr dunkle Haut), hat außerdem eine straffende und regenerierende Wirkung, die Haut sieht sichtbar jünger aus

Argirelox: dieses Peptid ist ein aktiver Inhaltsstoff, der Gesichtsfältchen bekämpft und die Muskelkontraktion der präsynaptischen Membrane vermindert

Pollushield: funktionaler Inhaltsstoff, der als eine Barriere zwischen der Haut und den Schadstoffen in der Umwelt wirkt und auch das Antioxidans-Potenzial der Haut erhöht.

Weinrose: natürliche Antifaltencreme, die die Produktion von Kollagen, Elastin und Hyaluronsäure fördert, welche der Haut Festigkeit und Elastizität geben

Oro e rosa mosqueta

Indicato per pelli mature, uso quotidiano. Gli oligoelementi naturali stimolano la capacità cellulare contro i radicali liberi, aiutano a rigenerare il derma, agiscono contro la flaccidità e donano luminosità, compattezza e alla pelle.

Emulsionante di ultima generazione: emulsionante non ionico, naturale e PEG-free. Notevoli proprietà idratanti e texture della pelle visibilmente migliorata.

Oro: esalta la luminosità (ideale per pelli spente e molto scure) ha anche un effetto tensore e rigenerante, pelle visibilmente più giovane

Argirelox: questo peptide è un ingrediente attivo che combatte le rughe di espressione attenuando la contrazione muscolare a livello pre-sinaptico.

Pollushield: ingrediente funzionale che funge da barriera tra la pelle e le sostanze inquinanti nell'ambiente e aumenta anche il potenziale antiossidante della pelle

Rosa mosqueta: antirughe naturale che favorisce la produzione di collagene, elastina e acido ialuronico, che donano compattezza ed elasticità alla pelle

Active cells · Anti-Aging · pflanzliche Stammzellen
Active cells · antietà · cellule staminali vegetali



Der Extrakt aus Stammzellen pflanzlichen Ursprungs verhindert und verlangsamt das frühzeitige Altern. Hilft bei der Stimulierung der Regeneration des Hautgewebes, dem er Festigkeit und Elastizität verleiht, und schwächt die durch den Alterungsprozess auftretenden Flecken und Falten ab. Serum von rascher Absorption wegen seiner leichten Textur. Das Serum vor der Creme anwenden und beide Produkte für ein wirksames Ergebnis verwenden.

Eigenschaften:

Anti-Aging-Wirkung, die den Prozess des Alterns verlangsamt und die Zellregeneration des Hautgewebes stimulieren. Reparatur der schädlichen Umweltwirkungen, besonders der Verschmutzung und der UV-Strahlung.

L'estratto di cellule staminali di origine vegetale previene e rallenta l'invecchiamento precoce. Aiuta a stimolare la rigenerazione del tessuto cutaneo, donandogli compattezza, elasticità e attenuando le macchie e le rughe prodotte dal passare del tempo. Siero a rapido assorbimento grazie alla sua texture leggera. Applicare il siero prima della crema e utilizzare entrambi i prodotti per un risultato più efficace.

Proprietà:

Anti invecchiamento e anti età, poiché rallenta il processo di invecchiamento e stimola la rigenerazione cellulare del tessuto cutaneo. Riparazione degli effetti nocivi dell'ambiente, in particolare dell'inquinamento e della radiazione UV.

Verkaufsträger für Tassel Active Cells
Espositore de Tassel Active Cells

u.m.vta: 1  1

REF.03926

Verkaufsträger bestehend aus:

5 Cremes Active · Cells Anti-Aging aus pflanzlichen Stammzellen (REF. 03702)



5 Seren Active · Cells Anti-Aging aus pflanzlichen Stammzellen (REF. 03703)

Espositore composto da:

- 5 creme antietà Active Cells con cellule staminali vegetali (RIF. 03702)
- 5 sieri antietà Active Cells con cellule staminali vegetali (RIF. 03703)



Crema Crema

u.m.vta: 1	 1200	u.m.vta: 1	 24	
------------	--	------------	--	---

3 ml

REF.06656

50 ml

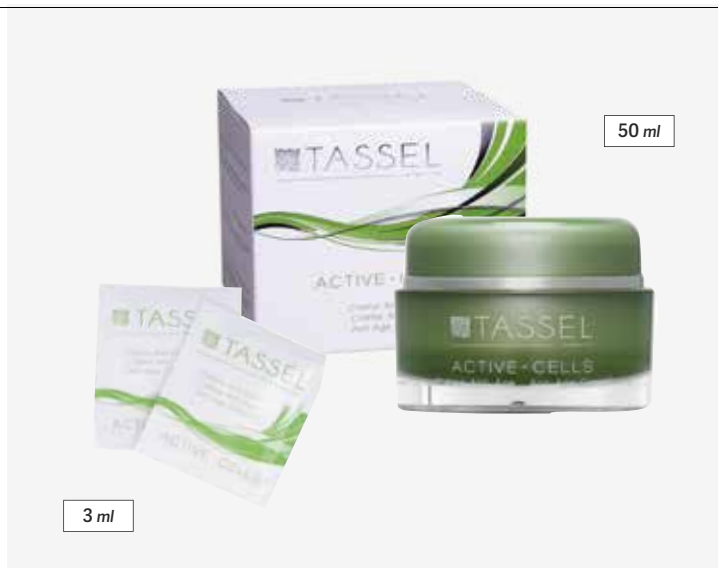

REF.03702



Halbflüssige Creme von rascher Absorption. Indiziert für reife Haut. Für eine wirksamere Behandlung nach dem Serum Verwenden. Der tägliche Gebrauch Tag und Nacht wird empfohlen.

Crema semifluida a rapido assorbimento. Indicato per pelli mature. Utilizzare dopo il siero per un trattamento più efficace. Si consiglia l'uso quotidiano giorno e notte.

Serum Eliianr Serum

u.m.vta: 1	 6	
------------	---	---

30 ml

REF.03703

Serum von rascher Absorption und leichter Textur. Das Serum vor der Creme anwenden. Für ein wirksameres Ergebnis beide Produkte anwenden. Täglicher Gebrauch.

Siero a rapido assorbimento grazie alla sua texture leggera. Applicare il siero prima della crema. Usa entrambi i prodotti per un risultato più efficace. Per uso quotidiano.





Verkaufsträger für Tassel Professional Line
Espositore della linea professionale Tassel

u.m.vta: 1		1
------------	---	---

REF.04664

Verkaufsträger für Cremes, bestehend aus:



- 3 Tagcremes Hydra-Nutrive (REF. 06451)
- 3 Nachtcremes Hydra- Nutrive (REF. 03541)
- 3 Feuchtigkeitscremes mit Gold (REF. 04980)
- 3 Pflegecremes mit Kaviar (REF. 03543)
- 6 Kollagen pur (REF. 07762)
- Sachets + Poster

Espositore per creme composto da:

- 3 creme da giorno Hydra-Nutrive (RIF. 06451)
- 3 creme da notte Hydra-Nutrive (RIF. 03541)
- 3 creme idratanti con oro (RIF. 04980)
- 3 creme nutrienti al caviale (RIF. 03543)
- 6 al collagene puro (RIF. 07762)
- Bustine + poster



Kollagen Collagene

u.m.vta: 1  6 

30 ml

REF.07762

Unmittelbare Wirkung

Kollagen-Konzentrat. Dank seiner festigenden Kraft und seiner Konzentration wird die Schläffheit des Gesichts schrittweise korrigiert, insbesondere in den Bereichen rund um Augen, Lippen, Hals usw. Täglicher Gebrauch. Schmiert nicht und wird schnell absorbiert. Täglich anwenden.

Effetto immediato

Concentrato di collagene. Grazie al suo potere rassodante e alla sua concentrazione, la flaccidità del viso viene gradualmente corretta, soprattutto nelle zone del contorno occhi, delle labbra, del collo, ecc. Uso quotidiano. Non unge e si assorbe rapidamente. Applicare quotidianamente.





Augenkontur Focus 3 Contorno occhi Focus 3

u.m.vta: 1  1200

3 ml

REF.06658

u.m.vta: 1  6 

30 ml

REF.03741



Crema mit frischer und leichter Textur, die bei der Reparatur der kleinen Falten der Augenkontur dank folgender Wirkstoffe hilft:

1. Vitamin C: antioxidierend, wirkt gegen freie Radikale

Kamille: beruhigend und abschwellend

Beta-Carotine: Anti-Aging-Effekt

2. Sorgt für Glätte, hilft bei der Bekämpfung von Tränensäcken, Augenringen und Anzeichen von Müdigkeit. Für den täglichen Gebrauch

Crema dalla texture fresca e leggera che aiuta a riparare le piccole rughe del contorno occhi grazie ai suoi principi attivi:

1. Vitamina C: antiossidante e anti-radicali liberi

Camomilla: lenitiva e decongestionante

Beta-caroteni: anti invecchiamento

2. Dona morbidezza, aiuta a combattere borse, occhiaie e segni di stanchezza. Per uso quotidiano.



SCAN
ME!

Reinigungsmousse T-PURITY Mousse detergente T-PURITY

u.m.vta: 1

12



200 ml

REF.06084



Ausgezeichnete talkregulierende, feuchtigkeitsspendende und spülende Eigenschaften für die Haut, mit denen das Make-up, die Unreinheiten und den Überschuss an Fett sanft entfernt werden, ohne die Haut zu reizen. Ihre flüssige Textur wird zu einem leichten, sanften Schaum, der für eine Tiefenreinigung sorgt, hydratiert und das Gleichgewicht der Haut verbessert. Sorgt für ein seidenmattes und samtiges Aussehen der Haut.

Segensreich aufgrund ihrer Wirkstoffe: feinere und reduzierte Poren, schattierter Glanz, sanftere und reinere Hauttextur, weiches und mattifiziertes Aussehen.

Eccellenti proprietà sebo-regolatrici, idratanti e balsamiche per la pelle che rimuovono delicatamente trucco, impurità e sebo in eccesso senza irritare la pelle. La sua texture liquida si trasforma in una schiuma leggera e morbida che fornisce una pulizia profonda, idratando e mantenendo l'equilibrio della pelle. Recupera un aspetto opaco e vellutato.

Grazie ai suoi principi attivi, apporta benefici: pori ridotti e più fini, lucentezza sfocata, texture della pelle levigata e purificata, aspetto levigato e opaco.

Adstringierende Creme T-PURITY Crema astringente T-PURITY

u.m.vta: 1

1200

3 ml

REF.06657

u.m.vta: 1

12



50 ml

REF.06086

Frisches Creme-Gel mit leichter Textur, speziell zubereiteten Wirkstoffen, die feuchtigkeitsspendend, talkregulierend und mattifizierend gegen das Glänzen wirken, das durch den Fettüberschuss auf der Haut entsteht. Minimiert Poren, schwarze Punkte und Mitesser. Ist mit pflanzlichen Wirkstoffen zubereitet, die die Lipidbarriere erneuern sowie entzündungshemmend, mattifizierend und talkregulierend wirken.

Crema-gel fresca e dalla texture leggera, formula con principi attivi idratanti, sebo-regolatori e opacizzanti della lucentezza causata dall'eccesso di sebo sulla pelle. Riduce al minimo i pori, i punti neri e i brufoli. Formula con principi attivi vegetali che agiscono come antinfiammatori, ristrutturanti della barriera lipidica, opacizzanti e sebo-regolatori.

Adstringierende fettige Hautlinie Linea astringente per pelli grasse

Gesichtswasser adstringierend T-PURITY Tónico astringente T-PURITY

u.m.vta: 1

12



200 ml

REF.06085



Adstringierendes Gesichtswasser, besonders für fettige Haut geeignet, regelt den Fettüberschuss, verhindert das Glänzen und hilft, Hautunreinheiten zu beseitigen.

Dank seiner Wirkstoffe schließt es die Poren, sorgt für einen seidenmatten und sanften Effekt auf der Haut und kontrolliert das Glänzen und das Fett auf der Haut. Bekämpft und verhindert Hautunreinheiten: regulierende Eigenschaften des Talgs, hilft, die Verbreitung von Bakterien zu kontrollieren und verhindert die Infektion der Poren, die zu Akne führen kann.

Tónico astringente per il viso, appositamente formulato per la pelle grassa, regola il sebo in eccesso, previene la lucentezza e aiuta ad eliminare le macchie.

Grazie ai suoi principi attivi, restringe i pori, aiuta a ottenere un effetto levigato e opaco sulla pelle controllando la lucentezza e il grasso sulla pelle. Combatte e previene le macchie: proprietà sebo-regolatrici, aiuta a controllare la proliferazione batterica, prevenendo l'infezione dei pori che causa l'acne.



50 ml

3 ml

Verkaufsträger aus Holz ätherischen Öle Espositore in legno oli essenziali

u.m.vta: 1	 1
------------	---

REF.04995

- Verkaufsträger aus Holz ätherischen Öle
 - 42 ätherischen Öle
 - 6 Modelle von 15 ml por jede referencia (x6)
 - 1 Modell von 30 ml por jede referencia (x6)
 - Geschenk 20 Broschüren
-
- 42 Oli essenziali
 - 6 modelli da 15 ml per ogni riferimento (x6)
 - 1 modello da 30 ml per ogni riferimento (x6)
 - In regalo 20 opuscoli



Verkaufsträger aus Holz ätherischen Öle Espositore in legno oli essenziali

u.m.vta: 1	 1
------------	---

Leer
Vuoto

REF.04995/01



Ätherische Öle Oli essenziali

Die meisten ätherischen Öle werden durch Destillation und Kaltpressung gewonnen; so erhält man eine Flüssigkeit, die die reine Essenz der Pflanze darstellt und es uns ermöglicht, alle ihre Eigenschaften zu nutzen.

La maggior parte degli oli essenziali si ottengono per distillazione e pressione a freddo, in questo modo è possibile ottenere un liquido che rappresenta la pura essenza della pianta e ci permette di godere di tutte le sue proprietà.

Ätherisches Süßorangenöl · Olio essenziale di arancia dolcequeta

u.m.vta: 1  6 

15 ml

REF.07752

Antioxidative und antimikrobielle Eigenschaften. Reduziert Falten, verbessert die Hautfestigkeit. Hilft bei der Bekämpfung von Cellulite und Flüssigkeitsansammlungen und reduziert die Flüssigkeitsstagnation. Ätherisches Orangenöl hat auch andere Verwendungen als Mückenschutzmittel.

Proprietà antiossidanti e antimicrobiche. Riduce le rughe, migliora la compattezza della pelle. Aiuta a combattere la cellulite e la ritenzione idrica, riducendo il ristagno di liquidi.

L'olio essenziale di arancia ha anche altri usi come repellente per zanzare.

30 ml

REF.07753

Ätherisches Zitronenöl · Olio essenziale di limone

u.m.vta: 1  6 

15 ml

REF.07754

Spendet Feuchtigkeit, nährt und repariert geschädigte Haut. Anti-Falten und Antioxidans Hellt fahle Haut auf. Fördert die Durchblutung, antiseptisch und adstringierend.



Idrata, nutre e ripara la pelle danneggiata. Antirughe e antiossidante Illumina la pelle spenta. Favorisce la circolazione sanguigna, Antisettico e Astringente.

30 ml

REF.07755

NEW



Ätherisches Bergamottenöl · Olio essenziale di bergamottolavandau.m.vta: 1  6 



15 ml

REF.07756

Entzündungshemmende, antibakterielle und antiseptische Eigenschaften (verhindert die Entwicklung von Mikroorganismen), Anti-Akne, Heilung.

Proprietà antinfiammatorie, antibatteriche e antisettiche (impedisce lo sviluppo di microrganismi), anti-acne, cicatrizzante.

30 ml

REF.07757**Ätherisches Salbeiöl · Olio essenziale di salvia**u.m.vta: 1  6 



15 ml

REF.07758

Für alle Hauttypen, reguliert den Talg der Haut und strafft sie. Antiseptische Eigenschaften, die das Wachstum von Mikroorganismen verhindern. Dies hilft bei verschiedenen Arten von Hautproblemen wie Ekzemen oder Läusen
Verhindert Trockenheit der Kopfhaut und beugt Haarausfall vor.

*Per tutti i tipi di pelle, regola il sebo della pelle e la tonifica. Proprietà antisettiche, prevenendo la crescita di microrganismi. Questo aiuta con diversi tipi di problemi della pelle, come eczema o pidocchi
Previene la secchezza del cuoio capelluto e aiuta a prevenire la caduta dei capelli.*

30 ml

REF.07759**Ätherisches Ylang-Ylang-Öl · Olio essenziale di ylang-ylangueta**u.m.vta: 1  6 

15 ml

REF.07760

Antiseptisch, antimikrobiell und entzündungshemmend Verbessert das Erscheinungsbild der Haut und regeneriert sie nach Veränderungen wie Ekzemen, Dermatitis oder Akne. Verbessern Sie die Durchblutung und stimulieren Sie die Zellerneuerung. Es fördert die Durchblutung und entgiftet die Haut, wodurch Cellulite weniger sichtbar wird.

Antisettico, antimicrobico e antinfiammatorio, migliora l'aspetto della pelle, rigenerandola dopo aver subito alterazioni come eczemi, dermatiti o acne. Migliora la circolazione sanguigna, stimolando il ringiovanimento cellulare. Aiuta la circolazione e disintossica la pelle, rendendo la cellulite molto meno visibile.

30 ml

REF.07761**NEW**

u.m.vta: 1



6



15 ml

REF.06044

Ätherisches Öl Lavendel · Olio essenziale di lavanda

Dies ist ein natürliches Antibiotikum und ein Antiseptikum mit heilender Wirkung. Entwässert und bekämpft die Cellulite, hilft, die Knoten unter der Haut zu beseitigen und ist ein großartiges Antiseptikum. Wirkt effektiv gegen Mikroorganismen wie Bakterien und Pilze. Entzündungshemmend, bekämpft Hautprobleme wie die Akne. Hilft auch, die Dermis nach Sonnenbrand zu regenerieren, da es den Zellstoffwechsel aktiviert. Der Lavendel trägt zur aktiven Regeneration des Gewebes bei, um die Haut jünger zu erhalten. Sorgt für zusätzliche Hydratation. Einige Tropfen dieses Öls können auch bei jeder anderen Gesichts- oder Körperbehandlung angewandt werden.

30 ml

REF.06049

È un antibiotico naturale e un agente antisettico e curativo. Drena, combatte la cellulite, aiuta a diluire i noduli sottocutanei ed è un ottimo antisettico. Agisce efficacemente contro i microrganismi batterici e fungini. Antinfiammatorio, combatte i problemi della pelle come l'acne. Aiuta anche a rigenerare il derma dopo le ustioni, poiché attiva il metabolismo cellulare. La lavanda contribuisce alla rigenerazione attiva dei tessuti per mantenere la pelle più giovane. Fornisce idratazione extra. È possibile anche applicare alcune gocce di questo olio in qualsiasi trattamento per viso o corpo.

15 ml

REF.06052

Ätherisches Öl Weinrose · Olio essenziale di rosa mosqueta

Regeneriert der Haut hervorragend. Wirkt oberflächlich als natürlich befeuchtender Faktor und verbessert die Hydratation. Nährt und regeneriert, schwächt Narben und Falten sichtbar ab. Korrigiert und verhindert Hautprobleme aufgrund von Lichtalterung, mit Hilfe der Selbsterzeugung von Melanin. Um Striemen während der Schwangerschaft zu verhindern, wird ihr Gebrauch während des letzten Quartals der Schwangerschaft an Bauch und Brüsten empfohlen. Trägt dazu bei, die Pigmentierung zu verteilen, so dass die Flecken abgeschwächt oder beseitigt werden, etwa bei Akne, Sonnenflecken usw. Kräftigend, mit heilender und verjüngender Wirkung, verhindert die Oxidation der Zellen.

30 ml

REF.06053

Ottimo rigeneratore della pelle. Agisce in superficie come fattore idratante naturale, migliorando l'idratazione. Nutre e rigenera, attenuando visibilmente cicatrici e rughe. Corregge e previene i problemi cutanei dovuti al fotoinvecchiamento, attraverso l'autogenerazione della melanina. Per evitare le smagliature durante la gravidanza, si consiglia di utilizzarlo durante l'ultimo trimestre di gravidanza su addome e seno. Contribuisce a ridistribuire la pigmentazione consentendo di ridurre o eliminare macchie dovute a casi di acne, macchie solari, ecc. Azione tonificante, cicatrizzante, ringiovanente e previene l'ossidazione cellulare.

15 ml

REF.06043

Ätherisches Öl Eukalyptus · Olio essenziale di eucalipto



Schlank machender Effekt, fördert die Flüssigkeitsretention, adstringierend, wirkt antibakteriell bei Hautproblemen, Pedikulose und Schuppen, erfrischende Wirkung, strafft die peripheren Blutgefäße. (Ideal zum Massieren von müden Beinen). Wenn Sie einige Tropfen dieses Öls Ihrem täglichen Shampoo hinzufügen, ist dies eine großartige Möglichkeit zur Stimulation der Follikel von Haar und Kopfhaut sowie zur Bekämpfung von Schuppen. Einige Tropfen dieses Öls können auch bei jeder anderen Gesichts- oder Körperbehandlung angewandt werden.

30 ml

REF.06048

Effetto snellente, astringente, agisce come antibatterico per problemi cutanei, pediculosi e forfora, effetto rinfrescante, restringe i vasi sanguigni periferici. (Ideale per massaggi per gambe stanche). Aggiungere qualche goccia di questo olio al tuo shampoo quotidiano è un'ottima opzione per stimolare i follicoli dei capelli e del cuoio capelluto e per combattere la forfora. Puoi anche applicare alcune gocce di questo olio in qualsiasi trattamento per viso o corpo.



u.m.vta: 1  6 

15 ml

REF.06041

Ätherisches Öl Teebaum · Olio essenziale di albero del tè

Seine Anwendungen basieren im Wesentlichen auf seinen antibakteriellen und antiseptischen Eigenschaften, zu denen ein leichter lokaler anästhetischer Effekt kommt. Seine Eigenschaften: heilende Wirkung, schützt die Haut, wirkt direkt beim Schweißabbau, reinigt die Haut, hilft gegen Ekzeme, Wunden, Flecken an Gesicht, Händen und Dekolleté. Entwässernd und schlank machend. Wird auch für Cuticula verwendet, die durch seine antiseptische Wirkung gereinigt wird.

Le sue applicazioni sono fondamentalmente basate sulle sue proprietà battericide e antisettiche, alle quali si aggiunge un lieve effetto anestetico locale. Le sue proprietà: cicatrizzanti, dermoprotettive, agisce direttamente sulla degradazione del sudore, dermopurificante, combatte eczemi, piaghe, macchie su viso, mani e scollatura. Drenante e snellente. Per la sua azione antisettica viene utilizzato anche per le cuticole dopo che sono state rimosse.

30 ml

REF.06046



15 ml

REF.06042

Ätherisches Öl Rosmarin · Olio essenziale di rosmarino

Haar: empfiehlt sich zur Stärkung des Haars. Stimuliert den Kreislauf, fördert das Wachstum und stärkt die Haarwurzeln. Verbessert die Kapillarstruktur von dünnem und brüchigem Haar.

Haut: Rosmarin wird häufig in kosmetischen Anti-Aging-Cremes verwendet und ist ein hervorragendes Antioxidans. Einige seiner Komponenten, wie die Rosmarinsäure, fördern die Bildung von neuen Zellen. Es wirkt abschwellend, entzündungshemmend, heilend, erfrischend und adstringierend.

Capelli: consigliato per rinforzare i capelli. Stimola la circolazione favorendo la crescita, rafforzando le radici e migliorando la struttura capillare dei capelli fini e fragili.

Pelle: il rosmarino trova ampio impiego nelle creme cosmetiche anti-età poiché è un ottimo antiossidante. Alcuni dei suoi componenti, come l'acido rosmarinico, favoriscono la formazione di nuove cellule. È decongestionante, antinfiammatorio, cicatrizzante, rinfrescante e astringente.

30 ml

REF.06047



15 ml

REF.06045

Ätherisches Öl Minze · Olio essenziale di menta

Auf der Haut ist es sehr nützlich, da es bei der Feuchtigkeitretention hilft und so frühzeitiges Altern verhindert. Bei Massagen erzeugt es einigen Stellen eine einmalige entspannende Wirkung. Angewandt in einer täglichen Basiscreme, wirkt es gegen Rötung der Haut aufgrund von Entzündungen oder Akne. Ätherisches Öl aus Minze hat folgende Eigenschaften: reguliert das Hautfett, reinigt bei Akne, beseitigt Ödeme und hilft bei der Flüssigkeitsretention, reduziert Cellulite, wirkt abschwellend und erfrischend für die Haut.

È molto utile sulla pelle in quanto aiuta a trattenere l'umidità, prevenendo l'invecchiamento precoce. Se utilizzato per i massaggi, in zone specifiche, è possibile ottenere un effetto rilassante unico. Applicato insieme a una crema base per uso quotidiano, agisce sugli arrossamenti cutanei dovuti a infiammazioni o acne. L'utilizzo dell'olio essenziale di menta piperita ha proprietà di: regolazione del grasso della pelle, pulizia dell'acne, eliminazione di edemi e ritenzione di liquidi, riduzione della cellulite, azione decongestionante e rinfrescante della pelle.

30 ml

REF.06050



Gesichtsmaske · Maschera viso**Normale und gemischte Haut**
Pelli normali e misteu.m.vta: 1  12

400 ml

REF.04454

**Bereich T: Stirn, Nase und Kinn**

Es handelt sich um eine Kombination für trockene und fettige Haut. Einige Bereiche weisen normalerweise einen Überschuss an Talg auf, wie der Bereich T (Stirn, Nase und Kinn) und andere Stellen leiden mehr unter Dehydrierung, wie etwa im Bereich U (Bereich unterhalb der Wangenknochen und Kiefern).

Seine Wirkstoffe pflanzlichen Ursprungs, Rheum Rhaponticum Root Extract, wirken durch Aktivierung der natürlichen Hydratationsmechanismen der Haut, womit die Hornschicht und dessen Komponenten restrukturiert, das Abblättern reguliert und die Barrierefunktion restauriert werden.

Zona T: fronte, naso e mento

È una combinazione di pelle secca e pelle grassa. Alcune zone tendono ad avere più sebo in eccesso, come la zona T (fronte, naso e mento), e altre zone soffrono maggiormente la disidratazione, come di solito accade alla zona U (zona sotto gli zigomi e la mascella).

I suoi principi attivi di origine vegetale, estratto di radice di rheum rhaponticum, agiscono attivando i naturali meccanismi di idratazione della pelle, ottenendo: ricostruzione dello strato corneo e dei suoi componenti, regolazione della desquamazione, ripristino della funzione di barriera.

Trockene Haut
Pelli seccheu.m.vta: 1  12

400 ml

REF.04974

**Hervorragende Hydratation**

Trockene Haut benötigt immer eine ausgiebige Hydratation und eine besondere Pflege, da sie leichter rot wird und empfindlicher ist. Daher ist die Gesichtsmaske für empfindliche Haut dank ihrer Wirkstoffe pflanzlichen Ursprungs, Salix alba (Silberweide) Bark-Extrakt, alternifolia melaleuca, Curculigo Orchioides Root Extrakt, wirken auf den inneren Kontrollmechanismus des pH-Werts der Haut, repariert die Barrierefunktion und verursacht eine Verringerung der Reaktivität und Empfindlichkeit der Haut. Somit wird die Kohäsion zwischen den Zellen verbessert und die Integrität der Epidermis wiederhergestellt.

Ottima idratazione

Le pelli secche hanno sempre bisogno di un apporto significativo di idratazione e cure speciali in più, poiché tendono ad arrossarsi facilmente e sono più sensibili. Per questo, la maschera viso per pelli sensibili, grazie ai suoi principi attivi di origine vegetale, estratto di corteccia di salix alba (salice), alternifolia melaleuca, estratto di radice di curculigo orchioides, agisce sul meccanismo interno di controllo del pH cutaneo, riparando la funzione di barriera e provocando una diminuzione della reattività e della sensibilità della pelle. Pertanto, migliora la coesione tra le cellule, ripristinando così l'integrità dell'epidermide.

Fettige Haut
Pelli grasseu.m.vta: 1  12

400 ml

REF.03810

**Gleicht den Fettüberschuss aus**

Bewahrt den Feuchtigkeit ausgleich und verhindert, dass eine äußere Substanz wie z.B. Schweiß oder Feuchtigkeit Bakterien produziert. Eine ihrer Komponenten ermöglicht die Feuchtigkeitsabsorption. Dies hinterlässt auf der Haut einen Schutzfilm, der eine Hautsenkung und gleichzeitig die Reinigung und die Hydratation bewirkt. Der Leaf Extrakt aus der Pflanze Barosma Betulina gleicht den Fettüberschuss aus und behandelt die sichtbaren Poren durch Verringerung ihrer Anzahl und Größe, womit die Talgablagerungen ausgeglichen und die Textur der Haut sichtbar verbessert wird.

Bilancia il grasso in eccesso

Mantiene un equilibrio idrico e impedisce a qualsiasi agente esterno come sudore, umidità, ecc., di produrre batteri. Uno dei suoi componenti è responsabile di esercitare un'azione assorbente contro l'umidità. Ciò permette di lasciare sulla pelle un film protettivo che rilascia la pelle, esercitando la sua funzione purificante e idratante. Il suo estratto attivo di foglie di barosma betulina riequilibra il sebo in eccesso e tratta i pori visibili, riducendoli in numero e dimensioni, riequilibrando la secrezione sebacea e migliorando visibilmente la consistenza della pelle.

Gesichtssauna Sauna facciale

u.m.vta: 1  4

105 W

REF. 03280

- Indiziert für die Reinigung der Haut und zur Linderung von Atemwegserkrankungen
- Zubehör: Messbecher und Zubehörteil für die Nase. Diffusor, damit das Spray konstant bleibt. PTC-Erwärmung von hoher Qualität
- Leicht zu reinigen
- Leistung: 105 W

- *Indicato per la pulizia della pelle e per il sollievo delle malattie respiratorie*
- *Accessori: misurino e accessorio per il naso. Nebulizzatore per nebulizzazione sia costante. Riscaldamento PTC di alta qualità*
- *Facile da pulire*
- *Potenza: 105 W*

MEDISANA®



Gesichts-Inhalator Vaporizzatore facciale

u.m.vta: 1  1

1 L

REF. 04952



Nur mit destilliertem Wasser verwenden. Mit Funktion für kalten und warmen Dampf. Der Inhalator umfasst die Funktion OZON-Dampf, was sowohl kalt als auch warm mehr Wasserdampf erzeugt. Wenn das Wasser unter dem Minimum liegt, schaltet sich der Inhalator zur Sicherheit automatisch ab. Das Kopfteil kann um 120° gedreht werden.

- Spannung: 220-240 V
- Frequenz: 50-60 Hz
- Leistung: 650 W
- Fassungsvermögen Tank: 1 l

Utilizzare solo con acqua distillata. Con funzione vapore caldo e freddo. Il vaporizzatore ha la funzione vapore di OZONO, che genera più vapore acqueo sia nel vapore caldo che in quello freddo. Quando l'acqua è al di sotto del minimo, il vaporizzatore si spegnerà automaticamente per sicurezza. La testina può ruotare di 120°.

- *Voltaggio: 220-240V*
- *Frequenza: 50-60Hz*
- *Potenza: 650 W.*
- *Capacità del serbatoio: 1L*



Beutel 10 mini-spateln für creme, transparent

Confezione 10 mini spatole per crema trasparenti



u.m.vta: 1  100

REF.07328





Gesichts-Massagebürste

Spazzola per massaggio

u.m.vta: 1  20 

REF.01811

Ideal für die Exfoliation
Ideale per esfoliare

u.m.vta: 1  50 

REF.06660

Mit Kabel-Schutzkappe
Con cappuccio protettivo per
le setole



Bohrkrätzer

Schiaccia brufoli

u.m.vta: 1  50

Großer Schnäpper
Archetto grande

REF.01477

u.m.vta: 1  50

Kleiner Schnäpper
Archetto piccolo

REF.01478

u.m.vta: 1  40

Doppelt verwendbar
Duplice uso

REF.01479



Konjakwurzel-Schwämme Spugne Konjac

u.m.vta: 1  12 

Schwämme mit extra feiner Textur, hergestellt auf der Grundlage von Konjakwurzeln, reich an Mineralien. Er ist 100% natürlich, biologisch abbaubar, nachhaltig und umweltfreundlich. Frei von Farbstoffen, Konservierungsmitteln und künstlichen Pigmenten. Antimikrobiell dank seiner alkalischen Beschaffenheit und mit hoher Hautreinigungsfähigkeit. Mit dem Schwamm ist es nicht notwendig, Seife oder Reinigungsmittel verwenden, da der Schwamm selbst die Fähigkeit besitzt, den gesamten Schmutz und die Unreinheiten der Haut zu entfernen.

Spugne dalla texture extra fine a base di radici di konjac, ricche di minerali. 100% naturali, biodegradabili, sostenibili e rispettose dell'ambiente. Senza coloranti, conservanti e pigmenti artificiali. Antimicrobico grazie alla sua natura alcalina e con grande capacità di pulire la pelle. Con l'utilizzo della spugna, non è necessario utilizzare sapone o detergenti, poiché la sola spugna ha la capacità di rimuovere tutto lo sporco e le impurità dalla pelle.

REF.04970



Holzkohle aus natürlichem Bambus

- Beseitigt den Überschuss an Talg, sanfte Exfoliation, reinigt die Poren in der Tiefe, welche Bakterien ansammeln können, die zu Akne führen
- Beseitigt die schwarzen Punkte und hinterlässt einen Film zur Versorgung und Verbesserung der Schutzbarriere der Haut, ohne Notwendigkeit der Verwendung von chemischen Scheuermitteln
- Bringt den pH-Wert der Haut ins Gleichgewicht
- Besonders indiziert für fettige Haut und mit Tendenz zu Akne
- Nicht geeignet für empfindliche Haut
- Der Schwamm muss alle 2 Monate ausgetauscht werden

Carbone di bambù naturale

- Rimuove il sebo in eccesso, esfolia delicatamente, purifica in profondità i pori che possono portare a batteri che causano l'acne
- Elimina i punti neri lasciando un film per nutrire e migliorare la barriera protettiva della pelle, senza bisogno di abrasivi chimici
- Riequilibra il pH della pelle
- Particolarmente indicata per pelli grasse e a tendenza acneica
- Non adatta per pelli sensibili.
- La spugna deve essere sostituita ogni 2 mesi

REF.04971



Aloe vera. Beruhigend, feuchtigkeitsspendend und befeuchtend

- Bringt den pH-Wert Ihrer Haut ins Gleichgewicht
- Hinterlässt einen Film zur Versorgung und Verbesserung der Schutzbarriere der Haut
- Sie können sie nach der Haarentfernung verwenden, denn sie hilft dabei, die Haut zu beruhigen und zu befeuchten
- Ideal für normale und gemischte Haut
- Der Schwamm muss alle 2 Monate ausgetauscht werden

Aloe Vera. Calmante, idratante e umettante

- Riequilibra il pH della pelle
- Lascia un film per nutrire e migliorare la barriera protettiva della pelle
- Puoi usarlo dopo la ceretta perché aiuta a lenire e idratare la pelle
- Ideale per pelli normali e miste
- La spugna deve essere sostituita ogni 2 mesi

REF.04972



Samen der Damaszener-Rose. Hydratisiert, nährt und regeneriert

- Hinterlässt einen Film, der befeuchtet, nährt und die Schutzbarriere der Haut verbessert
- Reduziert die Notwendigkeit der Verwendung von Seifen, die Ihre delicate Haut reizen können
- Besitzt einen natürlichen beruhigenden Effekt
- Besonders indiziert für sehr empfindliche Haut, selbst in frühem Alter
- Der Schwamm muss alle 2 Monate ausgetauscht werden

Semi di rosa bulgara. Idrata, nutre e rigenera

- Lascia un film ideale per umettare, nutrire e migliorare la barriera protettiva della pelle
- Riduce la necessità di saponi che possono irritare le pelli delicate
- Ha un effetto calmante naturale
- Particolarmente adatta per pelli molto sensibili e anche in tenera età
- La spugna deve essere sostituita ogni 2 mesi

02

Linie Körperpflege Linea per la cura del corpo

Cremes, Behandlungen und Zubehör...

Crema, trattamenti e accessori...



Basisöle · Oli base



Basisöle sind auch bekannt als Trägeröle. Sie wirken als Träger bei der Anwendung der ätherischen Öle im Gesicht und am Körper und sorgen die notwendige Beweglichkeit bei der Massage durch die Schmierung, die sie bieten. Zugleich bieten sie die für die Mischung eigenen therapeutischen Eigenschaften. Es sind feste Öle, d.h. sie verdampfen nicht (im Unterschied zu den ätherischen Ölen).

Angereichert mit Traubenkernöl. Hochgradig erweichend, schützende Eigenschaften, ideal als Vehikel zur Durchdringung für andere Komponenten, wenn es mit verschiedenen Wirkstoffen kombiniert wird. Wegen seines hohen Gehalts an Antioxidantien, Vitaminen C, D, E und Beta-Carotin, erhöht es die Widerstandskraft der Haut und macht sie elastischer. Wird sehr schnell absorbiert und kann für jeden Hauttyp verwendet werden.

Gli oli base sono anche noti come oli vettori o portanti. Agiscono come vettori portanti nell'applicazione degli oli essenziali su viso e corpo, facilitando il movimento necessario nel massaggio grazie alla lubrificazione che offrono e, a loro volta, conferiscono alla miscela le proprie proprietà terapeutiche. Sono oli fissi, cioè non evaporano (a differenza degli oli essenziali che lo fanno). Arricchiti con olio di vinaccioli. Proprietà altamente emollienti e protettive, ideale come veicolo di penetrazione di altri componenti in combinazione con diversi principi attivi. Per il suo alto contenuto di antiossidanti, vitamine C, D, E e betacarotene, aumenta la resistenza della pelle, rendendola più elastica. Si assorbe molto rapidamente e può essere utilizzato su qualsiasi tipo di pelle.



Basisöl Ringelblume Olio base di calendula

u.m.vta: 1  4 

1 L

REF.06036

Besitzt entzündungshemmende und beruhigende Eigenschaften; vor allem nach aggressiven Behandlungen für die Haut wie die Haarentfernung oder ein Peeling erzeugt das Öl ein Gefühl der Entspannung und lindert Rötungen. Hohe feuchtigkeitsspendende Wirkung, nahrhaft und reinigend. Besonders nützlich für empfindliche Haut wie die von Babys oder Menschen mit ständigen Reizungen. Geeignet für trockene oder sehr trockene Haut. Reich an Vitamin E. Kann direkt als Reinigungsmilch verwendet werden, vor allem bei sehr empfindlicher Haut, die leicht gereizt wird



Ha proprietà antinfiammatorie e lenitive, quindi dopo aver sottoposto la pelle a trattamenti aggressivi come la ceretta o l'epilazione, l'uso dell'olio produce una sensazione di rilassamento e sollievo contro gli arrossamenti. Alto potere idratante, nutriente e struccante. Particolarmente utile per la pelle sensibile come quella dei bambini o delle persone che soffrono di irritazioni costanti. Adatto per pelli secche o molto secche. Ricco di vitamina E. Può essere utilizzato direttamente come struccante, soprattutto su pelli molto sensibili e facilmente irritabili.



Mehr
Informationen
Maggiori
informazioni

SCAN
ME!





Basisöle · Oli base**Basisöl Süße Mandeln**
Olio base di mandorle dolciu.m.vta: 1  4 

1 L

REF.06037

Das Öl aus süßen Mandeln ist eines der Öle par excellence für die Massage. Eigenschaften: gibt der Haut Elastizität und Glätte. Gute Durchdringung der Haut, hinterlässt kein Fett auf der Haut. Nahrhaft und regenerierend. Geeignet für jeden Hauttyp, auch von Kindern und von älteren Menschen. Ideal für brüchige oder rissige Haut. Stärkend für die schwachen Haare, trägt zum Entfernen von Schuppen auf der Kopfhaut bei. Es ist ein natürlicher Feuchtigkeitsspender und regeneriert die Wimpern.

L'olio di mandorle dolci è uno degli oli da massaggio per eccellenza. Proprietà: dona elasticità e levigatezza alla pelle. Buona penetrazione cutanea, non lascia la pelle grassa. Nutriente e rigenerante. Adatto a tutti i tipi di pelle compresi bambini e anziani. Ideale per pelli fragili o screpolate. Rinforza i capelli deboli, aiuta la scomparsa delle squame sul cuoio capelluto. È un rigeneratore e idratante naturale per le ciglia.



**Basisöl Weinrose**
Olio essenziale di rosa mosquetau.m.vta: 1  4 

1 L

REF.06035

Die Weinrose ist regeneriert die Haut hervorragend. Wirkt oberflächlich als natürlicher befeuchtender Faktor und verbessert die Hydratation. Nährt und regeneriert, schwächt Narben und Falten sichtbar ab. Korrigiert und verhindert die Probleme der Haut aufgrund von Lichtalterung durch die Selbsterzeugung von Melanin. Trägt zur Neuverteilung der Pigmentierung bei, wodurch die Flecken abgeschwächt oder beseitigt werden. Kräftigende und heilende Wirkung, verjüngend, verhindert die Oxidation der Zellen.

La rosa mosqueta è un ottimo rigeneratore della pelle. Agisce in superficie come fattore idratante naturale, migliorando l'idratazione. Nutre e rigenera, attenuando visibilmente cicatrici e rughe. Corregge e previene i problemi cutanei dovuti al fotoinvecchiamento, attraverso l'autogenerazione della melanina. Aiuta a redistribuire la pigmentazione e a schiarire ed eliminare le macchie. Azione tonificante, cicatrizzante, ringiovanente che previene l'ossidazione cellulare.

**Basisöl Jojoba**
Olio base di jojobau.m.vta: 1  4 

1 L

REF.06038



Hervorragende Hautpenetration, hinterlässt aufgrund seiner guten Absorptionsfähigkeit kein Fett auf der Haut. Für fettige Haut sowie für die Anti-Akne-Behandlung empfohlen, wegen seiner antibakteriellen Eigenschaften, und zur Anti-Talg-Behandlung, da es den Talg auflöst, der sich in den aktiven Hautfollikeln absetzt und das Kapillarwachstum behindert. Hervorragendes Kapillaröl, das trockene und brüchige Haare nährt. Wirkt als Schutz gegen mögliche Reizungen oder Störungen der Haut durch Färbungen und Dauerwellen.

Ottima penetrazione cutanea, non lascia la pelle grassa grazie alla sua ottima capacità di assorbimento. Indicato per pelli grasse oltre che per trattamenti anti-acne per le sue proprietà battericide e come trattamento antiseborroico poiché scioglie il sebo che si deposita nei follicoli piliferi attivi, ostacolando la crescita dei capillari. Ottimo olio per capelli in quanto nutre i capelli secchi e fragili. Agisce come protettore contro possibili irritazioni o alterazioni della pelle causate da coloranti e permanenti.



**Mehr
Informationen
Maggiori
informazioni**

**SCAN
ME!**

Basisöle · Oli base**Basisöl Teebaum****Olio base di albero del tè**u.m.vta: 1  4 

1 L

REF.06051

Seine Anwendungen basieren im Wesentlichen auf seinen antibakteriellen und antiseptischen Eigenschaften, zu denen noch ein leichter lokaler anästhetischer Effekt kommt. Seine Eigenschaften: heilend, hautschützend, wirkt direkt beim Abbau von Schweiß, hautreinigend, hilft gegen Ekzeme, Wunden, Flecken an Gesicht, Händen, Dekolleté. Entwässernd und schlank machend. Wird auch für die Cuticula verwendet, die durch seine antiseptische Wirkung gereinigt wird.

Le sue applicazioni sono fondamentalmente basate sulle sue proprietà battericide e antisettiche, alle quali si aggiunge un lieve effetto anestetico locale. Le sue proprietà: cicatrizzanti, dermoprotettive, agisce direttamente sulla degradazione del sudore, dermopurificante, combatte eczemi, piaghe, macchie su viso, mani e scollatura. Drenante e snellente. Per la sua azione antisettica viene utilizzato anche per le cuticole dopo che sono state rimosse.



**Basisöl Olive****Olio base di oliva**u.m.vta: 1  4 

1 L

REF.06039

Erweichend, Antioxidantien, belebende, feuchtigkeitsspendend und mit beruhigenden Eigenschaften. Hat eine Fettzusammensetzung, die dem der menschlichen Haut sehr ähnlich ist. Restauriert die Feuchtigkeit und die Barrierefunktion der Haut und begünstigt die Zellregeneration. Seine Anwendung auf der Haut wirkt erweichend, es repariert und schützt vor vorzeitigem Altern. Antimikrobielle und antibakterielle Wirkung.

Proprietà emollienti, antiossidanti, tonificanti, idratanti e calmanti. Ha un profilo lipidico molto simile a quello della pelle umana. Ripristina l'idratazione e la funzione barriera della pelle, favorendo la rigenerazione cellulare. La sua applicazione sulla pelle agisce come emolliente, riparatore e protegge dall'invecchiamento precoce. Attività antimicrobica e antibatterica.

**Basisöl Argan****Olio base di Argan**u.m.vta: 1  4 

1 L

REF.06040

Enthält Antioxidantien wie Vitamin E und ist reich an Fettsäuren. Regenerierend und festigende de Geweben, da es die Kollagen- und Elastinfasern stärkt, die Hautbarriere verbessert und die Reduzierung des Feuchtigkeitsverlusts verhindert, entzündungshemmend für den Gebrauch nach Sonneneinstrahlung, nahrhaft und regenerierend. Dank seines Gehalts an Tocopherol besitzt es ein große anti-oxidierende Wirkung, auch in der Tiefe, bei Ernährungsmangel der Haut. Ideal für Haar und Fingernägel, da es ihnen Glanz gibt und sie durch seine hohe Nährwertkapazität stärkt.

Contiene antiossidanti come la vitamina E ed è ricco di acidi grassi. Rigenera e rassoda i tessuti in quanto rinforza le fibre di collagene ed elastina, migliora la barriera cutanea permettendo la riduzione della perdita di idratazione, antinfiammatorio da utilizzare dopo l'esposizione al sole, nutriente e rigenerante. Grazie al suo contenuto di tocoferoli, ha un grande potere antiossidante, agendo in profondità sulla denutrizione della pelle. Ideale per capelli e unghie in quanto dona loro lucentezza e li rinforza grazie alla sua elevata capacità nutritiva.



Körperpeeling

Esfoliante per il corpo

u.m.vta: 1  20

REF.06648

Arganöl und Aprikosenkern

Peeling, angereichert mit Arganöl, das für Hydratation sorgt, und mit Aprikosenkern, das einen Peeling-Effekt erzeugt und abgestorbene Zellen sowie angesammelte Unreinheiten entfernt. Die Verwendung des Körperpeelings hilft, die abgestorbenen Hautzellen zu beseitigen, die sich trotz der Reinigung ansammeln und so die richtige Sauerstoffzufuhr verhindern. Lindert Haut, die glänzender erscheint, und bereitet sie für die spezifischen Behandlungen vor, deren Wirkstoffe nach dem Peeling besser eindringen. Angenehmes Fruchtaroma.

Kann wegen der natürlichen und milden Eigenschaften des Aprikosenkerns als übliches Körperpeeling genutzt werden. Nicht für empfindliche Haut geeignet

Neue verbesserte Formel

Olio di Argan e nocciolo di albicocca

Esfoliante arricchito con olio di argan che fornisce idratazione e nocciolo di albicocca che ha un effetto esfoliante, eliminando le cellule morte e le impurità accumulate. L'utilizzo dello scrub per il corpo aiuta a rimuovere le cellule morte della pelle che si accumulano nonostante la pulizia, impedendone la corretta ossigenazione. Ammorbidisce la pelle, che appare più liscia e luminosa, preparandola a ricevere trattamenti specifici i cui principi attivi penetreranno meglio dopo l'esfoliazione. Piacevole aroma fruttato.

Può essere usato come un normale scrub per il corpo grazie alle proprietà naturali e delicate del nocciolo di albicocca. Non adatto a pelli sensibili

Nuova formula migliorata



Kit Körper- und Gesichtspeeling mit Gummischaum als Geschenk

Kit esfoliante per corpo e viso con spugna in omaggio

u.m.vta: 1  12

REF.04883



Salze vom Toten Meer, Algen und Zitronenextrakt

Sali del Mar Morto, alghe ed estratto di limone



Für Behandlungen zur Reduzierung des Aussehens und der Intensität der Cellulite oder "Orangenhaut" verfügen wir über festigende, belebende und reduzierende Behandlungen. Alle mit natürlichen Produkten wie Salzen vom Toten Meer, Algen oder Zitronenextrakt. Mit Hilfe von kreisenden Massagen in den problematischsten Bereichen tragen wir zur Absorption des Produkts bei.

Per i trattamenti che aiutano a ridurre l'aspetto e l'intensità della cellulite o della pelle a "buccia d'arancia", abbiamo trattamenti rassodanti, tonificanti e riducenti. Tutti con prodotti naturali come sali del mar morto, alghe o estratto di limone. Con l'ausilio di massaggi circolari nelle zone più problematiche aiuteremo l'assorbimento del prodotto.

Antizellulitischer Wärmeeffekt

Crema anticellulite effetto calore

u.m.vta: 1 25

REF.03546

Salze vom Toten Meer, Aloe vera und Arganöl

Die passende Kombination aus so kräftigen Meeresalgen wie u.a. die LAMINARIA und der FUCUS ermöglichen es, zusammen mit dem Ruscus, dem jodierten Extensin oder dem Koffein, Fettansammlungen (Lypolyse) abzubauen und zu mobilisieren. Die Anregung des Kreislaufs und die lokale Erhöhung der Temperatur schaffen die erforderlichen Voraussetzungen für diesen Prozess und machen diese Creme zu einem idealen Produkt für die Behandlung der Cellulite und dem Volumen. Das Argan- und das Aloe-vera-Öl besitzen restrukturierende und regenerierende Eigenschaften. WÄRMEEFFEKT. Besonders in den problematischsten Bereichen (Gesäß, Hüften, Schenkel usw.) einmassieren und einwirken lassen. Beugt auch gegen die sogenannte "Orangenhaut" vor. Aktiviert die Mikrozirkulation. Nicht für empfindliche Haut empfohlen.

Sali del Mar Morto, aloe vera e olio di argan

L'adeguata combinazione di alghe marine potenti come la LAMINARIA e il FUCUS insieme al ruscus, la estensina iodata o la caffeina, tra gli altri, consente di diminuire e sciogliere l'accumulo di grasso (lipolisi). L'attivazione della circolazione e l'innalzamento locale della temperatura creano le condizioni necessarie per lo sviluppo di questi processi, rendendo questa crema un prodotto ideale per il trattamento della cellulite e del volume. L'olio di argan e aloe vera hanno proprietà ristrutturanti e rigeneranti.

EFFETTO CALORE Massaggiare concentrandosi soprattutto sulle zone più problematiche (glutei, fianchi, cosce, ecc.). Previene anche la cosiddetta "pelle a buccia d'arancia". Attiva la microcircolazione. Non consigliata per pelli sensibili.

250 ml



Festigende remodelierende Wirkung

Rassodante e rimodellante

u.m.vta: 1 20

250 ml

REF.03932

Extrakt aus Zitrone, Kollagen und Algen

Festigende remodelierende Creme, die die Haut festigt, die Zellaktivität stimuliert sowie die Elastizität und die Festigkeit verbessert. Hilft bei der Entfernung von Giftstoffen und remodeliert die Figur. An den problematischsten Stellen einmassieren und einwirken lassen.

Estratto di limone, collagene e alghe

Crema rassodante-rimodellante che rassoda la pelle stimolando l'attività cellulare e migliora l'elasticità e la compattezza. Aiuta ad eliminare le tossine e rimodella la figura. Massaggiare concentrandosi sulle zone più problematiche.

u.m.vta: 1 5

500 ml

REF.03931

250 ml



500 ml



Arganöl + Aloe vera Olio di argan + Aloe vera



Arganöl dringt schnell in die Haut ein und hydratisiert sie und ohne Fettüberschuss. Der Baum der Argania Spinosa, der nur im Südwesten Marokkos wächst, ist aufgrund seiner Eigenschaften ein einzigartiger Baum auf der Welt. Das Öl wird ohne Verwendung von chemischen Produkten entnommen, es ist ein biologisches Produkt mit nachgewiesenen Vorteilen. Die durchgeführten chemischen Analysen bestätigen seine wertvollen dermatologischen Eigenschaften, und die Kombination mit der Aloe vera bewirkt, dass die heilende und regenerative Wirkung verstärkt wird.

L'olio di Argan penetra rapidamente nella pelle lasciandola idratata e priva di sebo in eccesso. L'albero di Argania Spinosa, che cresce solo nel sud-ovest del Marocco, è per le sue caratteristiche un albero unico al mondo. L'olio viene estratto senza alcun utilizzo di sostanze chimiche ed è un prodotto biologico dai benefici comprovati. Le analisi chimiche effettuate confermano le sue preziose proprietà dermatologiche e la combinazione con l'aloè vera potenzia gli effetti cicatrizzanti e rigenerativi.

Lotion feuchtigkeitsspendende Body Milk Lozione idratante body milk

u.m.vta: 1  8

REF.04458

Arganöl und Aloe vera

Ihre Zusammensetzung, die reich an Arganöl und Aloe vera ist, sorgt für Sanftheit, Hydratation und ein große Regenerationskraft für die Haut. Stärkt den Hydro-Lipid-Mantel und bereitet die Haut auf den alltäglichen Stress vor, so dass die ständige Verwendung der Lotion hilft, Schläffheit und Anzeichen des Alterns zu regulieren und zu verhindern. Wird schnell absorbiert. Besonders indiziert für trockene Haut.

Olio di argan e aloe vera

La sua composizione ricca di olio di argan e aloe vera dona morbidezza, idratazione e un grande potere rigenerante alla pelle, rinforzando il mantello idrolipidico e preparandola allo stress quotidiano, in modo che il suo uso continuato aiuti a regolare ed evitare la comparsa di flaccidità, e segni di invecchiamento. Rapido assorbimento. Particolarmente adatto per pelli secche.



Vibrierender Massagstab mit roter Lampe MEDISANA Massaggiatore a luce rossa MEDISANA



u.m.vta: 1	 4
------------	---

REF.06590



- Angenehme Massage durch Vibration
- Möglichkeit der Konfiguration verschiedener Massage-Winkel
- Enthält 5 austauschbare Massage-Zubehör
- Die rote Lampe und die Wärme können ebenfalls angeschlossen werden
- 2 verstellbare Niveaus der Massageintensität
- Praktisches Design für eine bequeme Selbstmassage

- *Piacevole massaggio vibratorio*
- *Possibilità di impostare diversi angoli di massaggio*
- *Include 5 accessori per massaggi intercambiabili*
- *È possibile collegare anche luce rossa e calore*
- *2 livelli di intensità di massaggio regolabili*
- *Design pratico per un comodo automassaggio*

Behandlungsflüssigkeit kalte Binden**Liquido per i bendaggi a freddo**u.m.vta: 1  6 **REF.07012**

ENTSPANNEND – ERFRISCHEND – ENTLASTEND – ANTIZELLULITIKUM
Von reduzierender Wirkung. Pflanzliche und hypothermische Wirkstoffe, KONZENTRAT 1 x 3

Mischung: 1 Teil Flüssigkeit kalte Binden + 3 Teile Wasser

Kosmetische Lotion mit pflanzlichen Wirkstoffen (Seetang, Efeu, Stechpalme) und hypothermische Wirkstoffe, die ein lokales Abkühlen der Temperatur in dem behandelten Bereich für einen kontrollierten Zeitraum erzeugen.

GEBRAUCHSANLEITUNG:

Einen Teil der Lotion mit 3 Teilen Wasser mischen und die Binden in der Mischung aufweichen und damit den zu behandelnden Bereich einwickeln. 30 bis 45 Minuten einwirken lassen und etwa 2 Stunden lang nicht duschen. Zwei- oder dreimal in der Woche verwenden.

RILASSANTE - RINFRESCANTE - DECONGESTIONANTE - ANTI-CELLULITE ad azione



riduttrice. Principi attivi vegetali e ipotermici CONCENTRATO 1 x 3

Miscela: 1 parte di liquido per bendaggio freddo + 3 parti di acqua

Lozione cosmetica con principi attivi vegetali (fucus, edera, aquifolium) e ipotermici che producono un raffreddamento locale della temperatura nella zona trattata per un tempo controllato.

COME USARE:

Mescolare una parte della lozione con 3 parti di acqua e immergere le bende nella miscela, avvolgendole poi intorno alla zona da trattare. Tenere da 30 a 45 minuti e non fare la doccia per circa 2 ore. Usare due o tre volte a settimana.

**Rolle kalte Binden 15x10 Krepp****Rotolo per bendaggi freddi 15x10 crepe**u.m.vta: 1  50**REF.07108****Rolle kalte Binden 15x10 Krepp****Rotolo per bendaggi freddi 10x10 crepe**u.m.vta: 1  65**REF.03041**

Hergestellt aus dickem und elastischem Kreppstoff für Behandlungen mit kalten Binden und Kompressionsbehandlungen. Tränken Sie die Binden in die Flüssigkeit für kalte Binden (07012), um u.a. eine antizellulitische, entzündungshemmende Behandlung zu erzielen

Realizzato in tessuto crepe spesso ed elastico per trattamenti di bendaggio a freddo e trattamenti di compressione. Immergere le bende nel liquido per bendaggi freddi (07012) per effettuare un trattamento anticellulite, antinfiammatorio, ecc.

Elastische Binde, sowohl längs als auch quer einsetzbar. Zusammensetzung: Baumwolle: 93,84%, beschichtetes Elastomer: 6,2%. Höhere Qualität. Binde mit Kette, an den Seiten geflochten, ideal für Körperbehandlungen

Bendaggio elastico sia longitudinale che trasversale. Composizione: cotone: 93,84%, elastomero rivestito: 6,2%. Qualità superiore. Benda a bordo intrecciato sui lati, ideale per trattamenti corporali

Fausthandschuh aus Baumwolle

Guanto in cotone



u.m.vta: 12  96

REF.01916



Fausthandschuh mit Naturborsten

Guanto in crine di cavallo



u.m.vta: 1  20 

REF. 01084



FarGrandeer Schwamm aus Gummi für Bad/Massage

Spugna colorata in gomma per bagno/massaggio

u.m.vta: 1  16 

REF. 04591

- Doppelte Art von Zinken.
- Ideal für Durchblutung, Cellulite, empfindliche Haut.
- Langanhaltend, sammelt keine Haare an und benötigt wenig Seife.
- Doppio tipo di denti.
- Ideale per circolazione, cellulite, pelli sensibili.
- A lunga tenuta, non accumula capelli e necessita di poco sapone.

u.m.vta: 1  24 

REF. 04590



Groß · Grande





Klein · Piccolo



Für das Bad

Spazzola da bagno

u.m.vta: 1  12 

REF. 00526

- Naturfaser. Griff aus Holz
- Fibra naturale. Manico in legno

u.m.vta: 1  15 

REF. 00679

- Nylon-Borsten
- Setole in nylon

Holz · Legno



Couleurs · Colorata





03



Haarentfernung Depilazione

Wachs kg, Wachs Roll-on, Wachsschmelzer,
Zubehör, Enthaarungspinzetten...

Cera a kg, cera roll-on, scaldacera, acces-
sori, pinzette...

Wachspferlen, 1 Kg-Tüte

Confezione da 1 Kg di cera in perle

u.m.vta: 1		6	
------------	---	---	---

Honig-Wachspferlen
Perle Cera Miele

REF.07465

Wachspferlen rosa für empfindliche Haut
Perle Cera Rosa - Pelli Sensibili

REF.07466

Wachspferlen grün mit Aloe Vera
Perle Cera Verdi - Aloe Vera

REF.07467

Wachspferlen azulen
Perle Cera Azulene

REF.07468



Schmelzen Sie das Wachs in einem Wachserhitzer. Verrühren Sie es so lange, bis es eine weiche und gleichförmige Konsistenz annimmt.

Stellen Sie vor dem Auftragen sicher, dass das Wachs die optimale Temperatur erreicht hat. Tragen Sie mit Hilfe eines Holz- oder Metallspatels eine Wachsschicht in Haarwuchsrichtung auf. Lassen Sie diese nicht vollständig erkalten und ziehen Sie sie entgegen der Haarwuchsrichtung mit einem Zug ab, um die Haare mit der Wurzel zu entfernen.

- Wirksam bei kurzen Haaren
- Mit natürlichen Inhaltsstoffen
- Perfekte und langanhaltende Enthaarung
- Ohne Wachsstreifen



Sciogliere la cera in un fonditore. Mescolare bene fino ad ottenere una cera liscia ed omogenea.

Prima dell'applicazione verificare che la temperatura della cera sia ottimale. Applicare uno strato di cera con una spatola di legno o metallo nella stessa direzione della crescita dei peli. Non lasciare raffreddare completamente e rimuovere contropelo con uno strappo per estrarre i peli dalle radici.

- Efficace su peli corti
- Con ingredienti naturali
- Depilazione perfetta e duratura
- Non usare strisce

Beutel 1 kg Wachsscheiben

Confezione di dischi di cera da 1 Kg

u.m.vta: 1  6 

REF.04675

- Wachsscheiben **Brasilian**
- Bidirektional
- Extra flexibel
- Keine Papierstreifen erforderlich

- Dischi di cera **Brasilian**
- Bidirezionale
- Extra flessibile
- Non ha bisogno di strisce di carta

REF. 03916

Honig
Miele



REF. 03917

Empfindliche
Haut mit
Titandioxid
*Per pelli sensibili
con biossido di
titanio*



REF. 03918

Aloe Vera
Aloe Vera



REF. 03919

Arganöl
Olio di Argan



REF. 03920

Kakao
Cacao



REF. 04260

Azulen
Azulene



Die Haarentfernung mit niedrig schmelzendem Wachs ist sehr effektiv beim Körperhaar. Seine spezielle Formel auf der Grundlage von natürlichem Bienenwachs und Kolophonien von höchster Qualität bereitet die Haut vor? Und macht die Poren weicher. Seine Anhaftung ist vollständig, so dass es das Körperhaar von der Wurzel her entfernt, was das Neuwachstum verzögert. Um eine elastische und cremige Konsistenz bei Raumtemperatur zu erhalten, werden einige unserer Wachse mit Titandioxid verarbeitet. Auf diese Weise erreichen wir einen niedrigeren Schmelzpunkt, was die Haarentfernung begünstigt. Kombinierbare skalierte Preise ab 6 Stück mit allen Referenzen auf Seite 612 außer Referenz 04675.

La ceretta a basso punto di fusione è molto efficace nella rimozione dei peli. La speciale formula a base di cera d'api naturale e colofonia di alta qualità, prepara la pelle ammorbidendone i pori. La sua aderenza è totale quindi estrae i peli alla radice, ritardandone la ricomparsa. Per ottenere una consistenza cremosa ed elastica a temperatura ambiente, alcune delle nostre cere sono realizzate con biossido di titanio. In questo modo, otteniamo un punto di fusione più basso che favorisce la depilazione. Prezzi scalabili cumulabili a partire dal box di 6 unità con tutte le referenze a pagina 612 tranne il riferimento 04675.

Beutel 1 kg Wachs made in Spain

Confezione da 1 kg di cera prodotta in Spagna

Bereiche der Behandlung: Achseln, Brust, Rücken, Arme, Bauch, Beine, Gesicht und Leisten (Roll-on für das Gesicht). Wählen Sie dasjenige aus, das am besten für Ihren Typ von Körperhaar und Haut passt: transparent, ultra-cremig, farGrande, parfümiert, niedrige Schmelze, usw. Skalierter Preis, kombinierbar mit einer der Referenzen auf Seite 613-614



Area di trattamento: inguine, ascelle, braccia, labbro superiore, viso, corpo. Scegli quella che meglio si adatta in funzione dell'elasticità, del tipo di pelo e di pelle: trasparenti, elastiche, colorate, profumate, a basso punto di fusione, ecc. Prezzo scalato cumulabile con qualsiasi riferimento a pagina 613-614.

Wachspastillen rosa – doppelt höhere Elastizität

Compresse di cera rosa - doppia elasticità superiore

u.m.vta: 1 12

1 kg

REF.06323

Flexibel, ermöglichen sie das Auftragen einer feinen Schicht, die das Wärmegefühl reduziert. Das klassische Wachs, speziell für die Enthaarung von Leisten und Achseln.

Flessibili, consentono di applicare uno strato sottile riducendo la sensazione di calore. Cera classica, soprattutto per la ceretta all'inguine e alle ascelle.



Wachspastillen grün - Elastizität

Compresse di cera verde - elasticità normale

u.m.vta: 1 12

REF.06324

Transparent oder semitransparent, mit flüssiger Textur, kräftige Wirkung und rasches Trocknen. Leicht und kristallin, geeignet für jeden Bereich des Körpers.

Trasparente o semitrasparente, di consistenza fluida, tiraggio forte e asciugatura rapida. Leggera e cristallina, adatta a qualsiasi zona del corpo.



Wachspastillen blau - höhere Elastizität

Compresse di cera blu - elasticità superiore

u.m.vta: 1 12

REF.06325

Transparent oder semitransparent, mit flüssiger Textur, kräftige Wirkung und rasches Trocknen. Leicht und kristallin, geeignet für jeden Bereich des Körpers.

Trasparente o semitrasparente, di consistenza fluida, tiraggio forte e asciugatura rapida. Leggera e cristallina, adatta a qualsiasi zona del corpo.



Beutel 1 kg Wachs made in Spain
Confezione da 1 kg di cera prodotta in Spagna



Bereich der Behandlung: Leisten, Achseln, Arme, Oberlippe, Gesicht, Körper. Wählen Sie dasjenige aus, das am besten für Ihren Typ von Körperhaar und Haut passt: transparent, elastisch, farGrande, parfümiert, niedrige Schmelze, usw.
 Skalierter Preis, kombinierbar mit einer der Referenzen auf Seite 613-614.

Area di trattamento: inguine, ascelle, braccia, labbro superiore, viso, corpo. Scegli quella che meglio si adatta in funzione dell'elasticità, del tipo di pelo e di pelle: trasparenti, elastiche, colorate, profumate, a basso punto di fusione ecc.
 Prezzo scalato cumulabile con qualsiasi riferimento a pagina 613-614.

Wachspastillen Schokolade – dreifach höhere Elastizität
Compresse di cera cioccolato - tripla elasticità superiore

u.m.vta: 1 12

1 kg

REF.06328

Flexibel und elastisch, begünstigen die Anwendung und Entfernung auf sanfte und wenig aggressive Weise für die Haut. Sorgt für eine sanfte Haarentfernung, wobei die Haut leicht parfümiert wird.

Flessibili ed elastiche, favoriscono l'applicazione e la rimozione in modo delicato e non aggressivo per la pelle. Depilazione delicata, lascia la pelle leggermente profumata.



Wachspastillen Wein – dreifach höhere Elastizität
Compresse di cera vino - tripla elasticità superiore

u.m.vta: 1 12

1 kg

REF.06327

Flexibel und elastisch, begünstigen die Anwendung und Entfernung auf sanfte und wenig aggressive Weise für die Haut. Von intensiver Farbe, sorgt es für eine sanfte Haarentfernung, wobei die Haut leicht parfümiert wird.

Flessibili ed elastiche, favoriscono l'applicazione e la rimozione in modo delicato e non aggressivo per la pelle. Di colore intenso, offre una depilazione delicata, lasciando la pelle leggermente profumata.



Box 20 Wachsscheiben Scatola da 20 dischi di cera

u.m.vta: 1



24



REF. 04070

Aloe vera
Aloe vera



REF. 04071

Honig
Miele



REF. 04072



Empfindliche Haut
Pelle sensibile



Die Haarentfernung mit niedrig schmelzendem Wachs ist sehr effektiv beim Körperhaar. Seine spezielle Formel auf der Grundlage von natürlichem Bienenwachs und Kolophonien von höchster Qualität bereitet die Haut vor? Und macht die Poren weicher. Seine Anhaftung ist vollständig, so dass es das Körperhaar von der Wurzel her entfernt, was das Neuwachstum verzögert. Um eine elastische und cremige Konsistenz bei Raumtemperatur zu erhalten, werden einige unserer Wachse mit Titandioxid verarbeitet. Auf diese Weise erreichen wir einen niedrigeren Schmelzpunkt, was die Haarentfernung begünstigt. Gestaffelte Preise, kombinierbar mit Seite 615.

La ceretta a basso punto di fusione è molto efficace nella rimozione dei peli. La speciale formula a base di cera d'api naturale e colofonia di alta qualità, prepara la pelle ammorbidendone i pori. La sua aderenza è totale quindi estrae i peli alla radice, ritardandone la ricomparsa. Per ottenere una consistenza cremosa ed elastica a temperatura ambiente, alcune delle nostre cere sono realizzate con biossido di titanio. In questo modo, otteniamo un punto di fusione più basso che favorisce la depilazione. Prezzo scalato cumulabile con pagina 615.

Wachs-Tablett
Cera in vassoio

u.m.vta: 1  12 

Honig
Miele

500 g

REF. 03722

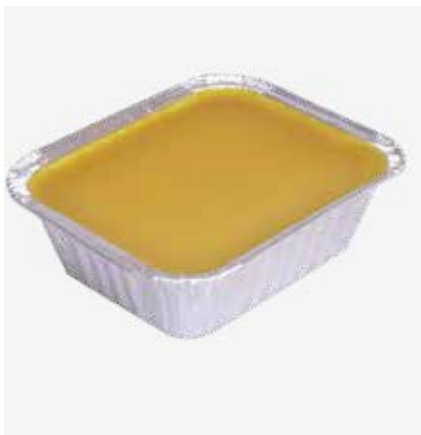

Chlorophyll
Clorofilla

500 g

REF. 03726



Wachsdose
Cera in barattolo

u.m.vta: 1  24

Empfindliche Haut
Pelle sensibile

REF.04563



Honig
Miele

REF.03728



Aloe Vera
Aloe Vera

REF.04735



u.m.vta: 1  12

Empfindliche Haut
Pelle sensibile

REF.04565



Honig
Miele

REF.04564



Aloe Vera
Aloe Vera

REF.04736





400 ml



800 ml



Wachsschmelzer Scaldacera

u.m.vta: 1		12	
------------	---	----	---

REF. 03321



- Leistung: 110 W
- Mit Thermostat
- Ohne Kasserolle
- Geeignet für Dosen von 400 und 500 g
- Potenza: 110W.
- Con termostato
- Senza recipiente
- Adatto per lattine da 400 e 500 g

u.m.vta: 1		60
------------	---	----

REF. RE03321/02

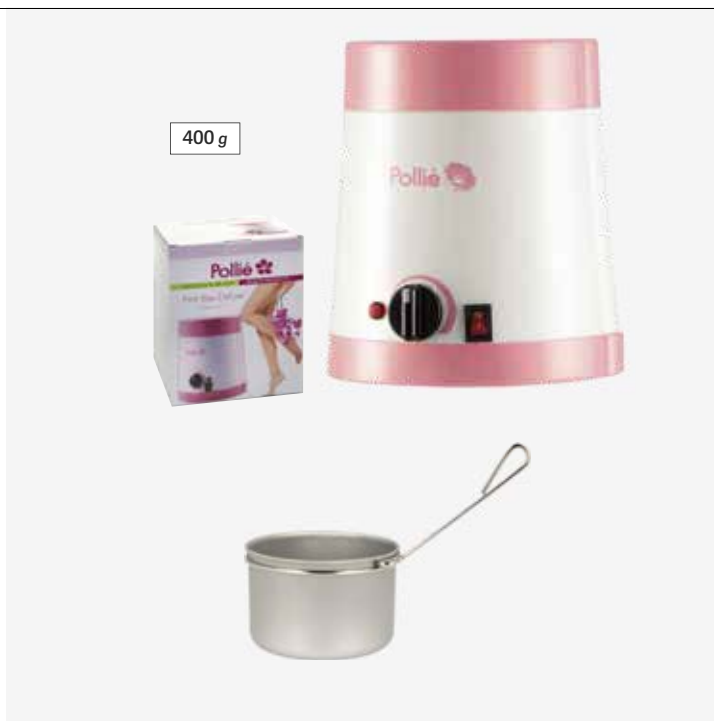
Ersatzteil
Ricambi



u.m.vta: 1		12	
------------	---	----	---

REF. 03322

- Leistung: 175 W
- Mit Thermostat
- Enthält Kasserolle von 800 g
- Rasche Erwärmung des Wachses
- Sicher und ergonomisch
- Leicht und von kleinen Dimensionen
- Für Scheiben, Wachs oder Perlen, Kasserolle verwenden
- Potenza: 175W
- Con termostato
- Include recipiente da 800 g
- Rapido riscaldamento della cera
- Sicuro ed ergonomico
- Leggero e compatto
- Per dischi, cera o perle, usare recipiente



u.m.vta: 1		60
------------	---	----

REF. RE03322/01

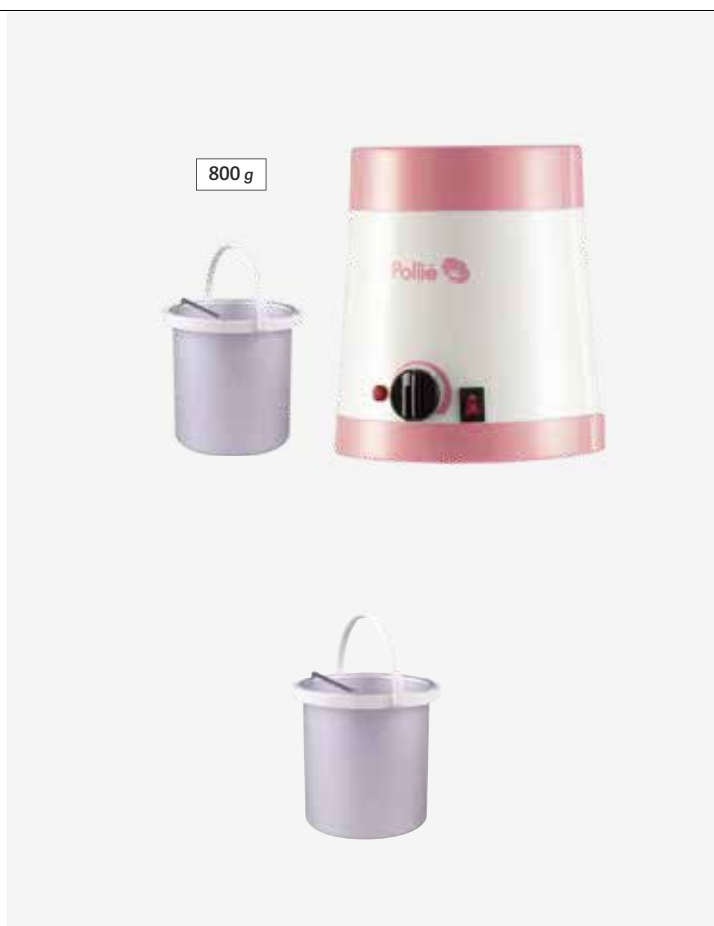
Ersatzteil
Ricambi



Wachsschmelzer Scaldacera

u.m.vta: 1	 12	
------------	--	---

REF. 03154

- Leistung: 80 W
- Mit Thermostat
- Mit Kasserolle von 450 g inbegriffen

- Potenza: 80W.
- Con termostato
- Con recipiente da 450 g incluso



Schutzfolien Wachsschmelzer Protezione per scaldacera

u.m.vta: 1	 16
------------	--



REF. 03716

- Beutel 100 kreisförmige Schutzfolien für Wachsschmelzer
- Innendurchmesser: 9,8cm
- Außendurchmesser: 16cm
- Maximaler Innendurchmesser: 13,5cm

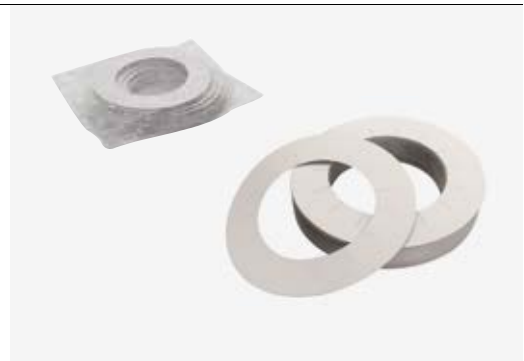
- Confezione da 100 cerchi protettivi per scaldacera
- Diametro interno: 9,8cm
- Diametro esterno: 16cm
- Diametro interno massimo: 13,5cm



Wachsschmelzer Scaldacera

u.m.vta: 1	 12	
------------	--	---

REF. 03612

- Leistung: 90 W
- Elektronischer Temperatur-Thermostat
- Ablage aus Aluminium
- Rasche Erwärmung des Waxes
- Sicher und ergonomisch
- Leicht und von kleinen Dimensionen
- Kasserolle mit ausziehbarem Griff inbegriffen

- Potenza: 90W.
- Termostato elettronico di temperatura
- Serbatoio in alluminio
- Rapido riscaldamento della cera
- Sicuro ed ergonomico
- Leggero e compatto
- Recipiente estraibile incluso con manico

u.m.vta: 1	 1
------------	---



250 g

REF. RE03612/01

**Ersatzteil
Ricambi**



Wachsschmelzer Pollié Scaldacera Pollié

u.m.vta: 1	 12	
------------	--	---



REF. 06614/58



REF. 06614/70



- Leistung: 40 W
- Wachsschmelzer 125 ml. Kompakt, ideal für die Haarentfernung von kleinen Bereichen wie Nase, Ohren, Augenbrauen und Bartkontur

- Potenza: 40W.
- Scaldacera 125 ml. Compatta, ideale per ceretta su piccole zone come naso, orecchie, sopracciglia e contorno barba

125 ml

REF. RE06614/01



Ersatzteil · Ricambi

- Kasserolle Wachs für wachsschmelzer
- Ref.-Nr. 06614/58, 06614/70 und 04505
- Recipiente per cera per scaldacera
- rif. 06614/58, 06614/70 e 04505

Wachsschmelzer mit Thermostat aus Metall Scaldacera con termostato in metallo

Ideal zur Verwendung mit Wachsscheiben oder Pastillen
Ideale per l'uso con dischi o pastiglie in cera

u.m.vta: 1  1

250 g

REF. 02905

- Leistung: 125W
- Mit Filter
- Potenza: 125W.
- Con filtro

400 g

REF. 02928

- Leistung: 125W
- Mit Filter
- Geeignet für Dosen von 400 und 500 g
- Potenza: 125W.
- Con filtro
- Adatto per barattoli da 400 e 500 g

1 kg

REF. 02908

- Leistung: 250 W
- Mit Filter
- Potenza: 250W.
- Con filtro

4 kg

REF. 02900

- Leistung: 450 W
- Mit Filter
- Potenza: 450W.
- Con filtro



GROSSE SCHMELZER FUSORI GRANDI

Wachsschmelzer mit Thermostat aus Metall Scaldacera con termostato in metallo

Ideal zur Verwendung mit Wachsscheiben oder Pastillen
Ideale per l'uso con dischi o pastiglie in cera

u.m.vta: 1  1

10 kg

REF. 07821

- Leistung: 2 x 450 W
- Mit Filter
- Potenza: 2 x 450W
- Con filtro



12 kg

REF. 04216

- Leistung: 2 x 450 W
- Mit Filter
- Potenza: 2 x 450W
- Con filtro

20 kg

REF. 04217

- Leistung: 2 x 450 W
- Mit Filter
- Potenza: 2 x 450W
- Con filtro

Wachsschmelzer mit 2 miteinander verbundenen Behältern und mit Filter zum Filtern von wiederverwendbarem Wachs. Enthält 2 unabhängige Thermostate, einen für jeden Behälter

Scaldacera con 2 contenitori collegati e filtro per filtrare la cera riutilizzabile. Contiene 2 termostati indipendenti per ogni contenitore

Wachsspachtel Holz

Spatola per cera in legno

u.m.vta: 12  12

Mini Klein
Mini Piccola
REF.01627 **REF.01628**

REF.01630 Mittel
Media



REF.01632 Groß
Grande

REF.01634 Super-groß
Extra grande





Box 100 Spachteln aus Holz

Scatola da 100 spatole in legno

u.m.vta: 1  50 **REF.03282****REF.07114**

Beutel 100 Spachteln aus Holz

Sacchetto da 100 spatole in legno

u.m.vta: 1  100 **REF.06651**

Pack 100 Wachsspachteln spezial Confezione da 100 spatole speciali per cera

u.m.vta: 1  50

REF.01636



Wachsspachtel mit Griff Spatola per cera con manico

u.m.vta: 12  12

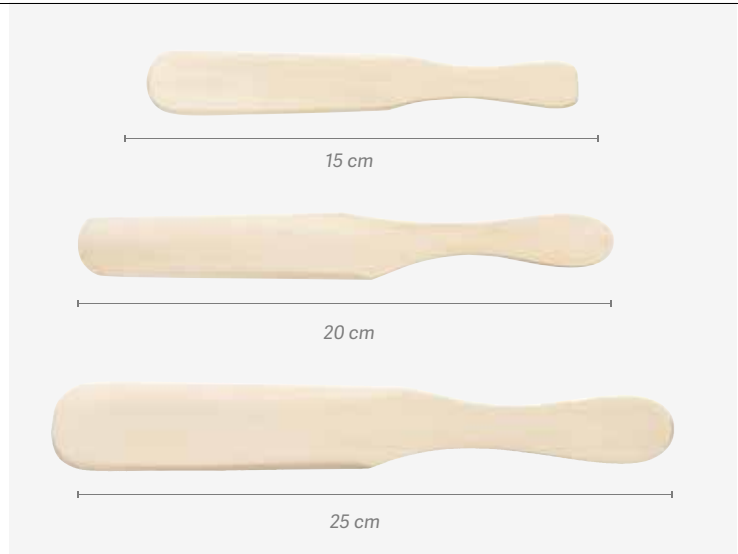

REF.01629



REF.01631

REF.01633

Spachtel Extra Flex aus Kunststoff Spatola Extra Flex in plastica

u.m.vta: 1  24 

REF.03229

Farbe weiß. Material Hartplastik für Wachs oder jede Art von Schönheitsbehandlung, bei der es benötigt wird



Colore bianco. Materiale plastico rigido per cera o qualsiasi tipo di trattamento estetico che lo richieda

REF.03230

Weißer Farbe. flexibles Kunststoffmaterial
Colore bianco. materiale plastico flessibile



Wachsspachtel aus Metall/Holz Spatola per cera in legno/metallo

u.m.vta: 1  12 



REF.03469

REF.01419



Wachs-Roll-on made in Spain

Roll-on con cera prodotta in Spagna

u.m.vta: 20  20 

Bereiche der Behandlung: Achseln, Brust, Rücken, Arme, Bauch, Beine, Gesicht und Leisten (Roll-on für das Gesicht). Wählen Sie dasjenige aus, das am besten für Ihren Typ von Körperhaaren und Haut passt: transparent, ultra-cremig, farGrande, parfümiert usw. Gestaffelte Preise, kombinierbar. Seite 624-625.

Area di trattamento: ascelle, petto, schiena, braccia, addome, gambe, viso e inguine (roll-on facciale). Scegli quello più adatto al tipo di peli e pelle: trasparente, ultra cremoso, colorato, profumato, ecc. Prezzi scalati combinabili pagina 624-625.



Naturwachs- - kristallin

Naturale - cristallina

REF.06317

Transparent oder semitransparent, mit flüssiger Textur und kräftiger Wirkung. Seine hervorragende Kombination aus Pinienharzen machen ihn zum idealen Werkzeug für eine perfekte Haarentfernung.

Trasparente o semitrasparente, dalla consistenza fluida e con tiraggio forte. La sua eccellente combinazione di resine di pino lo rendono ideale per una perfetta depilazione.

Blau - kristallin

B lu - cristallina

REF.06318

Transparent oder semitransparent, mit flüssiger Textur und kräftiger Wirkung. Geeignet für alle Stellen, selbst die empfindlichsten.

Trasparente o semitrasparente, dalla consistenza fluida e con tiraggio forte. Adatto a tutte le zone, anche quelle più sensibili.

Gold - irisierende Pigmente

Oro - pigmenti iridescenti

REF.06321

Dichte Textur, die die Anhaftung begünstigt und das Wärmegefühl und den Schmerz reduziert. Dank der vergoldeten Partikel erhält das Wachs seine Temperatur, was die Anwendung und den Start erleichtert.

Consistenza densa che favorisce l'aderenza e riduce la sensazione di calore e dolore. Grazie alle particelle d'oro, la cera mantiene la sua temperatura, facilitando l'applicazione e il tiraggio.



Rosa - cremig Rosa - cremosa

110 g

REF.06319

Transparent oder semitransparent, mit flüssiger Textur und kräftiger Wirkung. Seine elastische Textur erleichtert die Haarentfernung bei jedem Typ von Körperhaar.

*Cera roll-on rosa - cremosa
Trasparente o semitrasparente, dalla consistenza fluida e con tiraggio forte. La sua consistenza elastica facilita la depilazione per qualsiasi tipo di pelo.*

Schokolade - cremig Cioccolato - cremosa

REF.06320

Von angenehmer cremiger und elastischer Textur für einen perfekten Start. Für eine sanfte und wirkungsvolle Haarentfernung, mit einem intensiven Aroma nach Schokolade.

Gradevole consistenza cremosa ed elastica per un tiraggio perfetto. Per una depilazione delicata ed efficace, con un intenso profumo di cioccolato.

Wein - cremig Vino - cremosa

110 g

REF.06322



Von angenehmer cremiger und elastischer Textur, für einen perfekten Start. Für eine sanfte und wirkungsvolle Haarentfernung, wobei die Haut leicht parfümiert wird.

Gradevole consistenza cremosa ed elastica per un tiraggio perfetto. Per una depilazione delicata ed efficace che lascia la pelle leggermente profumata.

110 g



Wachs-Roll-on Cera Roll-on

u.m.vta: 24  24 

Das System der Haarentfernung Roll-on ist optimal für alle Profis, die nach den besten Ergebnissen streben. Die Harze, mit denen wir die Wachse herstellen, können bei höherer Temperatur als niedrig schmelzendes Wachs verwendet werden, mit dem Vorteil, dass sie durch einen feinen Streifen aufgetragen werden. So kühlt sich das Wachs beinahe augenblicklich ab, und das Wärmegefühl auf der Haut wird minimiert. Das Wachs kann leicht mit den Hygienestreifen entfernt werden. Gestaffelte Preise, kombinierbar, Seite 626-627 außer Referenz 03907.

Il sistema di depilazione roll-on è ottimale per quei professionisti che cercano di ottenere i migliori risultati. Le resine con le quali produciamo le cere possono essere utilizzate ad una temperatura più elevata rispetto alle cere a basso punto di fusione, con il vantaggio di essere applicate mediante una striscia più sottile. Così, la cera si raffredda quasi istantaneamente e la sensazione di calore sulla pelle è ridotta al minimo. La cera si rimuove facilmente con le salviette igieniche. Prezzi scalati combinabili pagina 626-627 tranne il riferimento 03907.

Honigwachs
Miele

REF.03704

Talkum mit Titandioxid
Talco con biossido di titanio

REF.03705

Aus Olivenöl
All'olio d'oliva

REF.03739

Aloe vera
Aloe Vera

REF.03740

Für Männer
Uomo

REF.03858

Azulen
Azulene

REF.04259

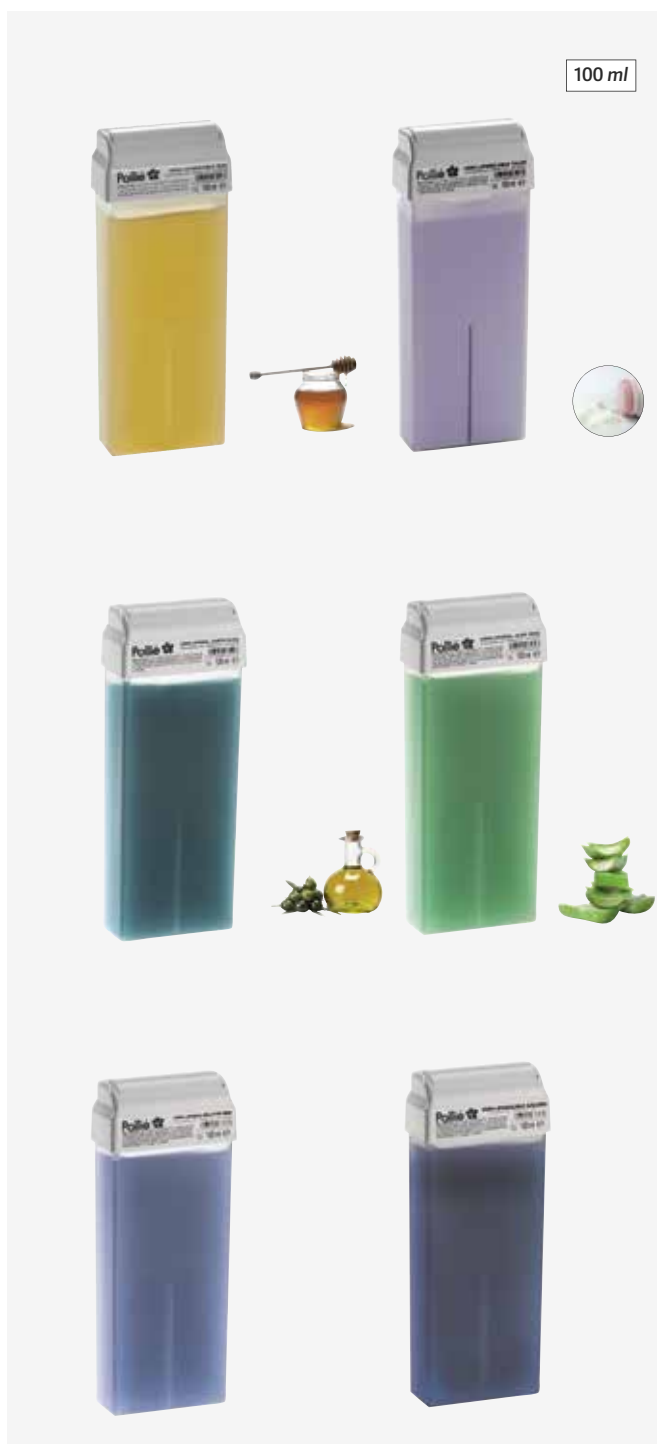

Kokos
Cocco

REF.04678

Apfel
Mela

REF.04674

Banane
Banana

REF.04677

Kakao
Cacao

REF.03748

Argan
Argan

REF.03706

Rosen, empfindliche
Haut, mit Titandioxid
*Rosa pelli sensibili con
biossido di titanio*

REF.03749

Facial
Facciale



24 u

REF.03907



Roll-on-Heizgerät mit Innenthermostat

Riscaldatore roll-on con termostato interno

u.m.vta: 1  30 

REF. 03379

- Leistung: 15W
- Heizgerät für Wachs-Roll-on mit seitlicher Anzeige des Wachsniveaus
- Ergonomisches Design
- Erreicht rasch die optimale Temperatur
- Dank seines Innendesigns passte es sich an jeden Typ von Roll-on an
- Innenthermostat, der die ideale Temperatur für die Anwendung des Waxes erhält
- LED-Betriebsanzeige
- 100-240 V~
- 50/60 Hz

- Potenza: 15W.
- Riscaldatore roll-on con visore laterale per il livello di cera
- Design ergonomico
- Rapido pa raggiungere la temperatura ottimale
- Grazie al suo design interno si adatta a qualsiasi tipo di roll-on
- Termostato interno che mantiene la temperatura ideale per l'applicazione della cera
- Led indicatore di accensione e spegnimento
- 100-240V~
- 50/60Hz



Ladegerät Roll-on-Heizgerät Ref.-Nr. 03379

Base per riscaldatore roll-on rif. 03379

u.m.vta: 1  27

1 roll-on

REF. 03272

- Leistung: 15W
- 100-240 V~

- Potenza: 15W.
- 100-240V~

u.m.vta: 1  18

2 roll-on

REF. 03273

- Leistung: 30 W
- 100-240 V~

- Potenza: 30W.
- 100-240V~

u.m.vta: 1  13

3 roll-on



REF. 03274

- Leistung: 45W
- 100-240 V~

- Potenza: 45W.
- 100-240V~



Roll-on-Heizgerät mit Außenthermostat Riscaldatore roll-on con termostato esterno

u.m.vta: 1  9 



REF. 04091

- Leistung: 20 W
- Heizgerät mit Ladebasis für eine höhere Stabilität und Verwendung
- Fenster zur Anzeige des Wachsniveaus
- Regulierung der Temperatur von 1 bis 6
- Kabel des Ladegeräts 2 Meter
- Rasche Erwärmung und niedriger Verbrauch
- Schutzabdeckung
- Dank seines inneren Designs passt es sich an jeden Typ von Roll-on an
- LED-Wärmeanzeige
- 100-240 V~

- Potenza: 20W.
- Riscaldatore con base per una maggiore stabilità
- Finestrina per visualizzare il livello della cera
- Regolazione della temperatura da 1 a 6
- Cavo della base: 2 metri
- Riscaldamento veloce e consumi ridotti
- Coperchio di protezione
- Grazie al suo design interno si adatta a qualsiasi tipo di roll-on
- Spia LED di riscaldamento
- 100-240V~



1 Roll-on-Heizgerät + 1 Ladegerät mit magnetische Basis 1 riscaldatore roll-on + 1 base di ricarica con base magnetica

u.m.vta: 1  6 

REF. 06623





- Leistung: 20 W
- Fassungsvermögen: 100 g
- Frequenz: 50 Hz
- Spannung: 220-240 V~
- Ladegerät anschließbar an andere Ladegeräte (bis zu 5 Geräte)
- Seitliches Fenster zur Anzeige des Wachsniveaus
- Kontrollregler für die Temperatur (85°C máx)
- Leicht und von kleinen Abmessungen
- Mit Schutzkappe

- Potenza: 20W.
- Capacità: 100 gr
- Frequenza: 50Hz
- Voltaggio: 220-240V~
- Base collegabile ad altre basi (fino a 5 basi)
- Finestrina laterale per vedere il livello della cera
- Controllo del regolatore di temperatura (85°C max)
- Leggero e compatto
- Con cappuccio protettivo



Haarentfernung-Kits Pollié Kit per la depilazione Pollié

u.m.vta: 1  10 

REF.03310

Enthält · Contiene

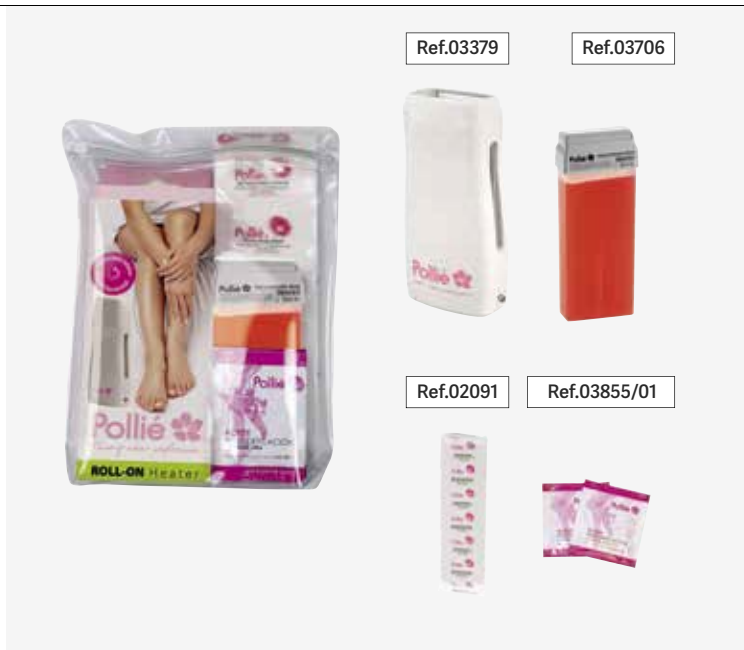

- 1 Roll-on-Heizgerät 15 W
- 1 Roll-on Argan
- 1 Pack mit 20 Haarentfernungstreifen
- 3 Öl-Pflegetücher Post-Haarentfernung

- 1 riscaldatore roll-on 15W
- 1 roll-on di argan
- 1 confezione da 20 strisce depilatorie
- 3 salviettine con olio post-depilazione



Die Haarentfernung-Kits Pollié sind ideal für eine einfache und bequeme Haarentfernung mit allem Notwendigen für die professionelle Depilation zu Hause. Zeigen Sie das ganze Jahr über schöne Beine.

I kit per la depilazione Pollié sono ideali per una depilazione facile e confortevole con tutto il necessario per la depilazione professionale a casa. Sfoggia delle belle gambe durante tutto l'anno.

u.m.vta: 1  9 

REF.03925

Enthält · Contiene

- 1 Roll-on-Heizgerät 20W
- 1 Roll-on Argan
- 1 Pack mit 20 Haarentfernungstreifen
- 3 Öl-Pflegetücher Post-Haarentfernung

- 1 riscaldatore roll-on 20W
- 1 roll-on di argan
- 1 confezione da 20 strisce depilatorie
- 3 salviettine con olio post-depilazione





Packs Papierstreifen zur Haarentfernung POLLIÉ
Pacchetti di strisce di carta depilatoria POLLIÉ

u.m.vta: 100 100

85 g/m²

REF.02091

- 20 Streifen
- 20 strisce

u.m.vta: 25 25

80 g/m²

REF. 00929

- 100 Streifen
- 100 strisce

u.m.vta: 25 25

90 g/m²

REF. 02556

- 100 Streifen
- Extra stark
- 100 strisce
- Extra forte



u.m.vta: 50 50

REF. 04207

- 100 Streifen
- 100 strisce





REF. 03804

- 100 Streifen
- 100 strisce

Rolle Haarentfernungspapier



Rotolo di carta depilatoria

u.m.vta: 1  12 80 g/m²

REF. 06926

- Breite; 7 cm
- Länge; 75 m

- Larghezza: 7 cm
- Lunghezza: 75 m

u.m.vta: 1  12 80 g/m²

REF. 03806



- Breite; 7 cm
- Länge; 100 m

- Larghezza: 7 cm
- Lunghezza: 100 m



Pack Papierstreifen zur Haarentfernung ANÓNIMAS

Pacchetti di strisce di carta depilatoria

u.m.vta: 100  100 80 g/m²

REF. 00929/00

100 Streifen
100 strisce

90 g/m²

REF. 02556/00

100 Streifen
Extra stark
100 strisce
Extra forte



80 g/m²

REF.03805

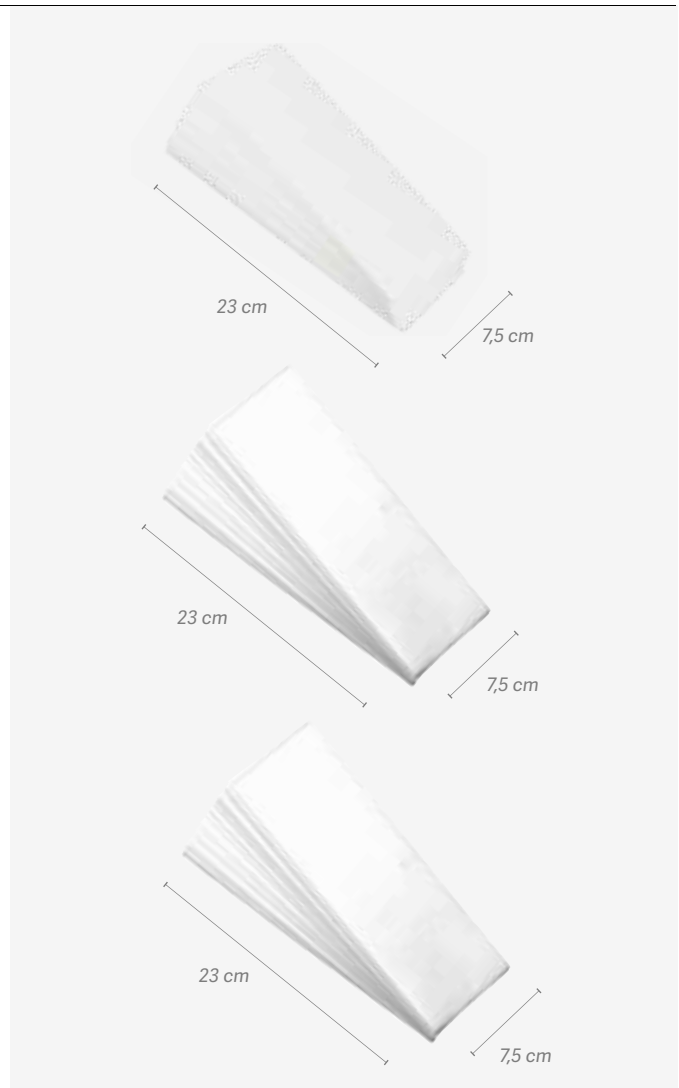
10 Streifen
10 strisce



Box mit 100 Papierstreifen zur Haarentfernung 90 Gramm hypoallergen
Confezione da 100 strisce di carta depilatoria 90 grammi ipoallergenica

u.m.vta: 1  28 

90 g/m²

REF. 06114



Extra: da es eine höhere Dichte besitzt, ist es stärker und widerstandsfähiger
 Eng geflochtene Fasern, die dem Produkt eine hohe Reißfestigkeit verleihen und als Barriere wirken, damit das Wachs nicht durchdringt

Extra: avendo più densità è più forte e più resistente

Fibre strettamente intrecciate che conferiscono al prodotto una totale resistenza allo strappo e fanno da barriera affinché la cera non penetri

Öl-Pflegetücher Post-Haarentfernung
Salviette con olio post depilazione

u.m.vta: 12  12

Beutel mit 5 Pflegetüchern
 Pacchetto da 5 salviette

2 ml

REF.03855

u.m.vta: 500  500

Unverpackt
 Sfuso

2 ml

REF.03855/01



Gel Post-Haarentfernung**Gel post depilazione**

u.m.vta: 1



6



500 ml

REF.07644

Sufgrund seiner regenerierenden und heilenden Wirkung ideal nach jeder Art der Haarentfernung, einschließlich Laser-Haarentfernung. Alle Hauttypen.

- Glättend und feuchtigkeitsspendend
- Regenerator
- Heilung

Ideale dopo ogni tipo di epilazione, compresa la depilazione laser, per la sua azione rigenerante e cicatrizzante. Tutti i tipi di pelle.

- Levigante e Idratante
- Rigeneratore
- Guarigione

Aloe Vera mit Calendula**Aloe Vera con calendula**

500 ml

REF.07645

Aufgrund seiner regenerierenden und heilenden Wirkung ideal nach jeder Art der Haarentfernung, einschließlich Laser-Haarentfernung.

Entzündungshemmende und antiseptische Eigenschaften. Alle Hauttypen.

- Feuchtigkeitsspendend
- regeneriert
- Heilung
- Entzündungshemmende Wirkung - Antiseptisch.

Ideale dopo ogni tipo di epilazione, compresa la depilazione laser, per la sua azione rigenerante e cicatrizzante.

Proprietà antinfiammatorie e antisettiche. Tutti i tipi di pelle.

- Idratante
- Rigenerante
- Guarigione
- Azione Antinfiammatoria - Antisettica.

Haarhemmer**Inibitore dei capelli**

500 ml

REF.07646

Es verlangsamt das Haarwachstum und lässt es schwächer werden. Es hat feuchtigkeitsspendende Eigenschaften. Alle Hauttypen.

- Verlangsamt das Haarwachstum.
- Es schwächt das neue Haar.
- Feuchtigkeitsspendend



Rallenta la crescita dei capelli e li rende più deboli. Ha proprietà idratanti. Tutti i tipi di pelle.

- Rallenta la crescita dei capelli.
- Indebolisce i nuovi capelli.
- Idratante

NEW



Gel Post-Haarentfernung
Gel post depilazione

u.m.vta: 1  6 



500 ml

- 99% aloe vera
- 99% di aloe vera

REF.03613



Öl Post-Haarentfernung
Olio post depilazione

u.m.vta: 1  6 

500 ml

- Mit Weinrose
- Rosenduft
- Con rosa mosqueta
- Profumo di rosa

REF.03614



Box 20 Kaltwachs-Streifen EMPFINDLICHE HAUT
Scatola da 20 strisce di cera fredda PELLI SENSIBILI

u.m.vta: 1  30

REF.03717

Enthaarungsstreifen für den Körper
Strisce per il corpo

u.m.vta: 1  40

REF.03718

Enthaarungsstreifen für das Gesicht
Strisce per il viso



Mit Beerenfrucht-Extrakten
Con estratti di frutti rossi



Box 50 konische Nadeln zur Haarentfernung Confezione da 50 aghi conici per depilazione

u.m.vta: 1  20

TIPO K

0,5 mm **Inox**

REF.02965

TIPO K

1 mm **Inox**

REF.02966

TIPO K

1,5 mm **Inox**

REF.02967

TIPO K

0,5 mm **Oro-Gold**

REF.02968

TIPO K

1 mm **Oro-Gold**

REF.02969

TIPO K

1,5 mm **Oro-Gold**

REF.02970



Haarentfernungsnadeln schräg Aghi per depil. Inclinati

u.m.vta: 1  20



TIPO K

1 mm **Inox**

REF.03287

- Box 50 Nadeln
- Confezione 50 aghi

Gerätereiniger aus Wachs Detergente per apparecchi depilatori

u.m.vta: 1  12 



500 ml

REF. 03437

- Lösungsmittel in Sprayform
- Für Schmelzer und Heizgeräte
- Solvente spray
- Per scaldacera e riscaldatori



Stromleitendes Gel neutral Gel elettroconduttivo neutro

u.m.vta: 1  4 

5 L

REF. 06694





Das Ultraschall-Übertragungsgel TASSEL ist zur Verbesserung der Leitfähigkeit für diagnostische und therapeutische Ultraschalluntersuchungen indiziert. Es ist im Wasser löslich und hinterlässt keine Flecken. Es kann mit allen auf dem Markt verfügbaren Ultraschallgeräten verwendet werden. Es ist einfach aufzutragen, gleichmäßig und ohne zu trocknen.

Das Ultraschall-Übertragungsgel TASSEL ist für den externen Gebrauch auf die intakte Haut und ohne Hautverletzungen gedacht. Tragen Sie das Gel an der zu behandelnden Stelle auf. Es ist ein hervorragendes Leitmittel für die Ultraschalltherapie, Diagnosebilder und die Laser-Haarentfernung.

Il gel per la trasmissione degli ultrasuoni TASSEL è indicato per migliorare la conduttività per gli ultrasuoni diagnostici e terapeutici. È solubile in acqua, non lascia macchie. Può essere utilizzato con tutti i dispositivi ad ultrasuoni disponibili sul mercato. Si stende facilmente, in modo uniforme e senza seccare.



Il gel per la trasmissione degli ultrasuoni TASSEL è destinato all'uso esterno su pelle intatta senza ferite cutanee. Applicare il gel sulla zona da trattare. È un eccellente agente conduttivo per la terapia a ultrasuoni, la diagnostica per immagini e la depilazione laser.

Stromleitendes Gel Gel elettroconduttivo

u.m.vta: 1  6 

1 L

REF. 07616



u.m.vta: 1  1 

5 L

REF. 07617

Talkum TASSEL

Talco TASSEL

u.m.vta: 1  6 

200 g

REF. 06429

Extrafeines parfümiertes Talkumpuder. Sanftheit, Frische und Nahrung für die Haut. Die Talkumpuder Tassel sind lindernd, feuchtigkeitsspendend und pflegend.

Ideal für nach der Rasur oder Haarentfernung, Reizungen oder wunde Stellen, Rötungen, Sonneneinwirkung oder Hautverletzungen. Ohne Allergene und ohne Parabene. Dermatologisch getestet.

- Absorbiert die Feuchtigkeit
- Hält die Haut frisch und trocken
- Lindert gereizte Haut
- Mildert

Talco extra fine profumato. Morbidezza, freschezza e nutrimento per la pelle. Il talco Tassel è ammorbidente, idratante ed emolliente.



Ideale per dopo la rasatura o la ceretta, irritazioni o prurito, arrossamenti, esposizione al sole o lesioni cutanee. Senza allergeni e senza parabeni. Dermatologicamente testato.

- Assorbe l'umidità
- Mantiene la pelle fresca e asciutta
- Lenisce la pelle irritata
- Ammorbidisce



Spender mit 100 Pollié-einweg-rasiermessern

Dispenser 100 macchinette per rasatura Pollié monouso

u.m.vta: 1  20 

REF. 07440

NEW





Speziell für Körperrasur konzipiert. Dank ihrer Schneide aus rostfreiem schwedischem Qualitätsstahl und dem Rasiererkopf mit Kammaufsatz ermöglichen diese die Enthaarung besonders sensibler Bereiche. Ideal für Laser-Enthaarung. Einfaches Ausspülen und Reinigen.

Appositamente progettato per la rasatura del corpo. Con la sua lama in acciaio inossidabile svedese di alta qualità e una testina con pettine, permette anche di radere i peli nelle parti più delicate. Ideale per la depilazione laser. Facile da sciacquare e pulire.

Box 100 Wegwerf-Rasiermesser Pollié

Confezione da 100 lamette usa e getta Pollié

u.m.vta: 1		7	
------------	---	---	---

REF. 02480



Beutel 5 Rasierhobel DERBY BODY

Busta 5 lamette DERBY BODY

u.m.vta: 14		112
-------------	---	-----

REF.03828

- Beutel mit 5 Rasierhobeln, mit Schutzkamm
- Speziell konzipiert zum Entfernen von Körperhaaren, denn der especial Schutzkamm sorgt für eine einfachere und sicherere Rasur bei längeren Haaren
- Ideal zur Verwendung für die Rasur vor der Laser-Haarentfernung
- Wird in Krankenhäusern für Rasuren vor einem chirurgischen Eingriff empfohlen
- Kopfteil und Griff aus Styropor
- Confezione da 5 lamette, con pettine protettivo
- Appositamente progettate per rimuovere i peli del corpo grazie allo speciale pettine protettivo che offre una rasatura più facile e sicura dei peli più lunghi
- Ideali da utilizzare per la rasatura prima della depilazione laser
- Consigliato negli ospedali per la rasatura prima dell'intervento chirurgico
- Testa e manico in polistirene



Beutel 5 Rasierhobel DERBY 2

Busta 5 lamette DERBY 2

u.m.vta: 40		40
-------------	---	----

Zwei Klingen
Due lame

REF.02948





Enthaarungspinzetten Pinzette depilatorie

Solingen

u.m.vta: 12  12

Nickel

REF.01080Kopfspitze
Punta convessa

8 cm

REF.00938Kopfspitze
Punta convessa

8 cm

REF.00937Kopfspitze
Punta convessa

8 cm

REF.01974Kopfspitze
Punta convessa

8 cm

REF.00939Kopfspitze
Punta convessa

9 cm

REF.01081Kopfspitze
Punta convessa

9 cm

REF.00940Kopfspitze
Punta convessa

9 cm



Enthaarungspinzetten
Pinzette depilatorie

Solingen

u.m.vta: 12 12

REF.02467

Feine Spitze
Punta fine



REF.02468

Schräge Spitze
Punta obliqua



REF.02469

Flache Spitze
Punta piatta



Inox

9,5 cm



u.m.vta: 12 12

REF.01402

Feine Spitze
Punta fine



REF.01403

Feine Spitze
Punta fine



REF.01404

Schräge Spitze
Punta obliqua



REF.01405

Flache Spitze
Punta piatta



Inox

9 cm



9,5 cm



9,5 cm



9,5 cm



Enthaarungspinzetten POLLIÉ
Pinzette depilatorie POLLIÉ

u.m.vta: 12  12

Kopfspitze
Punta convessa

REF.03205



REF.02625



REF.02626



REF.02627



Schräge Spitze
Punta obliqua

REF.02628



Flache Spitze
Punta piatta

REF.01340



REF.01341



REF.01339



REF.02793



REF.02794



REF.02795



REF.02796



Enthaarungspinzetten ANATOMICAL

Pinzette depilatorie ANATOMICAL

u.m.vta: 12  12

REF.02630 Schräge Spitze
Punta obliqua



9,5 cm

REF.02500 Schräge Spitze
Punta obliqua



10 cm

REF.02629 Flache Spitze
Punta piatta



9,5 cm

REF.02631 Feine Spitze
Punta fine



10 cm

Enthaarungspinzetten

Pinzette depilatorie

REF.02540/50 Schräge Spitze
Punta obliqua



9 cm

REF.02742/50 Schräge Spitze
Punta obliqua



9,5 cm

Enthaarungspinzetten schräg, farGrande

Pinzette oblique, colorate

u.m.vta: 12  12

Schräge Spitze
Punta obliqua



REF.02123

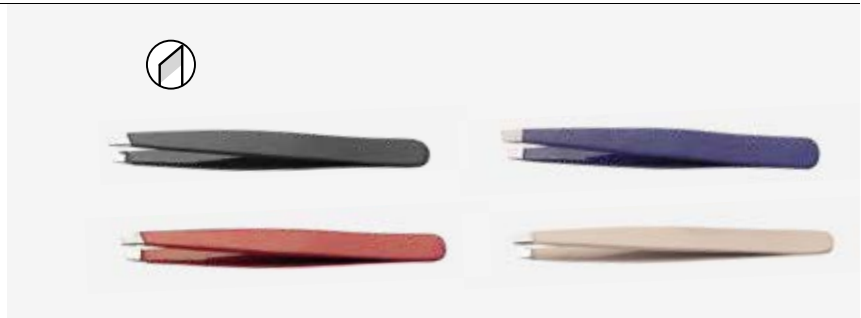

Schräge Spitze
Punta obliqua



REF.02499

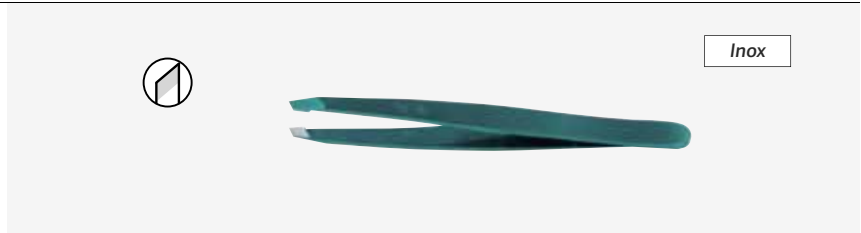

Schräge Spitze
Punta obliqua



REF.02744/50

REF.02744



Schräge Spitze
Punta obliqua



REF.02743/50

REF.02743



Schräge Spitze
Punta obliqua



REF.02742/50

REF.02742

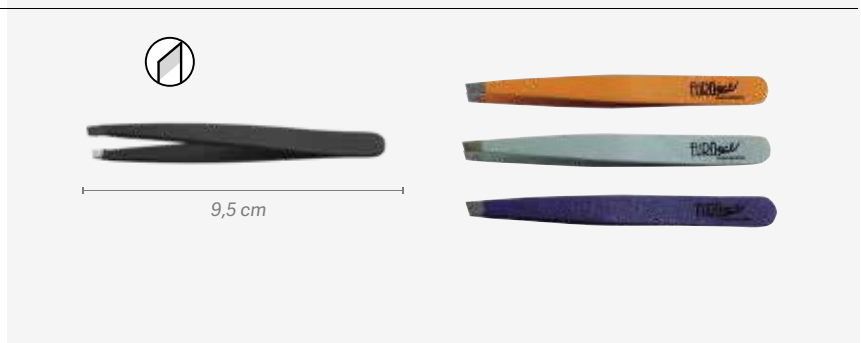

Verkaufsträger 24 Pinzetten schräg, farGrande 9,5 cm
Espositore 24 pinzette oblique colorate 9,5 cm

u.m.vta: 1  20

Schräge Spitze
 Punta obliqua

REF.03723



Verkaufsträger 24 Pinzetten mit Tieraufdruck 9,5 cm
Espositore 24 pinzette animalier 9,5

u.m.vta: 1  20

Schräge Spitze
 Punta obliqua

REF.03724



Verkaufsträger 24 Pinzetten schwarz 9 cm
Espositore 24 pinzette nere 9 cm

u.m.vta: 1  20

Schräge Spitze
 Punta obliqua

REF.03725



Nagellacke POLLIÉ · Smalti POLLIÉ

Wie lackiere ich meine Fingernägel? · Come applicare lo smalto

1. Eine Grundlage zum Schutz des Fingernagels auftragen
2. Vor Auftragen des farbigen Lacks ist es notwendig, den Inhalt ein wenig zu bewegen, allerdings in keinem Fall durch Schütteln von oben nach unten, da dies dazu führen kann, dass die Farbe Blasen auf Ihren Fingernägeln hinterlässt. Ideal ist es, den Flakon zwischen die Hände zu legen und horizontal drehen zu lassen. Wenn Sie den Lack auf die Fingernägel auftragen, ist es wichtig, dass Sie dies von der Mitte aus machen und ihn vertikal ausbreiten
3. Die Anwendung erfolgt mit wenig Lack auf dem Pinsel, beginnend von der Nagelhaut bis hin zur Spitze des Fingernagels, von unten nach oben
4. Damit der Lack so lange wie möglich hält, sollte das gewünschte Top Coat aufgetragen werden, das die Spitze versiegelt
5. Zum Schluss, Öl für die Nagelhaut und Handcreme auftragen

1. Applicare una base per proteggere l'unghia
2. Prima di applicare lo smalto colorato, è necessario agitare un po' il contenuto, anche se in nessun caso dovrete farlo scuotendolo dall'alto verso il basso, poiché questo farà sì che lo smalto lasci delle bolle sulle unghie. Il procedimento ideale è quello di prendere il flaconcino con la mano e farlo girare orizzontalmente. Quando applichi lo smalto sulle unghie, è importante farlo dalla metà e stenderlo in maniera verticale
3. L'applicazione verrà eseguita con una piccola quantità di smalto sul pennello, partendo dalla cuticola fino alla punta dell'unghia. Dal basso verso l'alto
4. Affinché lo smalto duri il più a lungo possibile, applicare il Top Coat desiderato, sigillando la punta
5. Per concludere, applicare l'olio per le cuticole e la crema per le mani

**Verkaufsträger Nagellack POLLIÉ
Espositore per smalti POLLIÉ**u.m.vta: 1  1

REF.03609

- 3 Lacke x 33 Farben = 99 Lacke insgesamt
- 1 farbige Karte
- Verkaufsträger
- 1 Poster
- 3 smalti x 33 colori = 99 smalti in totale
- 1 tavolozza colori
- Espositore
- 1 poster

**Nagellacke POLLIÉ
Smalti per le unghie POLLIÉ**u.m.vta: 3  3

12 ml

Solides Weiß
Bianco "solido"

REF.03505

Weiß
Bianco

REF.03507

Perlweiß
Bianco perla

REF.03503

Eis
Ghiaccio

REF.03501



Nagellacke POLLIÉ

Smalti per le unghie Pollié

u.m.vta: 3  3

12 ml

Beige
Beige

REF.03497



Sandfarben
Sabbia

REF.03513



Nackt-Rosa
Rosa nudo

REF.07426



Super nackt
Super nudo

REF.07424



Camel
Camel

REF.03422



Pastell-Rosa
Rosa pastello

REF.03495



Perlmutter-Rosa
Rosa perlato

REF.03494



Candy-Rosa
Rosa Candy

REF.04477



Kaugummi-Rosa
Rosa Bubblegum

REF.03496



Fuchsia-Rosa
Rosa fucsia

REF.03504



Amarant
Amaranto

REF.04479



Terrakotta
Terracotta

REF.03423



Remoulade
Barbabietola

REF.06239



Orange
Corallo

REF.03510



Fräser
Fragola

REF.03511



Passionsrot
Rosso passione

REF.03502



Kirschrot
Ciliegia

REF.07423



Nagellacke POLLIÉ

Smalti per le unghie POLLIÉ

u.m.vta: 3  3

Kirschrot
Rosso ciliegia

REF.03490



Metallic-Rot
Rosso metallizzato

REF.04295



Ganatot
Ganata

REF.03493



Schokolade
Cioccolato

REF.03491



12 ml

Gelb
Giallo

REF.03859



Golden
Dorato

REF.04085



Bronze
Bronzo

REF.03499



Pastell-Gün
Verde pastello

REF.04227



Smaragdün
Verde smeraldo

REF.03860



Meeresgün
Verde mare

REF.04569



Aquamaringün
Verde acquamarina

REF.04478



Jadegün
Verde Giada

REF.04294



Türkis
Turchese

REF.03509



Wacholdergün
Verde ginepro

REF.04570



Waldgün
Verde bosco

REF.03420



Nagellacke POLLIÉ

Smalti per le unghie POLLIÉ

12 ml

u.m.vta: 3  3

Urwaldgün
Verde giungla

REF.06240



Cyanblau
Blu ciano

REF.03861



Metallic-Türkis
Turchese
metallizzato

REF.04293



Metallic-Blau
Blu metallizzato

REF.03508



Indigoblau
Indigo

REF.04567



Perliges Lila
Viola perla

REF.03506



Pastell-Lila
Viola pastello

REF.04226



Amethyst
Ametista

REF.04568



Intensives Lila
Viola intenso

REF.07425



Violett
Violetto

REF.03421



Aubergine
Viola
melanzana

REF.04082



Silber
Argento

REF.04291



Mattgau
Gigio opaco

REF.03512



Schwarz
Nero

REF.03492



Silber glitzernd
Glitter argento

REF.04084



Farbig glitzernd
Glitter colorato

REF.04086



POLLIÉ Nagelbehandlungen
Trattamenti per unghie POLLIÉ

12 ml

u.m.vta: 3  3

Top Coat "matt" trocknend
 Top coat "opaco" essiccante

REF.03913



Top Coat "matt" trocknend
 Top Coat effetto "gel"

REF.04261



Top Coat. Glanz trocknend
 Top coat . Lucentezza essiccante

REF.03518



Vitaminreiche Gundlage
 Base vitaminica

REF.03514



Anti-Striemen
 Anti righe

REF.03515



Härter
 Indurente

REF.03516



Nagelhautentferner Gel
 Gel per rimuovere le cuticole

REF.03517



FLOUR-NAGELLACK
SMALTO UNGHIE FLUO

u.m.vta: 3  3

12 ml

NEW

Blau
 Blu

REF.07489



NEW

Rosa
 Rosa

REF.07490



NEW

Orange
 Arancione

REF.07491



NEW

Gelb
 Giallo

REF.07492



Karte Farbpalette Nagellack POLLIE

POLLIE nail polish colours chart

u.m.vta: 1  150

Umfasst 4 Farbräder
Include 4 rotelle con i colori

REF.06580

Spray zum Trocknen der Fingernägel

Spray per asciugare le unghie

u.m.vta: 1  12 

200 ml

REF.06693

Beschleunigt das Trocknen des Nagellacks, bringt seinen Glanz zur Geltung und verhindert dessen Abnutzung. Auf die gerade lackierten Fingernägel aufsprühen, bei getrennten Fingern und in einem Abstand von etwa 15 Zentimetern.

Accelera l'asciugatura dello smalto, ne esalta la lucentezza e previene il deterioramento della vernice. Nebulizzare sulle unghie dipinte di fresco, separando le dita e ad una distanza di circa 15 centimetri.

Kit Nagellacke "Back to basics"

Kit smalto "Back to basics"

u.m.vta: 1  6

4 x12 ml

REF.07154

Ref. 1ud - 03423
Ref. 1ud - 03501
Ref. 1ud - 03502
Ref. 1ud - 04477



Kit Nagellacke französische Maniküre

Kit smalto per manicure francese

u.m.vta: 1  6

4 x12 ml

REF.03863

Ref. 1ud - 01200 lima
Ref. 1ud - 00123 Baja pieles
Ref. 1ud - 03514
Ref. 1ud - 03495
Ref. 1ud - 03507
Ref. 1ud - 03528



SCHRITT FÜR SCHRITT NAGELACK P-LACK · PASSO PER PASSO SMALTO P-LACK

1. Eine feine Gundschrift P-Lack Base auftragen, ohne die Nagelhaut oder die Kontur des Fingernagels zu berühren. Den Rand des Fingernagels gut mit der gleichen Grundlage versiegeln. Diesen Vorgang an der ersten Hand durchführen und mit einer UV-Lampe 120 Sekunden oder mit einer LED-Lampe 90 Sekunden lang trocknen/polymerisieren. Mit der anderen Hand wiederholen.
2. Anschließend eine feine Schicht P-Lack Colour auftragen, ohne die Nagelhaut oder die Kontur des Fingernagels zu berühren. Den Rand des Fingernagels gut mit der gleichen Farbe versiegeln. Den Nagellack an der ersten Hand mit einer UV-Lampe 120 Sekunden lang oder mit einer LED-Lampe 90 Sekunden trocknen und polymerisieren. Den gleichen Vorgang an der anderen Hand wiederholen.
3. Eine zweite feine Schicht P-Lack Colour auftragen, unter Befolgung der gleichen Anweisungen wie bei der ersten Schicht. Es ist sehr wichtig, den Rand des Fingernagels gut zu versiegeln.
4. Für eine längere Haltbarkeit und ein perfektes, strahlendes Finish tragen wir eine feine Schicht P-Lack Gloss unter den gleichen Anweisungen wie in den vorangehenden Fällen auf.
5. Zum Schluss die klebrigen Reste entsorgen und die Fingernägel durch Befeuchten eines Pflagetuch aus Zellulose mit dem Nail Cleaner entfetten, Fingernagel für Fingernagel reinigen. Strahlendes Finish ohne dunkle Stellen.
6. Öl auf die Nagelhaut und Feuchtigkeitscreme auftragen

1. Applicare uno strato sottile di P-Lack base, senza toccare le cuticole o il contorno dell'unghia. Sigillare bene il bordo dell'unghia con la stessa base. Eseguire questa operazione nella prima mano e asciugare/polimerizzare con una lampada UV per 120 secondi o con una lampada LED per 90 secondi. Ripetere con l'altra mano.
2. Applicare in seguito uno strato sottile di P-Lack base, senza toccare le cuticole o il contorno dell'unghia. Sigillare bene il bordo dell'unghia con lo stesso colore. Eseguire questa operazione nella prima mano e asciugare e polimerizzare con una lampada UV per 120 secondi o con una lampada LED per 90 secondi. Ripetere la stessa operazione con l'altra mano.
3. Applicare un secondo strato sottile di P-Lack colour seguendo le stesse indicazioni del primo strato. È molto importante sigillare bene il bordo dell'unghia.
4. Per una durata maggiore con una finitura perfetta e brillante, applicare un sottile strato di P-Lack Gloss seguendo le stesse indicazioni dei casi precedenti.
5. Per finire: rimuovere i residui appiccicosi e sgassare le unghie inumidendo una salvietta in cellulosa con Nail Cleaner, pulire unghia per unghia. Finitura finale lucida senza zone opache.
6. Applicare olio sulle cuticole e crema idratante

Farbkarte P-lack Tavolozza colori P-lack



u.m.vta: 1	100
------------	-----

REF.06558



Semi-permanente Nagellacke P-LACK
Smalti semipermanenti P-LACK

9 g

u.m.vta: 1  6 



Dark Sky

REF.06247



Flames

REF.06246



Dark Rouge

REF.06245



Summer Fire

REF.06248



Violet Arrow

REF.06249



Rosa Candy

REF.06250



Barbies dress

REF.06251



Rosa Ribbon

REF.06253

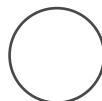

Pure Bianco

REF.06254



Verde Paradise

REF.06255



Clear Rosa

REF.06256



Clear Bianco

REF.06257



Chestnut

REF.06258



Baby Doll



REF.06262



Semi-permanente Nagellacke P-LACK

Smalti semipermanenti P-LACK

9 g

u.m.vta: 1  6 

Top Coat

REF.06260



Top coat no wipe

REF.07117



Base

REF.06261



Nero

REF.06244



Violet

REF.06592



Wine

REF.06593

French
Rosa

REF.06594



Red Ferrari

REF.06595



Violet

REF.07476

Neongün
Verde neon

REF.06942

Neonorange
Arancio neon

REF.06943

Neongelb
Giallo neon

REF.06944



Neonrosa
Rosa neon

REF.06945



Nail Primer POLLIÉ

Primer per unghie POLLIÉ

u.m.vta: 1  6 

7 ml

REF.06673

Nagellack zur Gewährleistung der perfekten Haftung des Gels und des Acryls. Enthält Säuren.

ANWENDUNG:

- 1. Die Fingernägel vorbereiten
- 2. Eine feine Schicht auftragen und an der Luft trocknen lassen
- 3. Aufbau-Gel oder Acryl auftragen und das Verfahren fortsetzen

Acid free

7 ml

REF.07116

Smalto per unghie per garantire la perfetta adesione di gel e acrilico. Contiene acidi.



COME USARE:

- 1. Prepara le unghie
- 2. Applicare uno strato sottile e lasciare asciugare all'aria
- 3. Applicare l'acrilico o il gel ricostruttivo e continuare con il processo



P-LACK Nagelvorbereitung

P-LACK Nagelvorbereitung

u.m.vta: 1  6 



15 ml

REF.07421



Nagellack Grundlage/Top Coat

Smalto per unghie base/top

u.m.vta: 1  6 

9 g

REF.06674

Produkt 2 in 1, transparent: Grundlage und Top Coat für das Acryl-Gel. Wird als Grundlage vor dem Acryl-Gel als Top für den Abschluss aufgetragen.

Prodotto trasparente 2 in 1: base e top per gel acrilico. Si applica come base prima del gel acrilico e poi come top per finire.



Acrylic gel

Acrylic gel

u.m.vta: 1  12

60 g

REF.06597

Transparentes Rosa
Rosa trasparente

60 g

REF.06598

Weiß
Bianco

60 g

REF.06599

Hell
Chiaro

60 g

REF.06600

Tarnfarbe
Mimetico

60 g

REF.06601

Intensives Rosa
Rosa intenso



Acryl-Gel ist die perfekte Kombination zwischen der Acryl- und der Gel-Technik

ANWENDUNG:

- Das Beste am Acryl: Kraft, Haltbarkeit und maximale Härte mit einer feineren Bearbeitung
- Das Beste an dem Gel: es ist flexibel, geruchslos, frei von Monomeren, sauber und leicht aufzufüllen. Verfügbar in 5 Farben



Acrylic Gel è la perfetta combinazione di tecniche acriliche e gel.

COME SI USA:

- Il meglio del gel: resistenza, durata e massima durezza con una scolpitura più fine
- La cosa migliore del gel: flessibilità, inodore, senza monomero, pulito e facile da riempire. Disponibile in 5 colori

P-LACK Nagelvorbereitung

Preparazione delle unghie P-LACK

u.m.vta: 1  16 

REF.07422

Nagellackentferner P-LACK

Solvente per unghie P-LACK

REF.06263

- Reines Azeton
- Orangen-Parfüm
- Acetone puro
- Profumo d'arancia

Nagelreiniger P-LACK



Detergente per unghie P-LACK

REF.06283



Nagellackentferner ölig, rosa

Solvente per unghie oleoso rosa

u.m.vta: 1  19 

150 ml

REF.06608

Nagellackentferner mit Azeton, angereichert mit Rizinusöl. Entfernt den Lack auf sanfter Weise von den Fingernägeln, gibt ihnen Glanz und parfümiert sie

Solvente acetone arricchito con olio di ricino. Rimuove delicatamente lo smalto dalle unghie, lasciandole lucide e profumate

Nagellackentferner ohne Azeton



Solvente per unghie senza acetone

u.m.vta: 1  19

150 ml

REF.07172

Mit Rizinusöl, das die Nagelhaut hydratisiert
Con olio di ricino per idratare le cuticole

u.m.vta: 1  12 

1 L

REF.06607

- Mit Azeton
- Con acetone



u.m.vta: 1  12



1 L

REF.07173

- Acetonfrei
- Senza acetone





Nagellackentferner P-LACK
Solvente per unghie P-LACK

u.m.vta: 1  19 

150 ml

REF.07109





u.m.vta: 1  12 

1 L

REF.07110



Nagelreiniger (Reiniger / Entfetter)
Detergente per unghie (detergente / sgrassante)

u.m.vta: 1  19 

150 ml

REF.07111



u.m.vta: 1  24 

400 ml

REF.07112

Dose 10 einzelne Fingeranfeuchter Confezione da 10 ditali per ammollo

u.m.vta: 1  12

REF.03879

- Nicht mit Nagellackentferner ohne Azeton verwenden
- Non utilizzare con solvente per smalto senza acetone



Folien zur Nagellackentfernung 100 Stück Fogli laminati avvolgenti per rimozione 100 unità

u.m.vta: 1  107

100 u



REF.04824

Silberpapierfolien aus Aluminium mit Watte, für eine einfache und bequeme Anwendung mit dem Nagellackentferner oder mit Azeton auf den Fingernägeln.

Fogli di alluminio laminato con cotone incorporato per essere facili e comodi da applicare con il solvente o l'acetone sull'unghia.



Handcreme ultra-feuchtigkeitsspendend nahrhaft Crema per le mani nutriente ultra idratante

u.m.vta: 1  6 

Mit Dosierer
Con dosatore

500 ml

REF.07083

Eine Ultra-Feuchtigkeitscreme, nahrhaft, ohne fettiges Gefühl an den Händen in einem sanften, aber kräftigen Schutzschleier.

Weinrosenöl erweist sich als sehr wirkungsvoller Regenerator für unsere Haut

- Es wirkt oberflächlich zur natürlichen Befeuchtung und zur Verbesserung der Hydratation
- Sorgt für Nährstoffe und regeneriert
- Reduziert den Wasserverlust in unserer Epidermis, da es die Ceramid-Barriere stärkt und erhöht
- Korrigiert und verhindert Probleme der Haut aufgrund von Lichtalterung, durch die Selbsterzeugung von Melanin
- Kräftigt den Fibroblast, die Hautzelle, die das Kollagen erzeugt, Hyaluronsäure, Elastin und verantwortlich für die Festigkeit und Elastizität unserer Haut

u.m.vta: 1  17 

100 ml

REF.07082

Una crema ultra idratante e nutriente non grassa che avvolge le mani in una morbida e potente pellicola riparatrice. L'Olio di rosa mosqueta risulta essere un potentissimo rigeneratore per la nostra pelle

- Agisce in superficie come fattore idratante naturale, migliorando l'idratazione.
- Nutre e rigenera
- Riduce la perdita di acqua della nostra epidermide, poiché rinforza e moltiplica la barriera di ceramidi
- Corregge e previene i problemi cutanei dovuti al fotoinvecchiamento, attraverso l'autogenerazione della melanina.
- Rin vigorisce il fibroblasto, che è la cellula dermica che produce collagene, acido ialuronico, elastina ed è responsabile della compattezza e dell'elasticità della nostra pelle



Lüfterbürste mit Kunsthaar
Pennelli a ventaglio con pelo sintetico

u.m.vta: 1 12

REF.07097



REF.07098



- Groß
- Grande

Nagelpinsel für Acrylnägel Kolinsky
Pennelli per unghie acriliche Kolinsky

u.m.vta: 1 12

- Marderhaar

Gilt als bestes Haar bei Pinseln für Acrylnägel aufgrund seiner Widerstandskraft und Haltbarkeit, seiner hohen Elastizität und der maximalen Absorption des Produkts.

- Setole di zibellino

Considerato il miglior pelo per pennelli per unghie acriliche per la sua resistenza e durata, per la sua Grande elasticità e il massimo assorbimento del prodotto.



N°2

REF.03659

N°4

REF.03660

N°6

REF.03661

N°8

REF.03662

N°10

REF.07648

N°12

REF.07649

NEW

NEW

Nagelpinsel für Gel
Pennelli per unghie gel

u.m.vta: 1 12



N°2

REF.03654

N°4

REF.03655

N°6

REF.03656

N°8

REF.03657

N°10

REF.03658

N°12

REF.07647

NEW

Gel wird auf die Fingernägel nicht mit dem normalen Nagelpinsel von Kolinsky aufgetragen, das für Acrylnägel verwendet wird. Denken Sie daran, je höher die Anzahl Ihrer Pinsel ist, desto höher ist deren Dicke.

Wenn Sie die Fingernägel mit Gel behandeln möchten, müssen Sie Spezialpinsel verwenden, die Ihnen das Auftragen des Gels erleichtern. Denn Gel verhält sich anders als Acryl. Aus diesem Grunde werden sehr unterschiedliche Pinsel verwendet.

Heute sind die Pinsel für das Auftragen von Gel aus Nylon (synthetisch). SYNTHETISCHE HAARE, ZWINGE AUS ALUMINIUM, GIFF AUS HOLZ

Le unghie di gel non vengono fatte con il solito pennello di pelo kolinsky che viene utilizzato per le unghie acriliche. Ricorda, più Grande è il numero sul pennello, più Grande sarà lo spessore del pennello stesso.

Se vuoi scolpire le unghie in gel, devi usare pennelli speciali che ti facilitano il posizionamento del gel. Questo perché il gel è diverso dall'acrilico. Per questo motivo vengono utilizzati pennelli molto diversi.

Attualmente i pennelli utilizzati per applicare il gel sono in nylon (sintetici). SETOLE SINTETICHE, GHIERA IN ALLUMINIO, MANICO IN LEGNO

Satz mit 6 Pinseln zur Fingernagel-Dekoration Set da 6 pennelli per decorazione unghie



u.m.vta: 1  12

Synthetisches Haar
Setole sintetiche

REF.03653



Pinsel für Gel + Stößel für Nagelhaut Pennello per gel + spingi cuticole



u.m.vta: 1  12 

REF.06760



Nail art

Pinsel „Dotting“ für Fingernägel Pennello dotting per unghie



u.m.vta: 1  12 

REF.06761



Nail art

Pinsel „Gradient“ für Fingernägel Pennello gradiente per unghie

u.m.vta: 1  12 



4 Austauschspitzen
4 punte di ricambio

REF.06762



Nail art

Pinselständer, schwarz Portapennelli nero

u.m.vta: 1  12 

REF.04822



Satz Nail Art Set nail art

u.m.vta: 1  42

REF.06759

- 15 Pinsel für Fingernägel
- 5 Pinsel mit doppelter Metallspitze

- 15 pennelli per unghie
- 5 a doppia punta in metallo





Original für Maniküre Manicure originali



Mit den Punzen können Sie die Fingernägel dekorieren und eine Vielzahl von Formen, Linien, Punkte, Blumen kreieren, alle in verschiedene Farben. Die Pinsel mit feiner Spitze helfen Ihnen, diese kleinen Details aufzutragen, die aus Ihren Fingernägeln ein kleines Kunstwerk machen.

Con i punzoni puoi decorare le unghie e realizzare innumerevoli forme, linee, punti, fiori, tutti in diversi colori. I pennelli a punta fine ti aiuteranno a realizzare quei piccoli dettagli che renderanno le tue unghie una piccola opera d'arte.



Satz 5 Punzen zur Dekoration der Fingernägel Set da 5 punzoni per decorare le unghie

u.m.vta: 1  12 

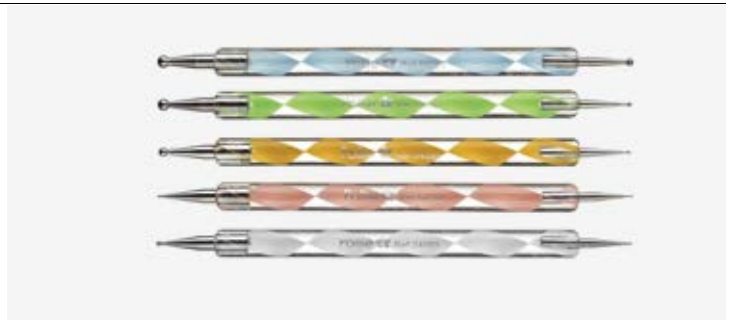
REF.04093



Strass Rhinestone Nail Art Rad Disco strass per nail art



u.m.vta: 1  12 

600 u

REF.06774





Fimo Nail Art Blumen und Obst Rad Disco Fimo per nail art fiori e frutti

u.m.vta: 1  12 

144 u

REF.04835



Strass Rhinestone Farben Nail Art Rad*Disco strass colori per nail art*u.m.vta: 1  12 

- Mini
- Mini

600 u

REF.07347



600 u

REF.07345

**Strass Rhinestone Silber- Nail Art Rad***Disco strass argento per nail art*

144 u

REF.07346

**Donuts rhinestones nail art rueda***Ciambelle strass nail art rueda*

144 u

REF.07342

**Sequins rhinestones nail art wheel***Per nail art con paillettes strass*

144 u

REF.07343



**Friedens- und Liebeskarussell***Giostra della pace e dell'amore*

144 u

REF.07352



3D-Aufkleber Adesivi 3D

u.m.vta: 1  12 

- Weiße Herzen
- Cuori bianchi

REF.04831



- Weiße Schmetterlinge
- Farfalle bianche

REF.04832



- Weiße Blumen
- Fiori bianchi

REF.04833





- Farbige Blumen
- Fiori colorati

REF.04834



Folie Nail Art 1,5 m Lamina per nail art 1,5 m

u.m.vta: 1  12 



REF.06770 Schwarz
Nera

REF.06768 Golden
Dorata

REF.06769 Silber
Argentata



Klebeband für Fingernägel 0,8 mm Nastro adesivo per unghie 0,8 mm

u.m.vta: 1  12 Schwarz
Nera

REF.06773

Golden
Dorata



REF.06771

Silbern
Argentata

REF.06772



Dekoration für Nail Art Decorazione per nail art

u.m.vta: 1  12 Trockenblumen. 12 Farben
Fiori secchi. 12 colori

REF.06763

Verschiedene Glitter. 1 g x 12 Farben
Assortimento di glitter. 1 g x 12 colori

REF.06764



REF.06765

- Sortiment Samtpulver
- 0,5 g x 12 Farben
- Polveri vellutate assortite
- 0,5 g x 12 colori

REF.06766



- Sortiment Samtpulver
- 1 g x 12 Farben
- Glitter squame di sirena
- 1 g x 12 colori

REF.06767

- Blattgold 12 Farben
- Foglia d'oro in 12 colori



Dekoration für Nail Art Decorazione per nail art

u.m.vta: 1  12 

REF.07344

- Mikrokristall-Kaviar-Nagelkunstkugeln
- 1,5 g x 12
- *Palline per nail art al caviale micro cristallo*
- 1,5g x 12



REF.07348

- Glitter pulver glitter nail art
- 1,5g x12 farben
- *Polvere glitter glitter nail art*
- 1,5 g x 12 colori



REF.07349

- Nail Art Sandpulver
- 1,5 g x 12 Farben
- *Polveri di sabbia per nail art*
- 1,5 g x 12 colori



REF.07350

- Verschiedene Glitzer Nail Art Glitter
- 1,5 g x 12 Farben
- *Glitter assortiti nail art glitter*
- 1,5 g x 12 colori



REF.07351

- Glitzerflocken-Rauten
- 1,5 x 12 g
- *Rombi fiocchi glitterati*
- 1,5 x 12 g



REF.07382

Perlglanz-nagelkunstpalette
Tavolozza per unghie perlescente



Nagelform für Fingernägel Stampo per unghie

u.m.vta: 1	 32	u.m.vta: 1	 21
------------	--	------------	--

500 u

REF.04825

500 u

REF.04827



- Rechteckig
- Rettangolare

- Hufeisen mittel
- Ferro di cavallo medi



- Doppelte Dicke
- Doppio spessore

u.m.vta: 1	 57
------------	--

500 u

REF.04826



Transparenter Dispenser für Nagelformen Dispenser trasparente per stampi per unghie

u.m.vta: 1	 4	
------------	---	---

REF.04828



Wiederverwendbare Nagelformen Stampi per unghie riutilizzabili

u.m.vta: 1	 12	
------------	--	---

5 u

REF.06750



Schablonen für French Manicure
Guide per manicure francese

u.m.vta: 1  50

REF.04829

- Formen
- *Forme*



REF.04830



Fingernageltips
Tip per unghie

u.m.vta: 1  46

100 u

REF.06743

- Natürlich
- *Naturali*



100 u

REF.06744

- Natürlich rund
- *Curve naturali*



100 u

REF.06745

- Weiß eckig
- *Bianche quadrate*



100 u

REF.06746

- Weiß eckig
- *Bianche curve*



100 u

REF.06747

- Transparent eckig
- *Trasparenti quadrate*





100 u

REF.06748

- Transparent rund
- *Trasparenti curve*



Mischpalette für nail art aus plastik
Palette per miscelazione plastica per nail art



u.m.vta: 1  50 

REF.07477

NEW



Mischpalette für nail art aus metall
Palette per miscelazione metallica per nail art



u.m.vta: 1  50 

REF.07478

NEW



Beutel 10 Paletten für Demo
Confezione 10 palette per demo



u.m.vta: 1  15 

Natürlich
 Naturale

REF.06751

06751



u.m.vta: 1  15 



Transparent
 Trasparente

REF.06752

06752





Künstliche Hand für Manikürepraxen Mano articolata per esercitazioni di manicure

u.m.vta: 1		10	
------------	---	----	---

REF.07080



Ersatzteil Ricambio

u.m.vta: 1		12	
------------	---	----	---

REF.07081

- Beutel 100 Fingernägel für künstliche Hände
- Confezione da 100 unghie per mano articolata

Weiche Hand für Manikürepraxen Mano morbida per esercitazioni manicure

u.m.vta: 1		50
------------	---	----

REF.04356

- Geeignet zum Trocknen von Lampen
- Adatto per lampade di asciugatura





u.m.vta: 1		20
------------	---	----

REF.04353

- Geeignet zum Trocknen von Lampen
- Mit Ständer
- Adatto per lampade di asciugatura
- Con supporto

Vorgeschnittene Zellulose Cellulosa pretagliata

u.m.vta: 1	 12	
------------	--	---

REF. 03060



- Anonym
- Anonimo

REF. 03060/00



Beutel mit 2 Rollen vorgeschnittener Zellulose in Stücken von 4 x 5 cm. Jede Rolle besteht aus 500 Stück absorbierender Pflaster. Ideal zur Entfernung von Nagellack, ohne Flusen zu hinterlassen. Ø 15 · Gewicht: 155 g, Toleranz 15 g

Busta con 2 rotoli di cellulosa pretagliati in pezzi di 4 x 5 cm. Ogni rotolo è di 500 unità assorbenti. Ideale per rimuovere lo smalto dalle unghie senza lasciare tracce di pelucchi. Ø 15 Peso: 155 g Tolleranza 15 g

Dispenser + 1000 Pad Nail

Dispenser + 1000 pad nail

u.m.vta: 1	 12
------------	--

REF.06471



Vorgeschnittene kleine Quadrate, bequem zu benutzen, ohne Flusen zu hinterlassen. Ideal zur Entfernung von Nagellack mit Azeton oder der klebrigen Schicht von semi-permanentem Lack.

Quadretti pretagliati comodi da usare poiché lasciano pelucchi. Ideale per rimuovere lo smalto con acetone o lo strato appiccicoso del semipermanente.



Abdeckband

Nastro protettivo

u.m.vta: 1	 12	
------------	--	---



- Rosa
- Rosa

REF.06757



Godet Tube 5 Stück

Bicchierini in plastica 5 u.



u.m.vta: 1	 12	
------------	--	---

- Kunststoff
- Plastica

REF.06758



Gläser für Maniküre Bicchieri per manicure

u.m.vta: 1  160 

- Glas
- Cristallo

REF.06756



Keramikbehälter Korkdeckel Contentitore in ceramica con tappo in sughero

u.m.vta: 1  48

- Weiß
- Bianco

REF.06775



Clips Soak-off-Entferner 10 Stück Clip remover da ammollo 10 u

u.m.vta: 1  106

- Weiß
- Bianco

REF.06777





- Rosa
- Rosa

REF.06778



Lampe für Fingernägel UV-LED 65w, Modell: Silver LIGHT Lampada per unghie UV-LED da 65w modello: Silver LIGHT

u.m.vta: 1  12 

REF. 07186

SCAN
ME!

- Leistung 65 W
- Gewicht: 450 g
- UV-LED-Lampen: 33 Stück
- Wellenlänge LEDs: 395- 405 nm
- Spannung: 100 – 240 V
- Frequenz 50/60 Hz
- Timer: 10, 30, 60 und 99 Sekunden
- Ausgang Adapter: DC 24 V = 2A
- Betriebstemperatur: -10°C – 35°C
- Abnehmbare magnetische Metallunterlage.



- Potenza: 65 W.
- Peso: 450 g
- LED UV: 33 unità
- Lunghezza d'onda LED: 395- 405nm
- Voltaggio: 100 – 240V
- Frequenza 50/60 Hz
- Timer: 10", 30", 60" e 99" secondi
- Uscita trasformatore: DC 24V = 2A
- Temperatura operativa: -10°C -35°C
- Base magnetica estraibile in metallo.



Wir präsentieren Ihnen unsere UV-LED-Lampen mit 48 W (Ref.-Nr. 06638, Modell MOON LIGHT und 06639 Modell SUN LIGHT). Sie sind die ideale Ergänzung für das rasche und sichere Trocknen von semi-permanentem Nagellack und Aufbau-Gels in der Maniküre/ Pediküre, insbesondere für Lacke, für die das Trocknen mit LED-Lampen vorgesehen ist.

Vi presentiamo le nostre lampade UV LED da 48W (Rif.06638 modello MOON LIGHT e 06639 modello SUN LIGHT), sono il complemento ideale per una asciugatura rapida e sicura di smalti semipermanenti e gel di ricostruzione in manicure/pedicure, nonché appositamente pensate per l'asciugatura a LED

Lampe für Fingernägel UV-LED 48w, Modell: MOON LIGHT Lampada per unghie UV-LED da 48w modello: MOON LIGHT

u.m.vta: 1  12 

REF. 06638





SCAN ME!

- Leistung: 48 W
- Gewicht: 450 g
- UV-LED-Lampen: 21 Stück
- Wellenlänge LEDs: 395- 405 nm
- Spannung: 100 – 240 V
- Frequenz 50/60 Hz
- Timer: 30, 60 und 99 Sekunden
- Ausgang Adapter: DC 24 V 1,5 A
- Betriebstemperatur: -10°C – 35°C

- Potenza: 48 W.
- Peso: 450 g
- LED UV: 21 unità
- Lunghezza d'onda LED: 395- 405nm
- Voltaggio: 100 – 240V
- Frequenza 50/60 Hz
- Timer: 30", 60" e 99" secondi
- Uscita trasformatore: DC 24V 1,5A
- Temperatura operativa: -10° -35°C

Lampe für Fingernägel UV-LED 48W, Modell: SUN LIGHT Lampada per unghie UV-LED da 48W modello: SUN LIGHT

u.m.vta: 1  8 

REF. 06639



SCAN ME!

- Leistung: 48 W
- Gewicht: 560 g
- UV-LED-Lampen: 24 Stück
- Wellenlänge LEDs: 395-405 nm
- Spannung: 100 – 240 V~
- Frequenz 50/60 Hz
- Timer: 10, 30, 60 und 99 Sekunden
- Ausgang Adapter: DC 24V 1.5A
- Betriebstemperatur: -10°C – 35°C
- Abnehmbarer Standfuß



- Potenza: 48 W.
- Peso: 560g
- LED UV: 24 unità
- Lunghezza d'onda Led: 395-405 nm
- Voltaggio: 100 – 240V~
- Frequenza 50/60 Hz
- Timer: 10" 30", 60" e 99" secondi
- Uscita trasformatore: DC 24V 1.5A
- Temperatura operativa: -10°C -35°C
- Base staccabile

Wir präsentieren Ihnen unsere UV-LED-Lampen mit 48 W (Ref.-Nr.-Nr. 06640, Modell POWER LIGHT und 06641 Modell FAST LIGHT). Sie sind die ideale Ergänzung für das rasche und sichere Trocknen von semi-permanentem Nagellack und Aufbau-Gels in der Maniküre/Pediküre, insbesondere für Lacke, für die das Trocknen mit LED-Lampen vorgesehen ist.

Vi presentiamo le nostre lampade UV LED da 48W (Rif.06640 modello POWER LIGHT e 06641 modello FAST LIGHT), sono il complemento ideale per una asciugatura rapida e sicura di smalti semipermanenti e gel di ricostruzione in manicure/pedicure, nonché appositamente pensate per l'asciugatura a LED.

Lampe für Fingernägel UV-LED 48W, Modell: POWER LIGHT

Lampada per unghie UV-LED da 48W modello: POWER LIGHT

u.m.vta: 1  8 

REF. 06640

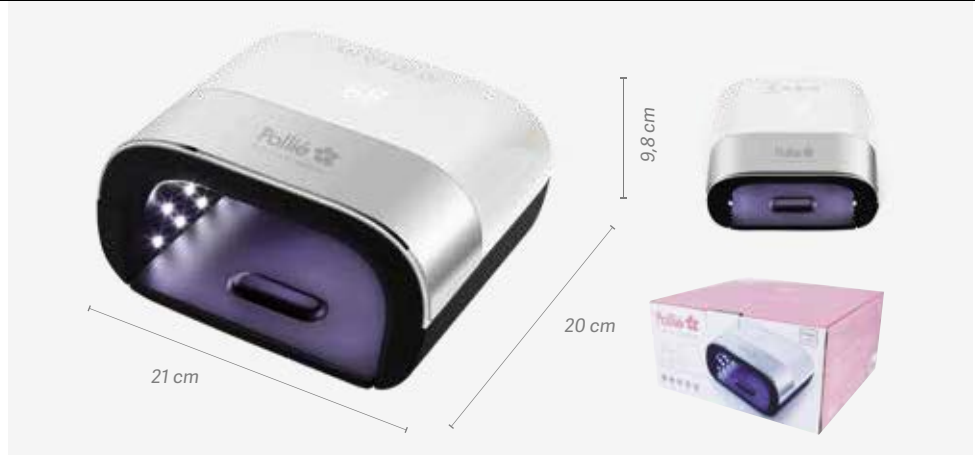

SCAN
ME!

- Leistung: 48 W
- Gewicht: 880 g
- LED/UV-Perlen: 36 Stück
- Wellenlänge LEDs: 395-405 nm
- Spannung: 100 – 240 V~
- Frequenz 50/60 Hz
- Timer: 30, 60 und 99 Sekunden
- Ausgang Adapter: DC 24V 1,5A
- Betriebstemperatur: -10°C – 35°C
- Abnehmbarer Standfuß
- Für Maniküre und Pediküre

- Potenza: 48 W.
- Peso: 880 g
- Led UV: 36 unità
- Lunghezza d'onda Led: 395-405 nm
- Voltaggio: 100 – 240V~
- Frequenza 50/60 Hz
- Timer: 30", 60" e 99" secondi
- Uscita trasformatore: DC 24V 1,5A
- Temperatura operativa: -10°C – 35°C
- Base staccabile
- Per manicure e pedicure

Lampe für Fingernägel UV-LED 48W, Modell: FAST LIGHT

Lampada per unghie UV-LED da 48W modello: FAST LIGHT

u.m.vta: 1  8 

REF. 06641

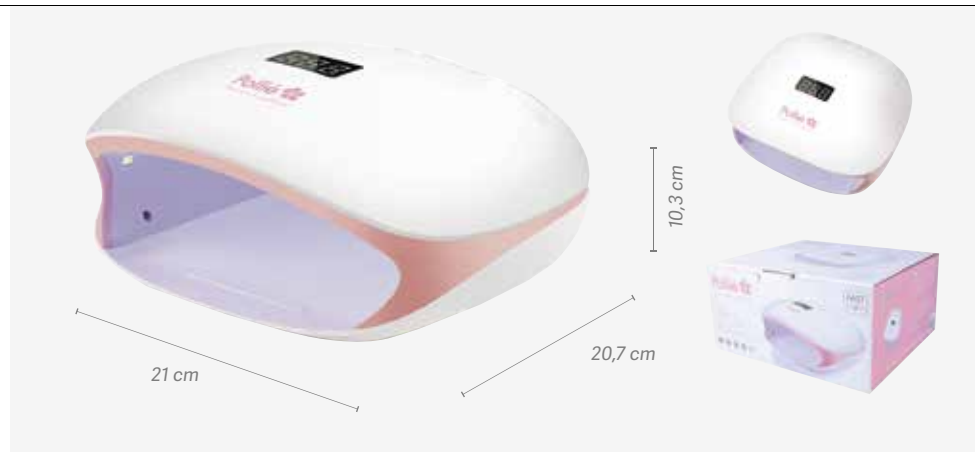

SCAN
ME!

- Leistung: 48 W
- Gewicht: 740 g
- LED/UV-Perlen: 36 Stück
- Wellenlänge LEDs: 395-405 nm
- Spannung: 100 – 240 V~
- Frequenz 50/60 Hz
- Timer: 10, 30, 60 und 99 Sekunden
- Ausgang Adapter: DC 24V 1.5A
- Betriebstemperatur: -10°C – 35°C
- Abnehmbarer Standfuß



- Potenza: 48 W.
- Peso: 740 g
- Led UV: 36 unità
- Lunghezza d'onda LED: 395-405 nm
- Voltaggio: 100 – 240V~
- Frequenza 50/60 Hz
- Timer: 10" 30"; 60" e 99" secondi
- Uscita trasformatore: DC 24V 1.5A
- Temperatura operativa: -10°C – 35°C
- Base staccabile

Wir präsentieren Ihnen unsere LED-Lampen mit 24 W (Ref.-Nr.-Nr. 04919 Modell STAR LIGHT (und 48 W (Ref.-Nr.-Nr. 04920 Modell ENERGY LIGHT), sie sind die ideale Ergänzung für das rasche und sichere Trocknen von semi-permanentem Nagellack und Aufbau-Gels in der Maniküre/Pediküre, insbesondere für Lacke, für die das Trocknen mit LED-Lampen vorgesehen ist.

Vi presentiamo le nostre lampade LED da 24W (rif. 04919 modello STAR LIGHT) e da 48W (rif. 04920 modello ENERGY LIGHT). Sono il complemento ideale per asciugare smalti semipermanenti e gel di ricostruzione in manicure e pedicure, oltre a quelli appositamente formulati per l'asciugatura a LED.

LED-UV-Lampe 24W STAR LIGHT Lampada led UV STAR LIGHT 24W

STAR Light

u.m.vta: 1  12 

REF. 04919



SCAN ME!





- Potenza: 24W.
- LED/UV: 15 unità
- Lunghezza d'onda LED: 395-405 nm
- Voltaggio: 100-240V~
- Frequenza 50/60 Hz
- Timer: 10" 30", 60" e 99" secondi
- Base staccabile per manicure e pedicure

- Leistung: 24W
- LED/UV-Perlen: 15 Stück
- Wellenlänge LEDs: 395-405 nm
- Spannung: 100-240 V~
- Frequenz 50/60 Hz
- Timer: 10, 30, 60 und 99 Sekunden
- Abnehmbarer Standfuß für Maniküre und Pediküre

LED-UV-Lampe 48W ENERGY LIGHT Lampada LED UV ENERGY LIGHT 48W

ENERGY Light

u.m.vta: 1  12 

REF. 04920



- Leistung: 48 W
- LED/UV-Perlen: 24 Stück
- Wellenlänge LEDs: 395-405 nm
- Spannung: 100-240 V~
- Frequenz 50/60 Hz
- Timer: 10, 30, 60 und 90 Sekunden
- Abnehmbarer Standfuß für Maniküre und Pediküre

- Potenza: 48 W.
- LED/UV: 24 unità
- Lunghezza d'onda LED: 395-405 nm
- Voltaggio: 100-240V~
- Frequenza 50/60 Hz
- Timer: 10" 30", 60" e 90" second
- Base staccabile per manicure e pedicure

Ersatzlampen · Ricambi lampadine

9W UV
9W UV

REF. RE03150/01

9W UV led
9W UV led

REF. RE04354/02

Mini-LED-Lampe 2W tragbar USB
Mini lampada LED USB portatile da 2W

u.m.vta: 1		72	
------------	--	----	--

REF. 04355



- Leistung: 2W
- Speziell für Fingernägel mit Gel, semi-permanenten Lack
- UV-Licht 365 nm
- Timer 10"
- USB-KABEL INBEGRIFFEN
- Ideal für die Reise und den Transport wegen seines kleinen Taschenformats

- Potenza: 2W.
- Speciale per unghie in gel, smalto semipermanente
- Luce UV 365 nm
- Timer 10"
- CAVO USB INCLUSO
- Ideale per viaggiare e da trasportare grazie alle sue piccole dimensioni tascabili



Spa für Maniküre

Spa manicure

u.m.vta: 1  24

REF. 04265

- Leistung: 2W
- Batterie nicht inbegiffen
- Stimulierende Sprudelmassage vor der Maniküre, die die Nagelhaut entspannt
- Spannung: 100-240 V~
- Frequenz 50/60 Hz

- Potenza: 2W.
- Batteria non inclusa
- Massaggio stimolante pre-manicure con bollicine che ammorbidiscono le cuticole
- Voltaggio: 100-240V~
- Frequenza 50/60 Hz



Staubsauger für Maniküre

Aspirapolvere per manicure

u.m.vta: 1  8 

REF. 04205

Tischsauger für den Staub der Maniküre, elegant und sehr funktional. Modernes, neuartiges Design. Saugt den Staub, der beim Nagelfeilen der Fingernägel entsteht, perfekt ab. Der Staub wird schließlich in einem passenden Beutel entsorgt, womit das Einatmen von Staubresten verhindert wird.

- Leistung: 23W
- Batterie nicht inbegiffen
- Mit 3 Austauschbeuteln

Aspiratore da tavolo per la polvere della manicure, elegante e molto funzionale, dal design moderno e innovativo. Raccoglie perfettamente la polvere che si forma durante l'affilatura delle unghie. Grazie al tornio, la polvere va sotto l'aspirapolvere, in un apposito sacchetto, evitando così di respirare residui di polvere.

- Potenza: 23W.
- Batteria non inclusa
- Con 3 sacchetti di ricambio



Paraffin: hydratisiert, nahrhaft für Ihre Hände und Füße**Paraffina: idrata e nutre mani e piedi**

u.m.vta: 1



- Hydratisiert in der Tiefe
- Verbessert sichtbar das Aussehen der Haut
- Macht die Haut elastischer
- Verbessert die Mikrozirkulation des Blutes
- Begünstigt die Absorption von Wirkstoffen
- Hilft beim Entfernen von Flüssigkeiten und Giftstoffen
- Hilft gegen Verspannungen und erleichtert die Massage
- Beruhigt den Schmerz und die Entzündung

- Idrata in profondità
- Migliora notevolmente l'aspetto della pelle
- Elasticizza la pelle
- Migliora la microcircolazione sanguigna
- Favorisce l'assorbimento dei principi attivi
- Aiuta ad eliminare liquidi e tossine
- Migliora le contratture e facilita il massaggio
- Calma il dolore e l'infiammazione

REF. 04671**Paraffin Monoi aus Tahiti und Minze**

Restaurierende und kräftigende Behandlung der Haut von Händen und Füßen. Monoi-Öl aus Tahiti bringt den natürlichen Wasser-Lipid-Mantel der Haut ins Gleichgewicht. Es macht sie elastischer und sorgt für eine hohe Fähigkeit zur Feuchtigkeitsretention. Kräftigt und erfrischt die Haut dank des Minzöls.

Paraffina monoi di tahiti e menta

Trattamento ricostituente-tonificante per la pelle delle mani e dei piedi. Il Monoi di Tahiti riequilibra lo strato idrolipidico naturale della pelle. Lo rende più elastico e fornisce una Grande capacità di trattenere l'umidità. Grazie all'olio di menta piperita tonifica e rinfresca la pelle.

REF. 04672**Paraffin Orange und Pfirsich**

Nahrhafte und schützende Behandlung der Haut von Händen und Füßen. Reich an Karotin, besitzt hohe antioxidative Eigenschaften. Die ideale Behandlung für reife und dehydrierte Haut.

Paraffina arancia e pesca

Trattamento nutritivo-protettivo per la pelle delle mani e dei piedi. Ricca di caroteni, ha importanti proprietà antiossidanti. È un trattamento ideale per pelli mature e disidratate.

REF. 04673**Paraffin Shea-Butter**

Zur Antioxidationsbehandlung. Shea-Butter ist einer der besten Feuchtigkeitsspender und Aufweichungsmittel par excellence. Sorgt für Wohlbefinden und schützt die Haut.

Paraffina al burro di karité

Trattamento antiossidante. Il Burro di karité è uno degli idratanti ed emollienti per eccellenza. Dona benessere e protezione alla pelle.

**Digitaler Paraffinerwärmer mit Temperaturspeicher****Riscaldatore digitale per paraffina con memoria della temperatura**

u.m.vta: 1

**REF. 06335**

- Leistung: 200 W
- Fassungsvermögen: 2 kg
- Spannung: 220-240 V~
- Frequenz: 50 Hz
- Temperatur: 40°C bis 70°C
- Geeignet für Füße und Hände

- Potenza: 200 W.
- Capacità: 2 Kg
- Voltaggio: 220-240V~
- Frequenza: 50 Hz
- Temperatura: 40°C - 70°C
- Adatto per piedi e mani



Beutel mit 2 Schutzhandschuhen für die Haut gegen UV-Licht und gegen Flecken
Confezione da 2 guanti di protezione per la pelle anti-UV e anti-macchie

u.m.vta: 2	 200
------------	---

REF. 04686



Beutel mit 2 Fausthandschuhen Frottee Paraffin
Confezione da 2 guanti di spugna per paraffina

u.m.vta: 1	 200
------------	---

REF. 06615



Beutel mit 2 Wollsocken Frottee Paraffin
Confezione da 2 pantofole di spugna per paraffina

u.m.vta: 1	 200
------------	---

REF. 06616



Fausthandschuhe aus Frottee für die Behandlung mit Paraffin. Ihr Innenfutter bewahrt die Temperatur für ein optimales Ergebnis der Behandlung.

Guanti di spugna per il trattamento con paraffina. Il loro rivestimento interno permette di mantenere la temperatura per un risultato di trattamento ottimale.

Wollsocken aus Frottee für die Behandlung mit Paraffin. Ihr Innenfutter bewahrt die Temperatur für ein optimales Ergebnis der Behandlung.

Pantofole di spugna per il trattamento con paraffina. Il loro rivestimento interno permette di mantenere la temperatura per un risultato di trattamento ottimale.

Pack 50 Kunststoffbeutel Paraffin
Confezione da 50 sacchetti in plastica per paraffina

u.m.vta: 1	 300
------------	---

REF. 06617

Kunststoffbeutel für die Behandlung von Händen oder Füßen mit Paraffin. Verstärkt die Wärme und verhindert ein rasches Verdampfen.

Sacchetti di plastica per il trattamento con paraffina sia delle mani che dei piedi. Intensificano il calore e ne impediscono che evaporino rapidamente.



Professioneller Nagelfräser 30.000 rpm Tornio professionale da 30.000 giri/min

u.m.vta: 1		8
------------	---	---

REF. 06624



Leistungsstarker Nagelfräser für die professionelle Arbeit. Geräuscharmer Motor und einfache Handhabung für ein komfortables Arbeiten.



- Leistung: 45W
- Spannung: 220 V
- Gewicht Manipel: 157 g
- Motorgundgewicht: 1250 g

Tornio dalle ottime prestazioni per professionisti. Motore silenzioso e impugnatura leggera che permette di lavorare comodamente.

- Potenza: 45W
- Voltaggio: 220 V
- Peso della fresa: 157 g
- Peso base motore: 1250 g



Professioneller Nagelfräser 30.000 rpm Tornio professionale da 30.000 giri/min

u.m.vta: 1		12	
------------	---	----	---

REF. 06625

Nagelfräser mit sensationellem Preis-Leistungs-Verhältnis. Geräuscharm und haltbar, geeignet für Profis und Auszubildende.

- Leistung: 30 W
- Spannung: 110 – 220 V
- Gewicht Manipel: 130 g
- Motorgundgewicht: 730 g

Tornio con un favoloso rapporto qualità/prezzo. Silenzioso e durevole progettato per la professionista e l'apprendista.

- Potenza: 30 W.
- Voltaggio: 110 – 220 V
- Peso della fresa: 130 g
- Peso base motore: 730 g



Umfasst: 6 Accessoires + 6 Schleifpapiere
Include: 6 accessori + 6 mole

Nagelfräser Maniküre POCKET

Tornio per manicure POCKET

Umfasst: 6 Accessoires + 6 Schleifpapiere
Include: 6 accessori + 6 mole

u.m.vta: 1  12

REF. 06695

- Leistungsstark, geräuscharm und tragbar
- Kompaktes Design, ideal für die Reise
- Sehr leicht
- 10 Stunden Betriebsautonomie
- Geschwindigkeit: 30.000 rpm
- Leistung: 24 W
- Stromstärke der Batterie: 2.000 mA (11.1V)
- Ladezeit der Batterie: 2 Stunden
- Betriebsdauer der Batterie bei Höchstgeschwindigkeit: 10 Stunden
- Sehr geräuscharm, erhitzt sich nicht und vibriert nicht
- Gewicht Flacon: 283 g
- Gewicht Manipel: 157 g
- Spannung: 110 – 220 V
- Class II 50/60 Hz



- *Potente, silenzioso e portatile*
- *Design compatto perfetto per i viaggi*
- *Molto leggero*
- *10 ore di autonomia*
- *Velocità: 30.000 RPM*
- *Potenza: 24 W.*
- *Capacità della batteria: 2.000 mA (11.1V)*
- *Tempo di ricarica della batteria: 2 ore*
- *Durata della batteria alla massima velocità: 10 ore*
- *Molto silenzioso, non si riscalda né vibra*
- *Peso della base: 283 g*
- *Peso della fresa: 157 g*
- *Voltaggio: 110 – 220 V*
- *Classe II 50/60 Hz*



Nagelfräser Maniküre QUICK

Tornio per manicure QUICK

Umfasst: 6 Accessoires + 6 Schleifpapiere
Include: 6 accessori + 6 mole

u.m.vta: 1  8 

REF. 06696



- Leistungsstark und geräuscharm
- Kompaktes Design, ideal für die Reise
- Sehr leicht
- Geschwindigkeit: 30.000 rpm
- Leistung: 24 W
- Sehr geräuscharm, erhitzt sich nicht und vibriert nicht
- Gewicht Nagelfräser: 341 g
- Gewicht Manipel: 155 g
- Spannung: 110 – 220 V
- Class II 50/60 Hz.

- *Potente e silenzioso*
- *Design compatto perfetto per i viaggi*
- *Molto leggero*
- *Velocità: 30.000 RPM*
- *Potenza: 24 W.*
- *Molto silenzioso, non si riscalda né vibra*
- *Peso tornio: 341 g*
- *Peso della fresa: 155 g*
- *Voltaggio: 110 – 220 V*
- *Classe II 50/60 Hz*



Ersatzteile für Nagelfräser

Ricambi per torni

u.m.vta: 1	 12	
------------	--	---

- REF. 06779**
- Bohrfutter-Adapter für Schleifzylinder
 - Mandrino adattatore per smerigliatori

- REF. 06780**
- Polierbürste
 - Ø 0,65
 - Scovolino per lucidare
 - Ø 0,65

- REF. 06781**
- Steinkegel Filz
 - Ø 0,6
 - Cono in pietra con feltro
 - Ø 0,6



- REF. 06782**
- Steinfräser in Fassform
 - Ø 0,6
 - Fresa in pietra con forma a botte
 - Ø 0,6

- REF. 06783**
- Steinfräser konisch
 - Ø 0,4
 - Fresa in pietra conica
 - Ø 0,4

- REF. 06784**
- Diamantfräser mit runder Spitze
 - Fresa diamantata punta tonda



- REF. 06785**
- Steinfräser in Fassform
 - Fresa diamantata forma cilindrica

- REF. 06786**
- Diamantfräser zylindrische Fassform
 - Fresa diamantata forma cilindrica a botte

- REF. 06787**
- Diamantfräser zylindrische Fassform
 - Fresa diamantata forma cilindrica a botte



Ersatzteile für Nagelfräsern**Ricambi per torni**

u.m.vta: 1

12

**REF. 06788**

- Diamantfräser zylindrische
- Fresa diamantata forma cilindrica a botte

REF. 06789

- Keramikfräser Fassform Durchmesser
- Fresa ad ago diamantato

REF. 06790

- Diamantfräser Nadel
- Fresa lucidante in silicene

**REF. 06791**

- Keramikfräser Fassform mit runder Spitze
- Ø 0,66
- Fresa in ceramica a botte diametro
- Ø 0,66

REF. 06792

- Silikon-Fräser zum Polieren Korn
- Ø 0,66
- Fresa in ceramic
- a a botte punta tonda
- Ø 0,66

REF. 06793

- Keramikfräser Nadelform Durchmesser
- Ø 0,23
- Fresa in ceramica ad ago diametro
- Ø 0,23

**REF. 06794**

- Keramikfräser konisch
- Ø 0,6
- Fresa in ceramica conica diametro
- Ø 0,6

REF. 06795

- Wolframfräser blau konisch
- Ø 0,6
- Fresa conica in tungsteno blu
- Ø 0,6



Kit Accessoires Kit accessori

6 Accessoires + 6 Schleifpapiere
6 accessori + 6 mole

u.m.vta: 1  500

REF. 06626



Dispenser 100 Schleifzylinder Dispenser 100 cilindri smerigliatori

u.m.vta: 1  30

REF. 06627

- Fein
- Härte: 180
- Fini
- Durezza: 180

REF. 06628

- Mittel
- Härte: 120
- Medi
- Durezza: 120

REF. 06629

- Gob
- Härte: 80
- Spessi
- Durezza: 80



Nagelfräser PROMED 620

Tornio PROMED 620

u.m.vta: 1  6

REF. 04103



- Leistung: 21W
- Bidirektionaler Nagelfräser mit 10 Accessoires und 30 Schleifpapieren
- Der kleinste professionelle Tisch-Nagelfräser auf dem Markt
- Geeignet für die Behandlung von Finger- und Zehennägeln sowie von falschen Fingernägeln, mit Gel oder Acryl
- Beseitigt problemlos Schwielen und Verhärtungen
- Reduzierte Größe: 11 x 9 x 8 cm
- Resistent gegen Azeton mit Motorkühlung (75g)
- Auflagerstütze Nagelfräser, in der Basis integriert
- Enthält verschiedene Fräsen und Zwingen (10 Accessoires + 30 Schleifpapiere)
- Automatischer Schnellverschluss für Standard-Fräsen oder Zwingen von 2,25 mm
- Schalter mit Staubschutz
- Drehzahl stufenlos einstellbar bis 20.000 rpm
- Spannung: 115-230 V~
- Frequenz 50/60 Hz

- Potenza: 21W.
- Tornio a doppio senso di rotazione con 10 accessori e 30 mole
- Il più piccolo tornio professionale da banco sul mercato
- Adatto per il trattamento delle unghie di piedi e mani, unghie finte in gel o acriliche
- Rimuove facilmente calli e duri
- Dimensioni ridotte: 11 x 9 x 8 cm
- Resistente all'acetone con motore raffreddato (75g)
- Staffa di appoggio del tornio integrata nella base
- Include diverse frese e punte (10 accessori + 30 mole)
- Sgancio rapido automatico per frese o punte standard da 2,25 mm
- Interruttore con protezione antipolvere
- Giri regolabili senza interruzioni fino a 20.000 rpm
- Voltaggio: 115-230V~
- Frequenza 50/60 Hz

Nagelfräser PROMED PERFECT

Tornio PROMED PERFECT

u.m.vta: 1  12

REF. 03222

- Leistung: 21 W
- 12.000 rpm
- Bidirektional
- 10 Accessoires + 30 Schleifpapiere + 1 Bürste
- Eingebautes Kaltlicht zur Beleuchtung des Arbeitsbereichs
- Spannung: 220-220 V~
- Frequenz 50 Hz

- Potenza: 21 W.
- 12.000 RPM
- Doppio senso
- 10 accessori + 30 mole + 1 scovolino
- Luce fredda incorporata per illuminare l'area di lavoro
- Voltaggio: 220-230V~
- Frequenza 50 Hz



Gerät für maniküre & pediküre MP815

Tornio MP815 manicure/pedicure

u.m.vta: 1  4

REF. 06443

Pflege und Behandlung von Nägeln, Nagel- und Hornhaut. Mit LED-Leuchte für eine präzisere Anwendung, für Diabetiker geeignet.

- Dazugehörige Accessoires für Nagelpolitur: 2 Polierrollen und 2 Glättrollen
- Mit 7 hochwertigen Zubehörteilen für unterschiedliche Anwendungen
- Drehrichtung nach rechts und links, ergonomisches Design
- Stoppt automatisch, wenn zu hoher Druck ausgeübt wird
- Maße: 15 x 3,8 x 3,7 cm
- Gewicht: 101 g
- Spannung: 230V, 50 hz
- Drehgeschwindigkeit: 3 Stufen von 3.500 / 5.000 / 8.000 U/min
- Kabellänge: 1,5 m
- Mit Aufbewahrungstasche

Per la cura e il trattamento di unghie, cuticole e duroni. Con luce led per un'applicazione più precisa e adatto per diabetici.

- Accessori per la lucidatura delle unghie inclusi: 2 rulli leviganti e 2 rulli lucidanti
- 7 accessori di alta qualità per diverse applicazioni
- Rotazione verso destra e verso sinistra, design ergonomico
- Si ferma automaticamente quando la pressione è troppo alta
- Dimensioni: 15 x 3,8 x 3,7 cm
- Peso: 101 g
- Tensione: 230V, 50hz
- Velocità di rotazione: 3 livelli di velocità: 3.500 / 5.000 / 8.000 rpm
- Lunghezza del cavo: 1,5 m
- Con custodia



Gerät für maniküre & pediküre MP815

Tornio MP815 manicure/pedicure

u.m.vta: 1  4

REF. 06444

Pflege und Behandlung von Nägeln, Nagel- und Hornhaut. Gerät mit 7 hochwertigen Zubehörteilen für unterschiedliche Anwendungen. Für Diabetiker geeignet.

- Drehrichtung nach rechts und links, ergonomisches Design
- Stoppt automatisch, wenn zu hoher Druck ausgeübt wird
- Maße: 15 x 3,8 x 3,7 cm
- Gewicht: 101 g
- Spannung: 230V, 50 HZ
- Drehgeschwindigkeit: 2 Stufen von 3.500 / 4.600 U/min
- Kabellänge: 1,5 m
- Mit Aufbewahrungstasche

Per la cura e il trattamento di unghie, cuticole e duroni. Tornio 7 accessori di alta qualità per diverse applicazioni. Adatto per diabetici.

- Rotazione verso destra e verso sinistra, design ergonomico
- Si ferma automaticamente quando la pressione è troppo alta
- Dimensioni: 15 x 3,8 x 3,7 cm
- Peso: 101 g
- Tensione: 230V, 50hz
- Velocità di rotazione: 2 livelli di velocità: 3.500 / 4.600 rpm
- Lunghezza del cavo: 1,5 m
- Con custodia



Ersatzteile für Nagelfräser

Ricambi per torni

u.m.vta: 1  10

REF. 06443



REF. 06444

REF. 02149



- Filzkegel
- Cono in feltro

REF. 02150



- Saphirkegel feinkörnig
- Cono in zaffiro a gana fine

REF. 02151



- Saphirkegel gobkörnig
- Cono in zaffiro a gana gossa

REF. 02152



- Saphirscheibe feinkörnig
- Disco in zaffiro a gana fine

REF. 02153



- Saphirfräser
- Fresa in zaffiro

REF. 02154



- Nadelschneider
- Taglia aghi

REF. 02155



- Saphirkegel goß
- Cono in zaffiro Grande

REF. 02156



- Hautschieber
- Spingi pellicine

REF. 02157



- Zylinderschneider
- Taglierino cilindrico

REF. 02158



- Saphirscheibe gobkörnig
- Disco in zaffiro a gana gossa

REF. 02159



- Saphirschneider oval
- Taglierino ovale in zaffiro

REF. 02164



- Besen
- Scovolino

REF. 02165



- Fräser-Adapter
- Adattatore per frese

REF. 02160



- Adapter mit 30 Tuben Schleifpapier
- Adattatore con 30 tubetti smerigliatura

Ersatzteile für Nagelfräser

Ricambi per torni

u.m.vta: 1  10

REF. 04103



REF. 03222

REF. 02958

- Schleifer konisch Saphir
- Smerigliatore conico in zaffiro



★

REF. 02959

- Fräser spitz Saphir
- Smerigliatore conico in zaffiro



★

REF. 02960

- Fräser rund Saphir
- Fresa smussata in zaffiro



★

REF. 02961

- Fräser rund Saphir, feinkörnig
- Disco lima in zaffiro, a grana fine



★

REF. 02962

- Schleifkegel/Filter
- Cono levigante/filtro



★

REF. 02976

- Adapter Schleifzylinder
- Adattatore cilindrico smerigliatura



★

REF. 02980

- Adapter Schleifzylinder
- Lucidante silicone medio



★

REF. 02981

- Adapter Schleifzylinder
- Lucidante silicone spesso



★

REF. 02982

- Fräser lang
- Fresa lunga



★

REF. 02983

- Schleifer Pediküre
- Schwielen
- Smerigliatore per pedicure



★

*Nicht sterilisierbar, weder mit Druck noch mit Temperatur (selbstreinigend, Quarzsterilisator). Nur mit Desinfektionsmittel oder Alkohol desinfizieren

Non sterilizzabile a pressione o temperatura (autopulente, sterilizzatore al quarzo).
Disinfettabile solo con disinfettante o alcool

Saphirscheibe mittlere Körnung

Disco in zaffiro a grana media

u.m.vta: 1  12 

REF. 07237

- Für Drehmaschine für Maniküre-Pediküre
- Per tornio manicure-pedicure



Lupe mit Licht

Lente d'inGrandimento con luce

u.m.vta: 1  4

REF. 03821



- Leistung: 5W
- Linse 5 Dioptrien
- Durchmesser Linse: 10,16 cm
- Beleuchtung: 48 LEDs
- Schutzabdeckung für Linse, Sockel für Lupenleuchte mit Gewicht zur Verwendung auf dem Tisch
- Spannung: 220-240 V~
- Frequenz 5 Hz
- Potenza: 5W.
- Lente da 5 diottrie
- Diametro lente: 10,16 cm
- Illuminazione: 48 led
- Copriobiettivo protettivo, base da tavolo
- Voltaggio: 220-240V~
- Frequenza 5 Hz

Lupe mit LED-Lampe

Lente d'inGrandimento con luce a led

u.m.vta: 1  4



REF. 04948



- Leistung: 5W
- Linse 5 Dioptrien
- 60 SMD-LEDs mit 6 Abstufungsniveaus im Kalt- und Warmmodus
- 800 Lumen
- Maximales Licht, mit sehr echter Farbwiedergabe,
- Lange Lebensdauer und sehr niedriger Verbrauch
- Der Farbwiedergebeindex beträgt 80%, wodurch die Farben treu wiedergegeben werden
- Erzeugt keine Wärme
- Durchmesser Lupenglas 12,7 cm
- Glasdicke 0,5 bis 2,1 cm
- 100-240 V AC 50-60 Hz
- Potenza: 5W.
- Lente da 5 diottrie
- 60 led Smd, 6 livelli di graduazione in modalità freddo e caldo
- 800 lumen
- Massima luce, con una riproduzione dei colori molto reale,
- lunga durata e bassissimi consumi
- Indice di resa cromatica dell'80% che riproduce fedelmente i colori
- Non genera calore
- Diametro della lente 12,7 cm
- Spessore del cristallo da 0,5 a 2,1 cm
- 100-240V AC 50-60hz

Lupe mit Licht

Lente d'inGrandimento con luce

u.m.vta: 1  10 

REF. 04624

- Tischlampe Maniküre mit Fuß und Klemme
- Linse 5 Dioptrien
- Größe Linse: 100 mm
- Beleuchtung: 30 LED SMD
- Spannung: 100-240 V
- Frequenz: 50/60 Hz
- Maximale Leistung: 6 W
- Arm Typ Schwanenhals für Lupenständer
- Rutschfester Clip für Tisch mitgeliefert
- Verwendung in Innenräumen
- 560 Lumen für den professionellen Gebrauch

REF. 04947

- Lampada da tavolo per manicure con piede e morsetto
- Lente da 5 diottrie
- Dimensione della lente: 100 mm
- Illuminazione: 30 led smd
- Voltaggio: 100-240V
- Frequenza: 50/60 Hz
- Potenza massima: 6W.
- Braccio direzionabile per porta lente d'inGrandimento
- Clip antiscivolo da tavolo inclusa
- Uso interno
- 560 lumen per uso professionale



Mit Extrazubehör zur Befestigung am Tisch
Con accessorio extra per l'aggancio al tavolo

Lupe mit Licht led

Lente d'inGrandimento con luce led

u.m.vta: 1  4

3 Dioptrien
3 diottrie

REF. 03815



5 Dioptrien
5 diottrie

REF. 03816

- Leistung: 22W
- Größe der Linse: 12,7 cm
- Schutzabdeckung für Linse
- Schwenkbarer Arm für Lupenständer
- Schraubzwinde für Tisch mitgeliefert

8 Dioptrien
8 diottrie

REF. 03817

- Potenza: 22W.
- Dimensione della lente: 12,7 cm
- Coprilente protettivo
- Braccio direzionabile per porta lente d'inGrandimento
- Morsetto per il tavolo incluso

Lupe LED SMD

Lente d'inGrandimento LED SMD

u.m.vta: 1  1

3 Dioptrien
3 diottrie

REF. 04107

5 Dioptrien
5 diottrie

REF. 04108

8 Dioptrien
8 diottrie

REF. 04109

- Leistung: 22W
- Größe der Linse: 12,7 cm
- 60 LEDS SMD UND 570 LUMEN
- Maximales Licht, mit sehr echter Farbwiedergabe, langer Lebensdauer und sehr niedrigem Verbrauch 6W
- Erzeugen keine Wärme
- 8 Dioptrien

- Potenza: 22W.
- Dimensione della lente: 12,7 cm
- 60 LED SMD E 570 LUMEN
- Massima luce, con riproduzione dei colori molto reale, lunga durata e bassissimo consumo 6W
- Non genera calore
- 8 diottrie



Pies lupa

Basi per lenti d'inGrandimento

REF. 03820



REF. 03819





REF. 04110



* Anpassbar an Ref.-Nr. 03815, 03816, 03817, 04107, 04108, 04109 und 04198
* Adattabile ai riferimenti 03815, 03816, 03817, 04107, 04108, 04109 e 04198

Nagelfeilen einzelner Beutel: gerade

Lime sacchetto singolo: dritta

u.m.vta: 12  192 

Gewicht: 10 g.
Peso: 10 g.

Dicke: 0,6 cm
Spessore: 0,6 cm

80/100

150/180

REF.06697

REF.06698

100/180

180/240

REF.06010



REF.06699



Nagelfeilen einzelner Beutel: gebogen

Lime sacchetto singolo: curva

Dicke: 0,6 cm
Spessore: 0,6 cm

u.m.vta: 12  192 

80/100

150/180

REF.06700

REF.06701

100/180

180/240

REF.06011



REF.06702



Nagelfeilen einzelner Beutel: Halbmond
Lime sacchetto singolo: mezza luna

Dicke: 0,6 cm
 Spessore: 0,6 cm

Gewicht: 10 g.
 Peso: 10 g.

u.m.vta: 12  192 

80/100

REF.06703

150/180

REF.06704

100/180

REF.06012

180/240

REF.06705



Nagelfeilen einzelner Beutel: Rocket
Lime sacchetto singolo: Rombo

Dicke: 0,6 cm
 Spessore: 0,6 cm

u.m.vta: 12  192 

100/180

REF.06013



Nagelfeilen einzelner Beutel: quadratisch
Lime sacchetto singolo: quadrata

Dicke: 0,6 cm
 Spessore: 0,6 cm



u.m.vta: 12  192 

100/180

REF.06014



Giff aus metall für feile
Manico in metallo per lima

u.m.vta: 1  12 



REF.07222 **Gerade**
Dritta

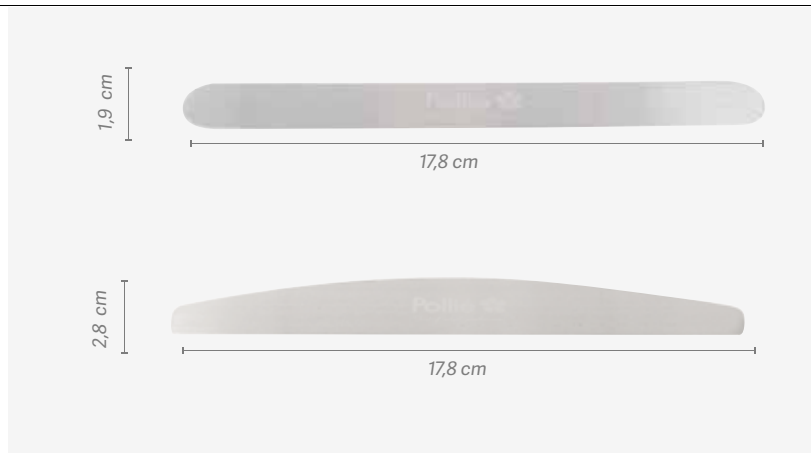

REF.07223 **Halbmond**
Mezza luna



Pack 48 ersatzteile feile schwarz
Confezione da 48 ricambi lima nera



u.m.vta: 1  12 

Gerade **Halbmond**
Dritta **Mezza luna**

REF.07224 **REF.07225**



Pack 48 ersatzteile feile Weiß
Confezione da 48 ricambi lima Bianca

u.m.vta: 1  12 

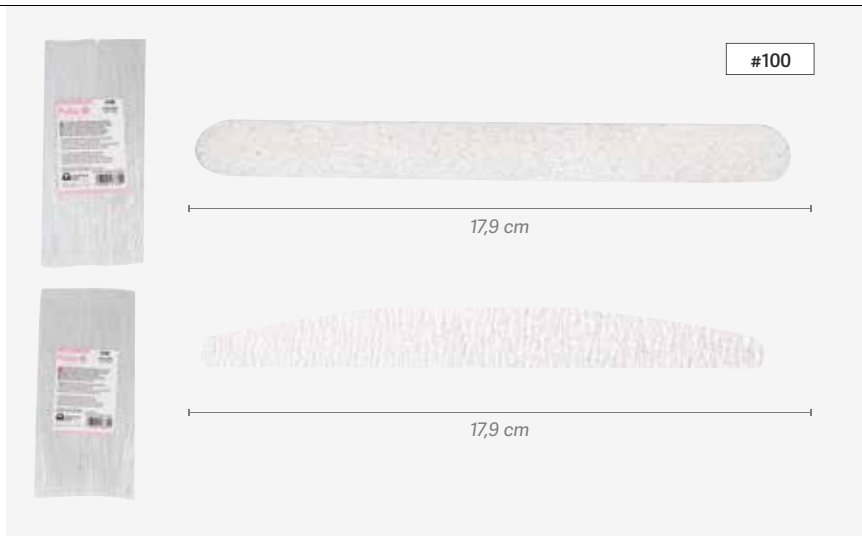

Gerade **Halbmond**
Dritta **Mezza luna**

REF.07228 **REF.07229**



Pack 48 ersatzteile feile zebra

Confezione da 48 ricambi lima zebra

u.m.vta: 1  12 

Gerade
Dritta

REF.07226



Halbmond
Mezza luna

REF.07227



Nagelfeilen in Pack von 12 STÜCK

Lime in confezione da 12 UNITÀ

u.m.vta: 1  40 

80/80

REF.06020

100/100

REF.06021

180/180

REF.06022

240/240

REF.06023

400/400

REF.06024

600/600

REF.06025





Gerade
Dritta

Wählen Sie das Papiergewicht, was Ihnen am besten passt
Scegli la gammatura più adatta a te

Nagelfeilen in Pack von 12 STÜCK

Lime in confezione da 12 UNITÀ



u.m.vta: 1	 40	
------------	--	---

REF.06000

Gerade
Dritta

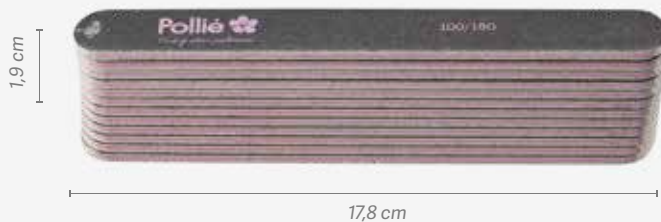
100/180





u.m.vta: 1	 40	
------------	--	---

REF.06001

Gebogen
Curva





u.m.vta: 1	 32	
------------	--	---

REF.06002

Halbmond
Mezza luna





u.m.vta: 1	 28	
------------	--	---

REF.06003

Rocket
Rombo



u.m.vta: 1	 32	
------------	--	---



REF.06004

Quadratisch
Quadrata



Nagelfeilen einzelner Beutel zebra

Lime sacchetto singolo zebra

u.m.vta: 12  192 

REF.06015 **Gerade**
Dritta



REF.06016 **Gebogen**
Curva



REF.06017 **Halbmond**
Mezza luna



REF.06018 **Rocket**
Rombo





REF.06019 **Quadratisch**
Quadrata



Nagelfeilen in pack von 12 Stück zebra
Lime in confezione da 12 unità zebra

Dicke: 0,6 cm
 Spessore: 0,6 cm

u.m.vta: 1  40 



REF.06005 **Gerade**
Dritta

1,9 cm



17,8 cm

100/180



u.m.vta: 1  40 

REF.06006 **Gebogen**
Curva

1,9 cm



17,8 cm



u.m.vta: 1  32 

REF.06007 **Halbmond**
Mezza luna

2,8 cm



17,8 cm



u.m.vta: 1  28 

REF.06008 **Rocket**
Rombo

3,1 cm



17,8 cm

u.m.vta: 1  32 

REF.06009 **Quadratisch**
Quadrata

2,8 cm



17,8 cm



Professionelle Nagelfeile schwarz gepolstert
Lima professionale nera imbottita

Dicke: 0,3 cm
 Spessore: 0,3 cm

u.m.vta: 12 300

100/180

REF.03427 **Gerade**
Dritta



REF.03428 **Gebogen**
Curva



u.m.vta: 12 384

REF.03429 **Quadratisch**
Quadrata



Professionelle Nagelfeile Zebromuster gepolstert 12 STÜCK
Lima professionale zebra imbottita 12 UNITÀ

Dicke: 0,3 cm
 Spessore: 0,3 cm

u.m.vta: 12 480

REF.03425 **Gerade**
Straight



u.m.vta: 12 300

REF.03424 **Gebogen**
Curva



u.m.vta: 12 300

REF.03426 **Quadratisch**
Quadrata



100/180. Waschbar und desinfizierbar. Komplettes und professionelles Schleifsystem. Extra Haltbarkeit. Doppelt so schnell wie normale Nagelfeilen. Hervorragend für Fingernägel mit Gel und Acryl

100/180. Lavabili e disinfettabili. Sistema abrasivo completo e professionale. Durata extra. Lima 2 volte più veloce delle lime normali. Eccellente per unghie in gel e acriliche

Pack 12 Nagelfeilen super gepolstert
Confezione da 12 lime super imbottite

Dicke: 0,8 cm
 Spessi ness: 0,8 cm

u.m.vta: 1 25

Zebra

REF.06358 **REF.06360** **Gerade Dritta**

100/180

Zebra

REF.06359 **REF.06361** **Gebogen Curva**

100/180

Packung mit 50 Nagelfeilen amerikanisch. Professionelle Verwendung
Confezione da 50 lime americano. Uso professionale

Dicke: 0,13 cm
 Spessore: 0,13 cm

u.m.vta: 1 40

- Komplettes und professionelles Schleifsystem
- Extra Haltbarkeit
- Dicke: 0,13 cm
- Doppelt so schnell wie konventionelle Nagelfeilen
- Hervorragend für Fingernägel mit Gel und Acryl

- Sistema abrasivo completo e professionale.
- Durata extra.
- Lima 2 volte più veloce delle lime convenzionali.
- Eccellente per unghie in gel e acriliche

Weiß Bianco

REF.06812 **REF.06813**

Nagelfeile schwarz doppelseitig
 Lima nera 2 lati

Nagelfeile weiß doppelseitig
 Lima bianca 2 lati

100/180



Amerikanische Nagelfeilen schwarz

Confezione lime americane nere

Dicke: 0,13 cm
Spessore: 0,13 cm

u.m.vta: 10  1500



REF.01027



Pack 12 Nagelfeilen gepolstert schwarz

Confezione da 12 lime imbottite nere

Dicke: 0,3 cm
Spessore: 0,3 cm

u.m.vta: 1  40 

REF.01030



REF.01421

Nagelfeilen einzelner Beutel

Lime sacchetto singolo

Dicke: 0,4 cm
Spessore: 0,4 cm

u.m.vta: 12  600



REF.01200



Pack 12 professionelle Nagelfeilen Zebromuster super gepolstert

Confezione da 12 lime professionali super imbottite

Dicke: 0,3 cm
Spessore: 0,3 cm

u.m.vta: 1  40 

REF.03731

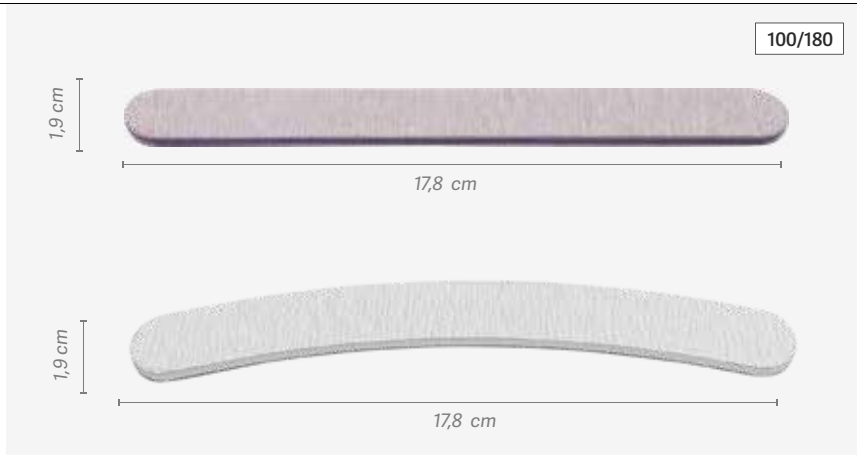

REF.03730

Beutel 10 Nagelfeilen aus Pappe Confezione da 10 lime in cartone

Dicke: 0,12 cm
Spessi ness: 0,12 cm

u.m.vta: 12  336

REF.00601

- Klein
- Piccolo



u.m.vta: 12  204

REF.00602

- Groß
- Grande



Beutel 6 Nagelfeilen aus Pappe Confezione da 6 lime in cartone

u.m.vta: 12  756

REF.01107

Dicke: 0,3 cm
Spessore: 0,3 cm



Satz 20 Nagelfeilen Ref.-Nr. 601-602 (10 + 10) Set da 20 lime r.601-602 (10 + 10)

Dicke: 0,1 cm
Spessore: 0,1 cm

u.m.vta: 12  120

REF.00621

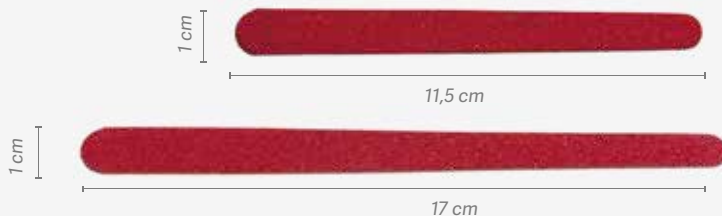

Beutel 5 Stück amerikanische Nagelfeilen rot Confezione da 5 lime americane rosse

Dicke: 0,12 cm
Spessore: 0,12 cm

u.m.vta: 12  216

REF.01517

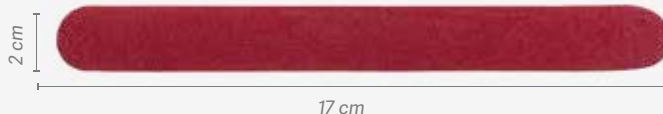

Packung 10 Nagelfeilen, lose Confezione da 10 lime, sfuse

Dicke: 0,12 cm
Spessore: 0,12 cm

u.m.vta: 12  336



REF.01116

- Klein
- Piccolo



Beutel 5 Nagelfeilen verschiedene Farben
Confezione da 5 lime colori vari

Dicke: 0,6 cm
 Spessore: 0,6 cm

u.m.vta: 12  60 



180

REF.06367

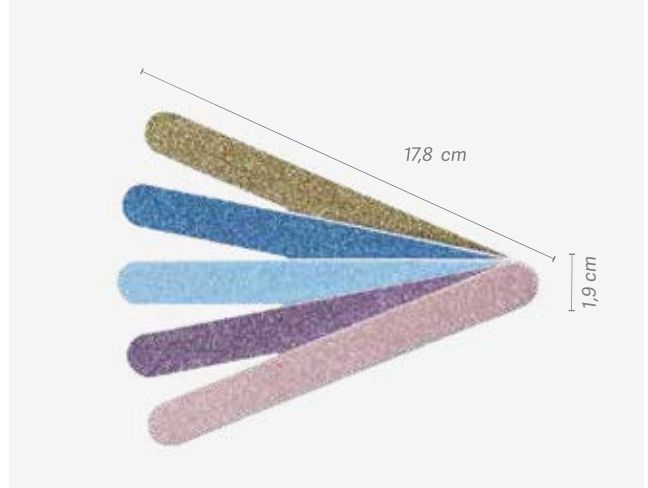
- Eine Seite Glitter, die andere Papiergewicht 180
- Un lato glitter, l'altro con grammatura 180



Beutel 5 Nagelfeilen bedruckt
Confezione da 5 lime fantasia



u.m.vta: 12  60 

180/240

REF.06365

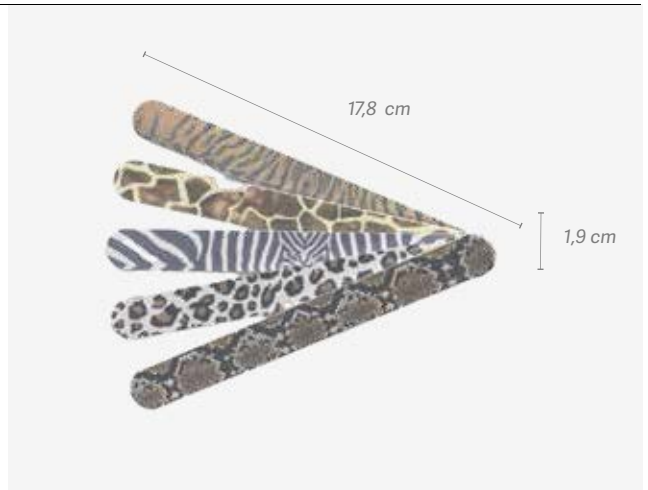
- Tieraufdrucke
- Fantasia animale



u.m.vta: 12  60 

180/240

REF.06366

- Verschiedene Aufdrucke
- Fantasia varie

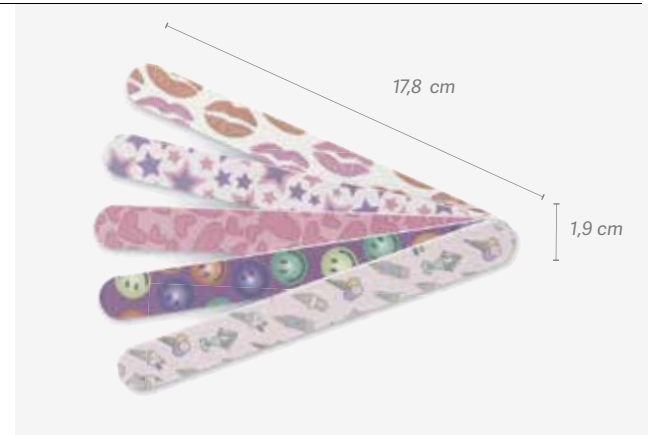

Dicke: 0,6 cm
 Spessore: 0,6 cm



**Perfekte Maniküre,
 FARBIG**

**Manicure perfetta
 CON COLORE**

Verkaufsträger für 42 Nagelfeilen Espositore da 42 lime

u.m.vta: 1  20 



180

REF.06416

- 6 Modelle x 7 Stück.
- Eine Seite Glitter, die Nagelfeile mit Papiergewicht 180
- Verschiedene Farben
- 6 modelli x 7 unità.
- Un lato glitter, l'altro con gammatura 180
- Colori assortiti



Verkaufsträger für 48 Nagelfeilen Espositore da 48 lime

u.m.vta: 1  20 



180/240

REF.06415

- 6 Modelle x 8 Stück
- Tieraufdrucke
- 6 modelli x 8 unità
- Fantasia animale



Verkaufsträger für 48 Nagelfeilen bedruckt Espositore da 48 lime fantasia

u.m.vta: 1  20 

180/240

REF.06414

- 6 Modelle x 8 Stück
- Verschiedene Aufdrucke
- 6 modelli x 8 unità
- Fantasia varie



Nagelfeile zum Polieren Helligkeit Lima per lucidatura luminosità

Dicke: 0,3 cm
Spessore: 0,3 cm

u.m.vta: 12  360



REF.01029

- 4 Verwendungen
- 4 servizi



3-seitige Pufferdateien File buffer a 3 lati

3 Verwendungen
3 servizi

u.m.vta: 12  240 

REF.06363



Gewichte:

- Rosa Teil: 320
- Weißer Teil: 600
- Gauer Teil: 4000

Pesi:

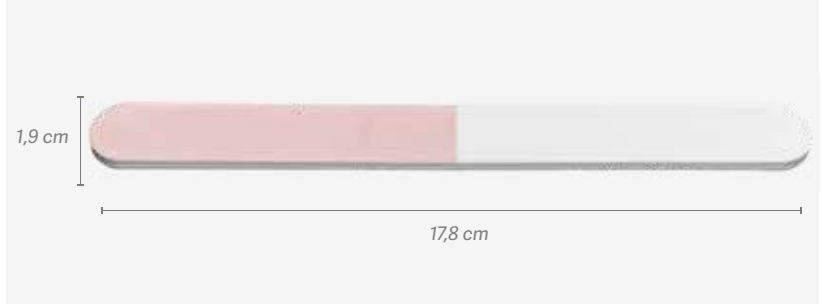
- Parte rosa: 320
- Parte bianca: 600
- Parte grigia: 4000



u.m.vta: 12  84 

REF.06362

Gewichte:



- Rosa Teil: 320
- Weißer Teil: 600
- Gauer Teil: 4000

Pesi:

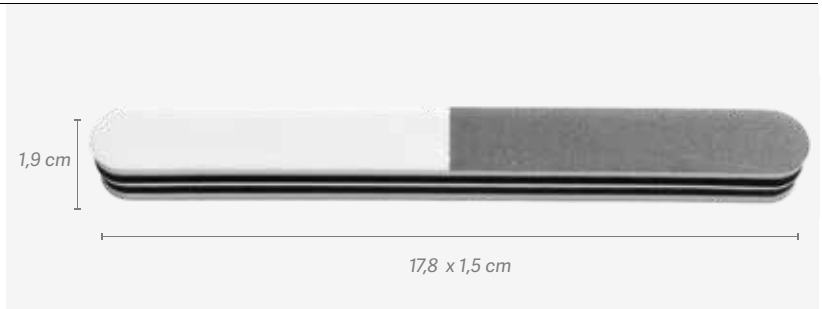
- Parte rosa: 320
- Parte bianca: 600
- Parte grigia: 4000



Nagelfeile rot zum Polieren, Halbmond mit Beutel Lima rosa per lucidatura a mezzaluna con sacchetto



u.m.vta: 12  60 

REF.06706

100/180



Nagelfeile rot zum Polieren, mit Beutel Lima rossa per lucidatura con sacchetto

u.m.vta: 12  144 

REF.06712

80/80





Nagelfeile rechteckig zum Polieren
Lima rettangolare per lucidatura

u.m.vta: 12  120

REF.01380



Nagelfeile Block 4 Seiten
Lima a mattoncino a 4 lati



u.m.vta: 12  216 

240/320/400/4000

REF.06029



20 Nagelfeilen Block 3 Seiten
20 lime a mattoncino a 3 lati

u.m.vta: 1  46 

- Lila
- Viola

- Orange
- Arancioni



80/80/100

100/100/180

REF.06030

REF.06031





u.m.vta: 1  56 

120

REF.06032

- Weiß
- Bianco



u.m.vta: 12  216 

120

REF.06028

- Weiß
- Bianco

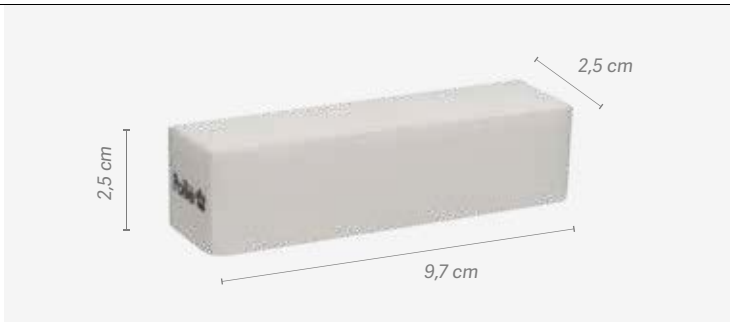

Box mit 50 Polierblöcken mini Block Confezione da 50 mini mattoncini

u.m.vta: 1

120



120/120

REF.06708

Der zweiseitige Polierblock mit Granulation von 120 ist die ideale Nagelfeile zum Nivellieren von großen Oberflächen, auf natürlichen oder falschen Fingernägeln.

Il mattone lucidante bilaterale con la sua grana da 120 è la lima ideale per uniformare Grandi superfici, sia su unghie naturali che su unghie finte.

- 2 Seiten
- Farbe weiß
- 2 lati
- Colore bianco



Beutel mit 6 Polierblöcken mini Block Confezione da 6 mini mattoncini

u.m.vta: 12

192



120/120

REF.06707

- 2 Seiten
- Farbe weiß
- 2 lati
- Colore bianco



Nagelfeilen Glas Lime in cristallo

u.m.vta: 1

12

Lila
ViolaRosa
Rosa

REF.06630/68

REF.06630/70

- 2 Seiten
- 2 lati

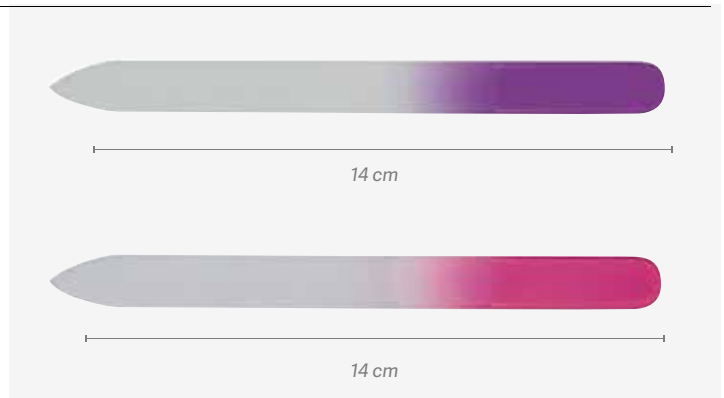

Nagelfeile Saphire mit Griff Lime Saphire con manico

u.m.vta: 12  300

REF.00841

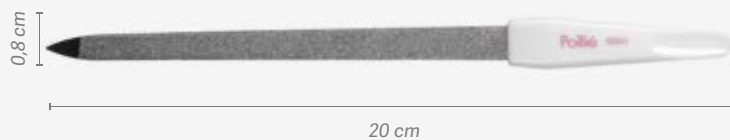

REF.00842



REF.00843



REF.00844



REF.00845



Handauflagekissen weiß Cuscino poggiamani bianco

u.m.vta: 1  50

REF.04969

- Für eine komfortablere Maniküre, sowohl für den Kunden als auch für den Kosmetiker
- Per rendere la manicure più confortevole sia per la cliente che per l'estetista



Sterilisator trockene Wärme Sanity Security Sterilizzatore a calore secco Sanity Security

u.m.vta: 1  1

REF. 03011

- Leistung: 400 W
- 230° C
- Spannung: 220-240 V~
- Frequenz 50 Hz
- Einstellbare Temperatur von 20 bis 200°

- Potenza: 400W.
- 230° C
- Voltaggio: 220-240V~
- Frequenza 50 Hz
- Temperatura regolabile da 20 a 200°



Sterilisator keimtötend GX4 Sterilizzatore germicida GX4

u.m.vta: 1  1

REF. 03009/59

- Leistung: 15W
- Ultra flach
- Keimtötendes Licht erste Qualität

- Potenza: 15W.
- Ultra piatto.
- Luce germicida di alta qualità

u.m.vta: 1  20

REF. RE00891/01



Ersatz-UV-Lampe
Ricambio lampadina UV

Sterilisator GX7 Orange Sterilizzatore GX7 arancione

u.m.vta: 1  1

REF. 03010/64

- Leistung: 75W
- Fassungsvermögen 120 ccm
- Mit Quarzkugeln
- Spannung: 220-240 V~
- Frequenz 50 Hz

- Potenza: 75W.
- Capacità 120 cc
- Con sfere di quarzo
- Voltaggio: 220-240V~
- Frequenza 50 Hz





Ersatzteile Ricambi

- Beutel Ersatz-Quarzkugeln
- 50/60 Bälle pro Beutel
- Gewicht 160g ca

- Ricambio sfere di quarzo
- 50/60 palline per sacchetto
- peso 160 g ca

REF. RE03010/64/01

Sterilisator EUROSTIL Sterilizzatore EUROSTIL



u.m.vta: 1  6 

REF. 07013

- Mit Quarz
- Ideal für Utensilien, Scheren
- Enthält eine Tüte Kugeln
- Nicht geeignet für Kunststoffmaterialien

- Quarzo
- Ideale per utensili, forbici
- Include un sacchetto di sfere
- Non adatto per materiali plastici

Dose Quarkugeln Contenitore di sfere di quarzo

u.m.vta: 1  12 

500 g



REF. 06619

Zur Sterilisation von
Metallwerkzeugen für Friseur-
und Schönheitssalons

*Per sterilizzare strumenti in
metallo sia per parrucchieri che
per estetisti*



Sterilisator UV Eurostil Kunststoff Sterilizzatore UV Eurostil in plastica

u.m.vta: 1  1 

REF. 06618

Sterilisator mit UV-Strahlen für alle
Art von Werkzeugen für Friseur- und
Schönheitssalons

- Leistung 8 W

*Sterilizzatore ultravioletto per tutti i tipi
di strumenti, sia per parrucchieri che per
estetisti*

- Potenza 8W.





u.m.vta: 1  1

REF. RE06618/01



Nagelhautzange Tagliacuticole

u.m.vta: 1  10 

Federanschlag Gifffläche 5,5 mm
Apertura della presa 5,5 mm

REF. 04659



Die Produktpalette PREMIUM von Pollié ist dafür gedacht, Ihre Erfordernisse maximal zu befriedigen. Hergestellt aus Edelstahl. Pollié Premium bietet die beste Qualität und Leistung mit den neuen Zangen für Fingernägel und Nagelhaut. Die letzten Produktionsschritte erfolgen von Hand, um die perfekte Zange zu erhalten.

La gamma di prodotti PREMIUM di Pollié è pensata e prodotta per soddisfare pienamente le tue esigenze. Realizzati in acciaio inossidabile. Pollié Premium offre la migliore qualità e le migliori prestazioni con le sue nuove pinze per unghie e cuticole, gli ultimi passaggi della loro fabbricazione sono fatti a mano per ottenere una pinza perfetta.

Federanschlag Gifffläche 4,5 mm
Apertura della presa 4,5 mm

REF. 04660





Federanschlag Gifffläche 5,5 mm
Apertura della presa 5,5 mm

REF. 04661



Nagelknipser Tagliaunghie

u.m.vta: 1  50 

Einfacher Anschlag
Presca semplice

REF. 04663



Nagelhautzange titanblau
Tagliacuticole blu titanio

u.m.vta: 1  12

REF.03243



10 cm

REF.03244



10 cm

REF.04697



11 cm

REF.03245



12 cm

Nagelhautzange
Tagliacuticole

u.m.vta: 1  12

Mit Verschluss
 Con sicura

REF.01275



11 cm

Nagelhautzange
Tagliacuticole

u.m.vta: 1  12

Eingerastet
Incastro

REF.02125



8 cm

Gifffläche 5 mm
Apertura 5 mm

REF.04692



10 cm

REF.01272



10 cm

REF.03688



11 cm

Nagelhautzangen Tagliacuticole

u.m.vta: 1  1

Kohlenstoffstahl
Acciaio al carbonio

REF.02264

Ersatzfeder +
Schraube für Zange
Molla di ricambio +
vite pinza

REF.02404

Extrafein
Edelstahl
Superfine
Acciaio
inossidabile

REF.02679

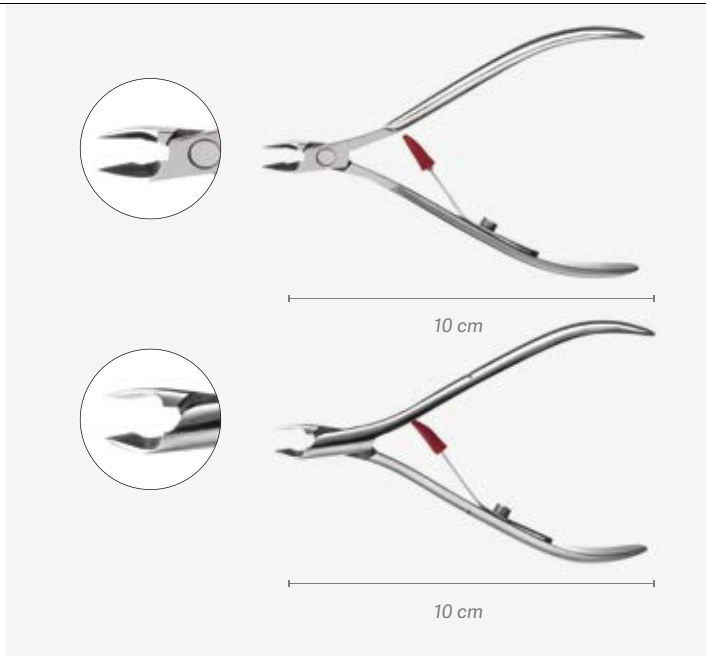

u.m.vta: 1  12

Satiniertes Giff
Manico satinato

REF.02812

Rund. Gifffläche 3 mm
Rotondo. Apertura 3 mm

REF.03018

Rund. Gifffläche 5 mm
Rotondo. Apertura 5 mm

REF.03019

Gifffläche 4 mm
Apertura 4 mm

REF.03039

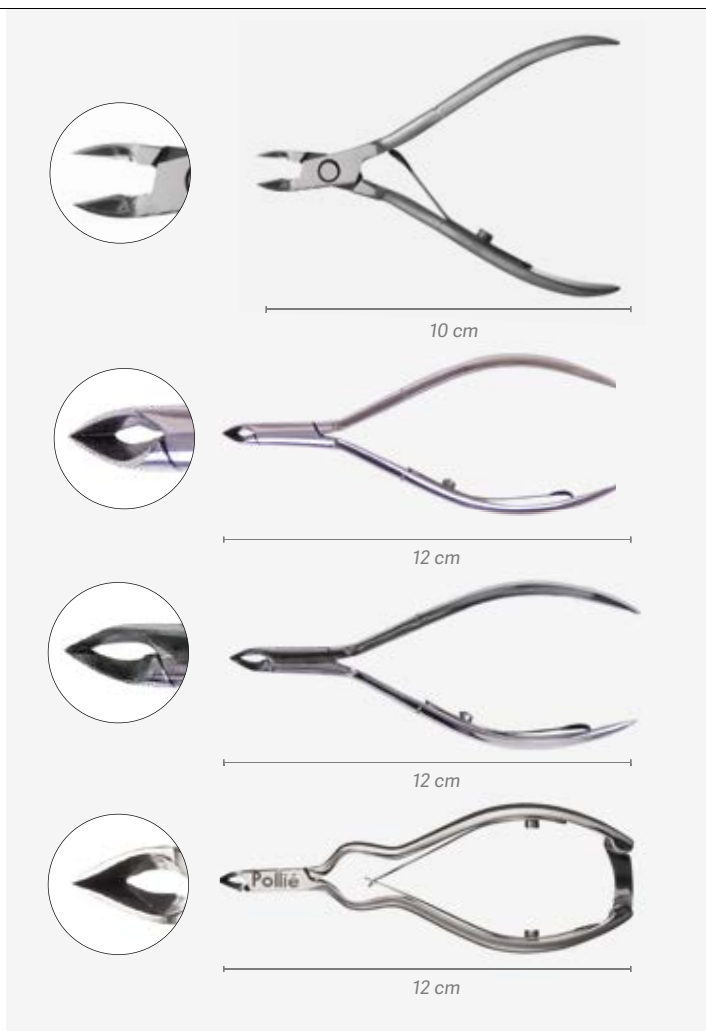

Nagelhautzange Chirurgischer Stahl Tagliacuticole Acciaio chirurgico

u.m.vta: 1  1

REF.02265 Gifffläche 2 mm eingepasst
Apertura a incastro 2 mm

REF.02266

Gifffläche 4 mm eingepasst
Apertura a incastro 4 mm

REF.02267

Gifffläche 6 mm eingepasst
Apertura a incastro 6 mm

REF.02405

Ersatzfeder + Schrauben für
Zange 02265 - 02266 - 02267
Molla di ricambio + viti pinza
02265 - 02266 - 02267

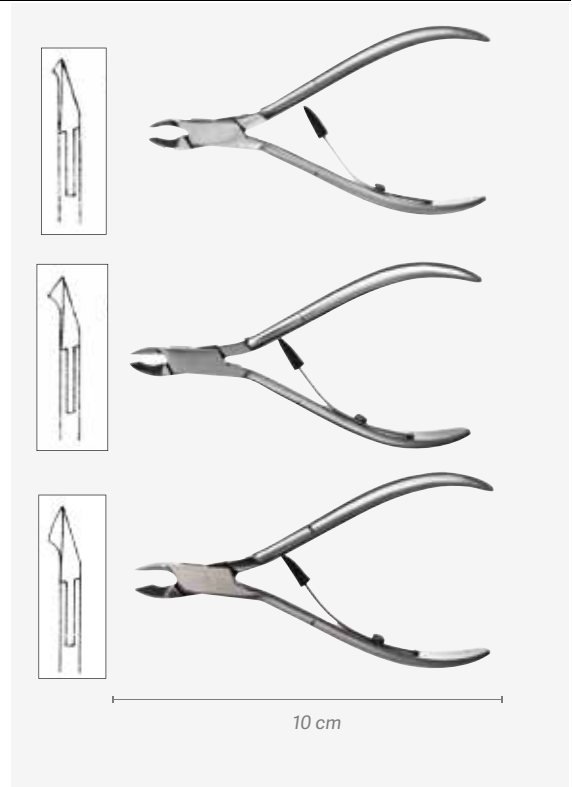

Nagelhautzange Edelstahl Tagliacuticole Acciaio inossidabile

u.m.vta: 1  12

Gifffläche 3 mm
Apertura 3 mm

REF.03685

Gifffläche 4 mm
Apertura 4 mm

REF.03686

Gifffläche 5 mm
Apertura 5 mm

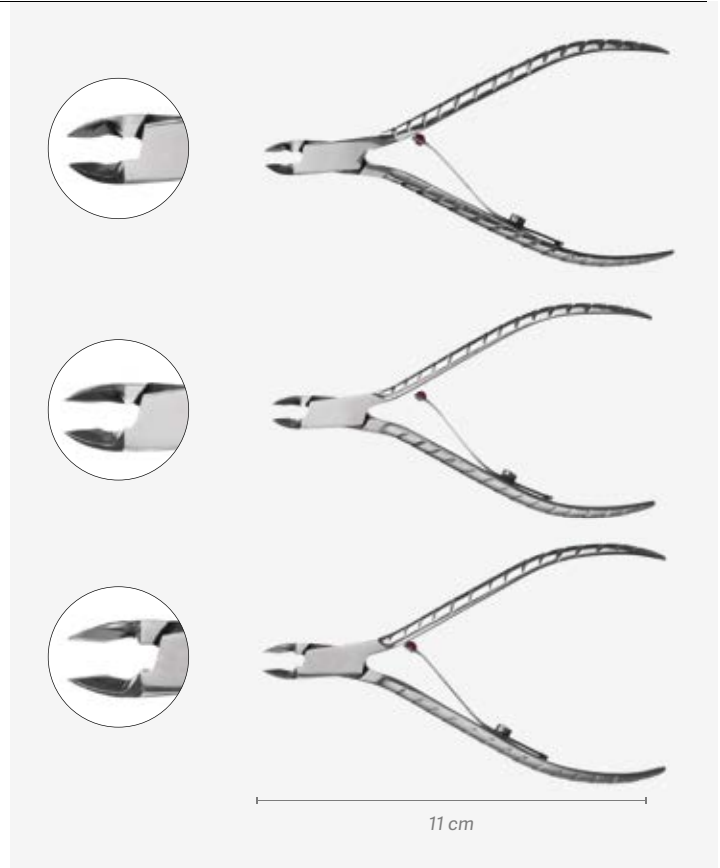
REF.03687

Zange Nagelknipser

Nail clipper

u.m.vta: 1  12

REF.01271 Edelstahl
Acciaio inossidabile



10 cm

REF.02813 Satiniert
Satinato



10 cm

REF.04693



11 cm

REF. 01276 Satiniert
Satinato



12 cm

REF.03240 Titanblau
Blu titanio



10 cm

REF.04696 Mit Innenfeder
Titanblau
Con molla interna
Blu titanio



11 cm

Nagelhautzange Tagliacuticole

u.m.vta: 12	 12
-------------	--

Weiß

Bianco

REF.01069



Weiß mit Nagelfeile

Bianco con lima

REF.02836



REF.01336



Flieder mit Gummi

Lilla con gomma

REF.04411



Farbig mit Gummi

Gomma colorata

REF.01037



Flieder mit Gummi

Lilla con gomma

REF.04589



Nagelknipser Tagliaunghie

u.m.vta: 12  12

- Klein
- Piccolo

REF.01064



- Groß
- Grande

REF.01038



Nagelknipser mit Depot Tagliaunghie con deposito

u.m.vta: 12  120

- Klein
- Piccolo

REF.04408



- Groß
- Grande

REF.04407



Nagelknipser für künstliche Fingernägel Tagliaunghie per unghie artificiali

u.m.vta: 1  12

REF.01476



Maniküre-Satz 6 Stück komplett Set manicure completo da 6 utensili

u.m.vta: 1  1

REF.02746



Etui 11 Utensilien für Maniküre Astuccio 11 utensili per manicure

u.m.vta: 1  1

REF.04882

- Kapazität für 20 Utensilien

- Capacità per 20 utensili



Etui Hautzangen und Nagelknipser
Fondina in pelle per tagliaunghie

u.m.vta: 1  10

REF.02402

- Klein
- Piccolo



u.m.vta: 1  10

REF.02403

- Groß
- Grande



Etui Zangen und Nagelknipser, schwarz
Fondina per tagliaunghie e pinze, nera

u.m.vta: 1  10

REF.02512



- Sterilisierbarer Stahl
- Acciaio sterilizzabile

Etui Zangen, kleine Nagelfeilen und Scheren
Fondina per pinzette, lime e forbici

u.m.vta: 1  10

REF.02401



Meißelhalter
Porta sgorbia

u.m.vta: 1  48

REF.02820



12 Rillen im Einzelblister
12 sgorbie in blister individuale

u.m.vta: 1  10

N°1
REF.02821



N°2
REF.02822



N°3
REF.02823



N°4
REF.02824



N°5
REF.02825



N°6
REF.02826



N°8
REF.02827



N°10
REF.02828



N°12
REF.02829



Wie bereite ich den Fingernagel für den Lack vor? Come preparare l'unghia per lo smalto?

- Die Manikürewerkzeuge, die man verwenden möchte, immer sterilisieren
- Den Fingernagel feilen und in Form bringen, je nach Geschmack des Kunden, und glätten
- Befeuchten des Fingernagels mit Wasser
- Die Nagelhaut mit einem Schieber oder Manikürestäbchen schieben
- Die Hautreste mit einer Spezial-Hautzange für Maniküre entfernen
- Mit einer Polierfeile behandeln, damit der Fingernagel nicht fettig aussieht oder glänzt
- Den Fingernagel erneut befeuchten und dann trocknen

- Sterilizzare sempre gli strumenti per manicure da utilizzare
- Lima e modella l'unghia, in base al gusto della cliente e uniforme
- Inumidisci l'unghia con acqua
- Spingi le cuticole con uno spingitore o un bastoncino
- Rimuovere le pelli con una pinza speciale per pelli da manicure
- Passare una lima lucidante per lasciare l'unghia senza gasso e senza lucentezza
- Bagna di nuovo l'unghia e asciugala



Doppelter Nagelhautschieber Edelstahl Spingicuticole doppio in acciaio inox

u.m.vta: 1  12

REF.04104



u.m.vta: 1  24

REF.04688

u.m.vta: 1  24

REF.04689

Nagelhautschieber Edelstahl Spingicuticole in acciaio inossidabile

u.m.vta: 1  24



REF.04687



u.m.vta: 1  12

REF.04105

Fingernagelbürste
Spazzolino per le unghie

u.m.vta: 1  12 



Rosa mit Giff
Rosa con manico

REF.06753

Weiß mit Giff
Bianco con manico

REF.06754



u.m.vta: 1  50 



REF.00132

Goß, zwei Seiten
Grande a due lati





u.m.vta: 24  24



REF.02185

Doppelt spezial
Doppio speciale





u.m.vta: 12  120 



REF.00774

Mit Giffen, goß
Con manici Grandi



u.m.vta: 12  120 



REF.00792

Mit Giffen, klein
Con manici piccoli



Schale Edelstahl Maniküre
Ciotola per manicure in acciaio inossidabile



u.m.vta: 10  120

325 ml

REF.03732



Schale spezial Maniküre
Ciotola speciale per manicure

u.m.vta: 1  18 

REF. 00889





Schale Fingeranfeuchter naturfarben, ergonomisch
Ciotola ergonomica per le dita in colore naturale

u.m.vta: 20  20

REF.03399



Rundpunkt ohr- und nasenschere
Forbici per naso e orecchie punta tonda



u.m.vta: 1  12 

4"

REF.07087



Baby scissors point roma
Forbici neonato point roma



u.m.vta: 1  12 

3.5"

REF.07088



3 In 1 pinching forceps
Pinze 3 in 1

u.m.vta: 1  10 

REF.07090



Professionelle Hautschere gebogen
Forbici professionali dritte per cuticole

u.m.vta: 1  30

3.5"

REF.07353



Professionelle Nagelschere gebogen
Forbici professionali dritte per unghie

u.m.vta: 1  30



3.5"

REF.07354





Hautschere gebogen



Forbici curve per cuticole

u.m.vta: 1  12 



REF.07085

u.m.vta: 1  12 

REF.04690

u.m.vta: 1  12 

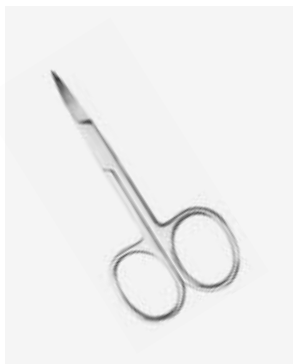
REF.01270

u.m.vta: 1  30

REF.01989

Professionel
Professionale

u.m.vta: 1  12

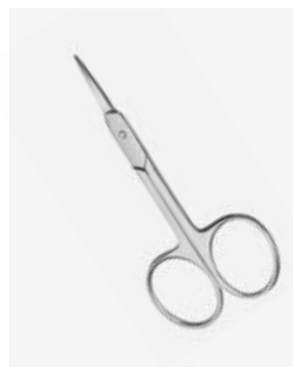

REF.03419

Feine Spitze
Professionale



Nagelschere gebogen

Forbici curve per unghie

u.m.vta: 1  12 

REF.07086





REF.01269

u.m.vta: 1  30

Professionell
Professionale

REF.01990

u.m.vta: 1  12 

REF.04691

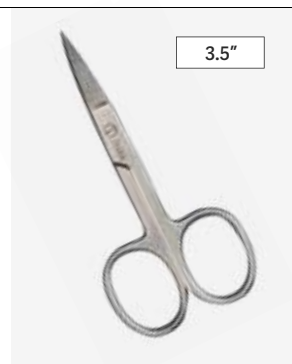

Beutel Hautschieber

Busta spingi cuticole

u.m.vta: 10  10

REF.06567



Ø 0,38 cm

7,5 cm

10 u

- Holz
- Legno

u.m.vta: 10  10

REF.01279

Ø 0,38 cm

12 cm

10 u

- Holz
- Legno

u.m.vta: 10  10

REF.02716

Ø 0,38 cm

15 cm

10 u

u.m.vta: 50  50



REF.00121



11,5 cm

50 u

- Kunststoff
- Plastica

u.m.vta: 1  10 

REF.06565





Ø 0,38 cm

7,5 cm

100 u

- Holz
- Legno

u.m.vta: 1  10 

REF.06566





Ø 0,38 cm

15 cm

100 u

- Holz
- Legno

u.m.vta: 1  80 

REF.00123

Ø 0,38 cm

12 cm

100 u

- Holz
- Legno

u.m.vta: 1  10

REF.04525

Ø 0,38 cm

7,5 cm

1000 u

- Holz
- Legno

REF.04526

Ø 0,38 cm

12 cm

Zange Nagelknipser Pediküre Tagliaunghie pedicure

u.m.vta: 1  12**REF.03017**

Satinierter Griff
Edelstahl
*Manico satinato
Acciaio inossidabile*



12 cm

REF.01475

Mit Verschluss,
Hochglanzoberfläche
Con sicura. Finitura lucida.



12 cm

REF.03016

Satinierter Griff
Edelstahl
*Manico satinato
Acciaio inossidabile*



14 cm

REF.01474

Mit Verschluss,
Hochglanzoberfläche
Edelstahl
*Con sicura. Finitura lucida.
Acciaio inossidabile*



14 cm

u.m.vta: 1  10**REF.04695**

Matt, mit
Verschluss
*Con sicura.
Finitura opaca.*



12 cm

REF.04694

Matt, mit
Verschluss
*Con sicura.
Finitura opaca.*



14 cm

Zange Nagelknipser Pediküre Tagliaunghie pedicure

u.m.vta: 1  10 

REF.07089

Doppelt gerade mit
federn
*Doppio dritto con
molle*



REF.07136

Schräg mit
Federn
*Obliquo con
molle*

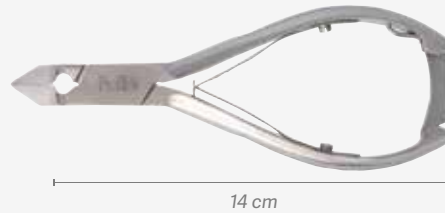

Nagelknipser Pediküre Titanblau Tagliaunghie per pedicure Blu titanio

u.m.vta: 1  12

REF.03241

Mit Verschluss
Con sicura



REF.03242

Mit Verschluss
Con sicura



Gelenkzange für Podologen Pinza podologica articolata

u.m.vta: 1  1

REF.02271



Schale Edelstahl Pediküre

Ciotola per pedicure in acciaio inossidabile

u.m.vta: 1  10

7 L

REF.03733



Beutel Zehentrenner Pediküre



Separadita per pedicure

u.m.vta: 50  50

REF.00846

- 2 Stück
- Pediküre
- Weiß

- 2 unità
- Pedicure
- Bianco

u.m.vta: 1  12 

REF.06755

- 2 Stück
- Silikon
- 2 unità
- Silicone



Hornhautentferner

Limacalli elettrico

u.m.vta: 1  24

REF. 04810



Ersatzteile

Ricambi

Beutel 2 Nagelfeilen

Confezione da 2 lime

REF. RE04810/01

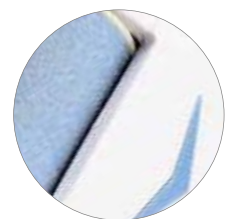

Dieser Hornhautentferner ist ein innovatives Gerät, das geschaffen wurde, um trockene, spröde Haut und die Schwielen an den Füßen zu lindern. Die Rolle dreht sich um 360 Grad bei einer Geschwindigkeit von 40 Mal pro Sekunde. Das Gerät arbeitet viel schneller und sicherer als konventionelle Hornhautentferner. Ist dafür gedacht, Hautverdickungen an Füßen und Fersen zu behandeln. Mit Batterien

Questo limacalli è un dispositivo innovativo creato per ammorbidire la pelle secca e ruvida delle callosità dei piedi. Il suo rullo ruota di 360 gradi a una velocità di 40 giri al secondo. Funziona più velocemente ed è più sicuro dei tradizionali limacalli. È progettato per ammorbidire la pelle spessa sui piedi e sui talloni. Con batterie

Crema TASSEL Füße

Crema piedi TASSEL

u.m.vta: 1  12

400 ml

- Feuchtigkeitsspendend intensiv
- Crema idratante intensiva

REF.06430

Peeling TASSEL Füße

Scrub per i piedi TASSEL

u.m.vta: 1  12



400 ml

- Mit Aprikosenkern
- Con nocciolo di albicocca

REF.06431

Flüssiger Enthärter für Verhärtungen und Schwielen

Liquido ammorbidente per calli e duroni

u.m.vta: 1  12 

500 ml

REF.04811

Dank des flüssigen Enthärters von Pollié ist es einfacher, Schwielen und Verhärtungen zu entfernen, um die Füße jung und gepflegt zu halten.

Grazie al liquido ammorbidente Pollié è più facile rimuovere calli e duroni per sfoggiare piedi giovani e curati.



06430



06431



Hornhautentferner Pediküre Raschietto per pedicure

u.m.vta: 1	 48	
------------	--	---

REF.06033

- Kunststoff (waschbar)
- Plastica (lavabile)

REF.06034

- Kunststoff (waschbar)
- Gebogen
- Plastica (lavabile)
- Curvo

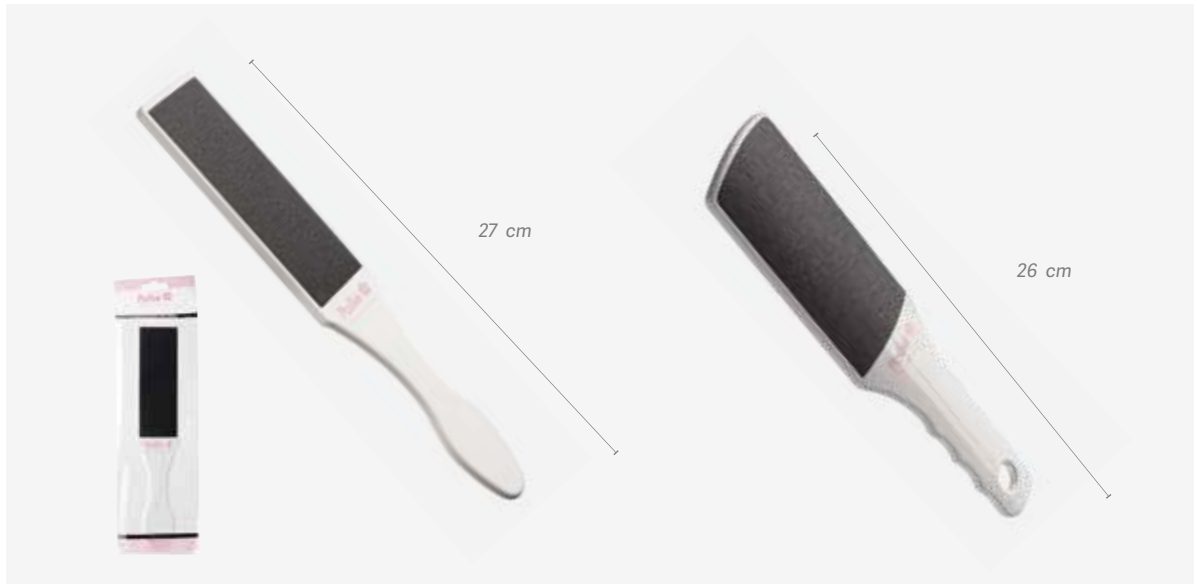

u.m.vta: 12	 12
-------------	--

REF.01068

- Mit Metall
- Metallico



u.m.vta: 1	 30
------------	--

REF.04416

Transparenter Hornhautentferner aus hartem, widerstandsfähigem Kunststoff. Doppelseitige Nagelfeile aus Keramik

Raschietto trasparente in plastica rigida e resistente. Lima in ceramica doppio lato





Hornhautentferner Pediküre Raschietto per pedicure

u.m.vta: 12	 120
-------------	---

REF.04592

- Kunststoff, groß
- Plastica, Grande



u.m.vta: 1	 100	
------------	---	---

REF.01073



Hornhautentferner aus Metall Pediküre, mit Griff aus Softgummi Raschietto metallico per pedicure con impugnatura in morbida gomma

u.m.vta: 1	 12	
------------	--	---



REF.06606/58



REF.06606/70

Hornhautentferner von Podorape, doppelseitig, waschbar

Raschietto Podorape doppio lato lavabile

u.m.vta: 1  12 

REF.06611/58

REF.06611/59

REF.06611/70





Hornhautentferner von Podorape, weiß, blau und rosa, doppelseitig, mit einer harten und einer weichen Seite. Waschbar mit unzerstörbarem Griff, für Podologen, ultra-widerstandsfähig und ideal für Diabetiker aufgrund der Wirksamkeit und der Sicherheit des Kornes.

Raschietto Podorape bianco, doppio lato blu e rosa, uno forte e uno delicato. Lavabile con manico infrangibile, studiato per podologi, ultra resistente e ideale per l'utilizzo da parte dei diabetici grazie all'efficacia e alla sicurezza della gana.

Hornhautentferner Pediküre

Raschietto per pedicure

u.m.vta: 1  12 

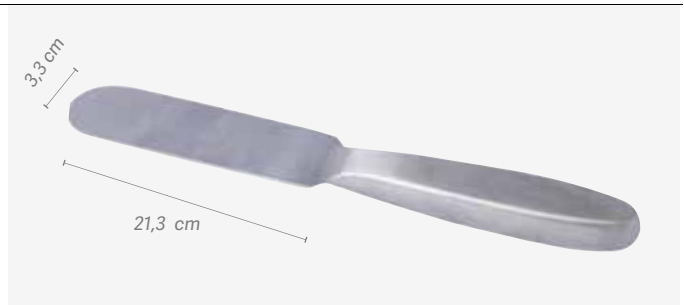

REF.06709

- Material: Edelstahl
- Mit Metallgriff
- Materiale: acciaio inossidabile
- Con manico in metallo



50 Schleifpapiere für Hornhautentferner

50 fogli per raschiacalli

u.m.vta: 1  48 

80



REF.06710

180

REF.06711





Bimsstein
Pietra pomice

u.m.vta: 1  48 

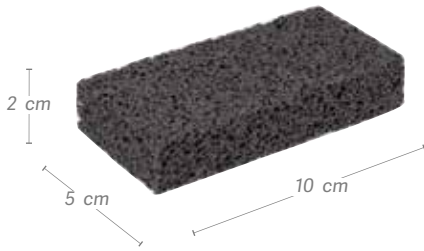
REF. 06518





- Schwarz, klein
- Mit offener Porenstruktur
- Piccola, nera
- Con struttura a poro aperto

u.m.vta: 1  48 

- Weiß, klein
- Piccola, bianca

REF. 06517





u.m.vta: 1  60 

- Gefärbt, groß
- Colorata Grande

REF. 00942



u.m.vta: 1  60 

- Verschiedene Farben
- Colori assortiti

REF. 02757

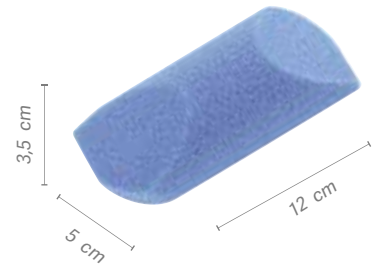

Bimsstein mit Giff
Pietra pomice con manico

u.m.vta: 20  60

REF.03061

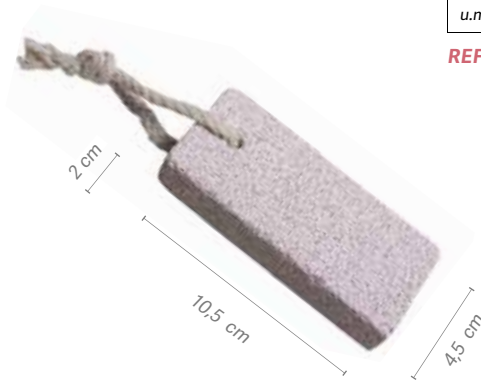

u.m.vta: 20  60

REF.03062



u.m.vta: 10  30

- Fisch
- Pesce

REF.03063





u.m.vta: 20  60

- Oval
- Ovale

REF.03065



Hornhauthobel Tagliacalli

u.m.vta: 12  12u.m.vta: 12  12u.m.vta: 7  12 

REF.01102

- Rasierklinge inbegiffen
- Con lametta inclusa

REF.01400



- Kunststoffgiff
- Ohne Rasierklinge
- Manico in plastica
- Senza lama

REF.01401

- Rostfreies Metall
- Ohne Rasierklinge
- Metallo inossidabile
- Senza lama



Dispenser 100 Klingen für Hornhauthobel Pollié Dispenser da 100 lamette per tagliacalli Pollié

u.m.vta: 1  100 

72 g

REF.06459

- Maße Box mit 100 Stück:
13 cm x 7 cm x 1 cm
- Gewicht: 72 g
- Maße Klinge:
2,24 cm x 0,01 cm
- "Made in Germany"
- Scatola da 100 unità:
13 cm x 7 cm x 1 cm
- Peso: 72g
- Misure lametta:
2,24 cm x 0,01cm
- "Made in Germany"



Austauschklingen aus Stahl für Hornhauthobel. Flache und sehr feine Oberfläche. Sichere Qualitätsklingen mit Schnittgarantie zum Entfernen von überschüssigen Schwielen und/oder Verhornungen an den Füßen, dank seiner zweiseitig Präzisionsklinge und der fein geschnittenen Ränder. Passen sich an alle Standard-Hornhauthobel an.

Lamette di ricambio in acciaio per tagliacalli. Superficie piatta e molto fine. Lamette di qualità con garanzia di taglio e sicurezza, per rimuovere calli in eccesso e/o durizie dei piedi grazie alla lama di precisione e ai due bordi dal taglio di precisione. Si adattano a tutti tagliacalli standard.

Reflexmassagegerät Massaggio riflessivo

u.m.vta: 1		4
------------	---	---

REF. 04809

- Spa-Badewanne für Fußmassage
- Leistung: 60 W
- Vibrierende Massage mit Sprudelbad
- Gummieinlagen rutschfest

- *Vasca da bagno spa massaggio per i piedi*
- *Potenza: 60W.*
- *Vibrazione e massaggio con bolle*
- *Suola in gomma antiscivolo*

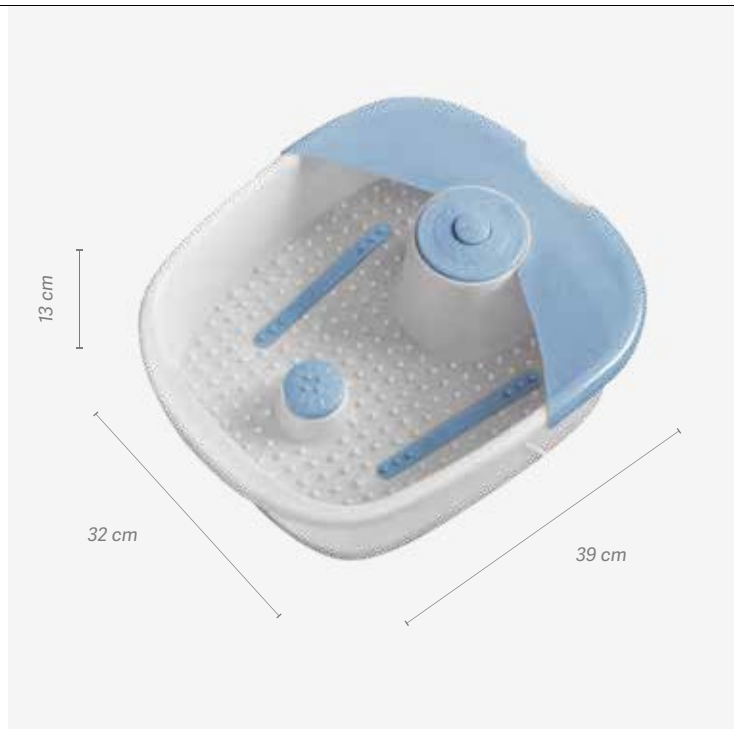

Reflexmassagegerät Massaggio riflessivo

u.m.vta: 1		2
------------	---	---

REF. 04588

- Leistung: 60 W
- Entspannende Massage für die Füße
- 3 in 1: Aufheizen des Wassers, Sprudelbad und Vibration
- Intensive Fußreflexologie, Anhaftung für Massage inbegriffen
- Mit Entwässerung für ein leichteres Leeren
- Geeignet für Füße bis Größe 44. Rutschfest
- Automatische Wärmefunktion
- Länge des Anschlusskabels 175 cm

- *Potenza: 60W.*
- *Massaggiatore rilassante per i piedi*
- *3 in 1: riscaldamento dell'acqua, bolle e vibrazione*
- *Riflessologia plantare intensa, accessorio per massaggio incluso*
- *Con scarico per uno svuotamento più facile*
- *Adatto per piedi fino alla taglia 44 Antiscivolo*
- *Funzione di riscaldamento automatico*
- *Lunghezza cavo di collegamento 175 cm*



MEDISANA®

AQUATHERM: 3 IN 1

AQUATHERM: 3 in 1

u.m.vta: 1	 2
------------	---

REF. 02309

MEDISANA®

- Leistung: 390 W
- 3 in 1: Massage durch Vibration und Sprudelbad mit Infrarotwärme
- Aufheizen des Wassers verstellbar von 20°C bis 48°C
- Timer: 20/30/40/50/60 Minuten
- Am Bildschirm werden die Zeit und die Wassertemperatur angezeigt
- Automatische Funktionen Infrarot- und Wärmelampe
- Massageroller zum Massieren der Innenseite der Füße
- Luftausgänge ergonomisch angebracht
- Massageroller mit abnehmbarer Basis
- Doppelt dickes Außengehäuse zur Erhaltung der Wärme
- Intensive Fußreflexzonenmassage
- Für Füße bis Größe 46
- Maße: 38,6 x 24,3 x 45,9 cm

- Potenza: 390W.
- 3 in 1: massaggio vibrante e bolle con calore a infrarossi
- Riscaldamento dell'acqua regolabile da 20°C a 48°C
- Timer: 20/30/40/50/60 minuti
- L'ora e la temperatura dell'acqua vengono visualizzate sul display
- Funzioni automatiche di luce a infrarossi e calore
- Rulli massaggianti per massaggiare la parte interna dei piedi
- Prese d'aria posizionate ergonomicamente
- Rulli massaggianti alla base smontabili
- Strato esterno a doppio spessore per mantenere il caldo
- Riflessologia plantare intensa
- Per piedi fino alla taglia 46
- Misure: 38,6 x 24,3 x 45,9 cm



Schutzhülle

Rivestimento protettivo

u.m.vta: 1	 10	
------------	--	---

REF. 06109



- Beutel mit 100 Stück Schutzhüllen aus Polyethylen hoher Dichte für Fußbadewannen.
- Maße: 48 cm Breite x 45 cm Länge. Seiten aufklappbar + 15 cm, hygienisch.
- Verhindert den Kontakt der Füße des Kunden mit der Wanne.
- Transparentes Polyethylen.
- Nur einmal verwendbar.

- Confezione da 100 unità di protezione in polietilene ad alta densità per vasche per pedicure.
- Misure: 48 cm di larghezza x 45 cm di lunghezza. Lati che si dispiegano di 15 cm.
- Evita il contatto tra i piedi del cliente e la vasca da bagno.
- Polietilene trasparente.
- Monouso.



Kunststoffstifte von POLLIÉ

Matite in plastica POLLIÉ

u.m.vta: 1  12 

 Weiß · Bianco
REF.03788

 Schwarz · Nero
REF.03787

 Blau · Blu
REF.03790

 Grün · Verde
REF.03789

 Braun · Marrone
REF.03792

 Grau · Grigio
REF.03791





12,5 cm

 Hellbraun
Marrone chiaro
REF.03795

 Dunkelbraun
Marrone scuro
REF.03798

 Dunkelviolett
Viola scuro
REF.03799

 Rot · Rosso
REF.03796

 Rosa · Rosa
REF.03800



12,5 cm

 Braun · Marrone
REF.03794

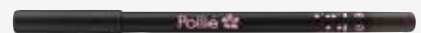



12,5 cm

Lidstift HOLZ POLLIÉ

Matita per gli occhi POLLIÉ in legno



Ophthalmologisch Getestet
Oftalmologicamente testato

u.m.vta: 1  10 

Eyeliners von Khol für die Benutzung auf der inneren und äußeren Augenlinie. Seine cremige Textur ist mild für die sensible Innenlinie und für die delikaten Stellen der Augen.

Matita eyeliner Khol da utilizzare sul contorno occhi interno ed esterno. La sua consistenza cremosa è delicata sulla linea interna sensibile e sulle zone delicate degli occhi.

Schwarz Khol · Nero Khol

REF.06398

Schmaler Stift, extrudiert, aus Holz.
Anwendung auf der inneren und äußeren
Augenlinie.
*Matita sottile in legno estruso. Applicazione
sulla linea degli occhi interna ed esterna*

Schwarz · Nero

REF.06399

Seine hohe Pigmentkonzentration bewirkt,
dass die Farbe widerstandsfähig und haltbar
am Tränensack ist
*La sua alta concentrazione di pigmenti
rende il colore resistente e di lunga durata
nel condotto lacrimale.*

Braun · Marrone

REF.06400

Weiß · Bianco

REF.06402

Grün · Verde

REF.06403

Grau · Grigio

REF.06404

Blau · Blu

REF.06405

Lila · Viola

REF.06456

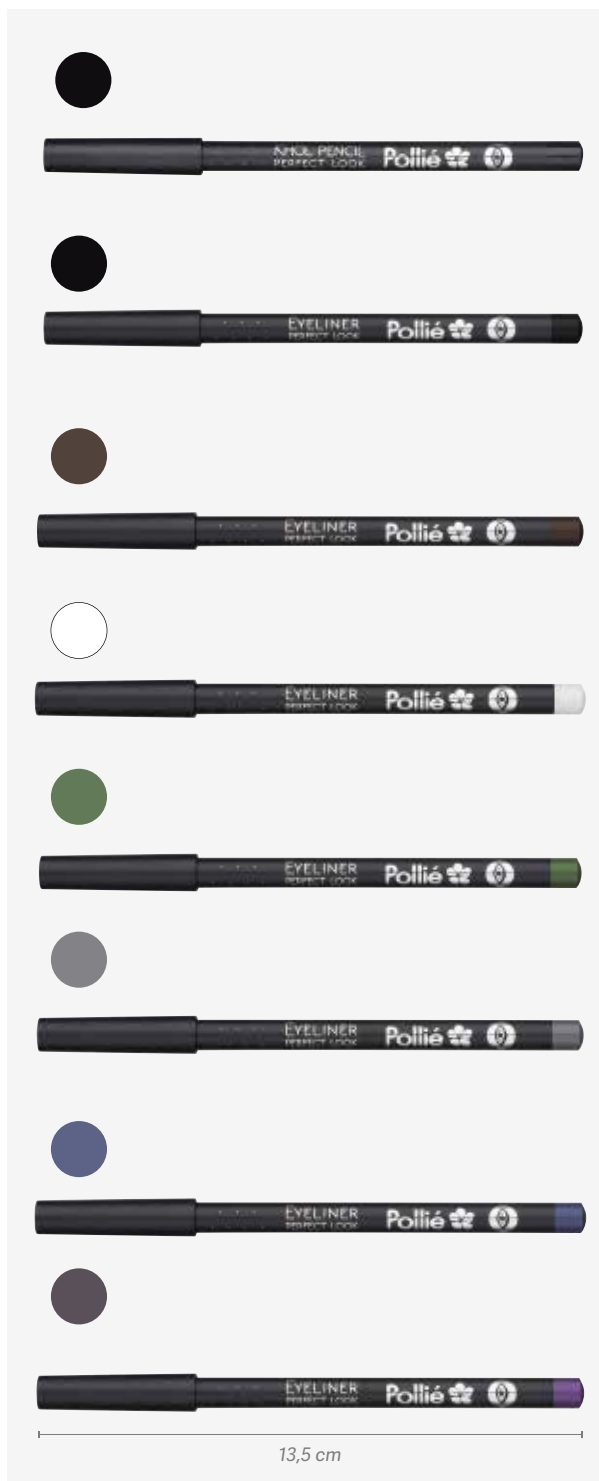

Lippenstift HOLZ POLLIÉ

Matita per le labbra POLLIÉ in legno



u.m.vta: 1 10

Feiner Stift extrudiert aus Holz. Anwendung für Lippenkontur und Lippen.
Intensiver Lipliner zur Definition der Lippen in nur einem Durchgang. Angenehm, cremig und leicht mit einem Pinsel aufzutragen.
Reichhaltige Textur und intensive Farbe, die es Ihnen erlaubt, die neue Art des Auftragens des Lipliners in matter Farbe auszuprobieren.

Matita sottile in legno estruso. Applicazione su labbra e contorno labbra.

Matita per labbra intensa per definire le labbra in una passata. Si applica in modo piacevole, è cremosa e facile da applicare con un pennello. Texture ricca e colore intenso che ti permettono di provare il nuovo modo di usare la matita per le labbra con un colore opaco.

REF.06406

Hellbraun
Marrone chiaro

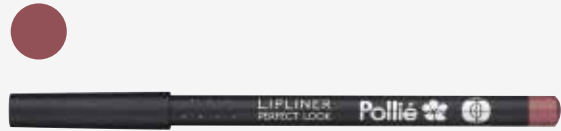

REF.06407

Weinrot
Vino



REF.06408

Mittelbraun
Marrone medio



REF.06409

Dunkelrot
Rosso scuro



REF.06410

Rosa
Rosa

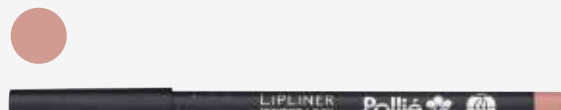

13,5 cm

Augenbrauenstift Holz POLLIÉ

Matita per le sopracciglia POLLIÉ in legno



Ophthalmologisch Getestet
Oftalmologicamente testato

u.m.vta: 1 10

Feiner Stift, extrudiert aus Holz. Anwendung auf die Augenbrauen

Augenbrauenstift mit mischbarer trockener Textur zum perfekten Definieren, Färben und Auffüllen der Augenbrauen mit Strichen in milden Farben. Verwenden Sie die Abdeckung der Bürste, um die Augenbrauen vor der Anwendung zu kämmen und sogar, um die aufgetragene Farbe zu mischen. Natürliches Finish, hält mehrere Stunden.

Matita sottile in legno estruso. Applicazione sulle sopracciglia

Matita per le sopracciglia sfumabile a secco per definire, colorare e riempire perfettamente le sopracciglia con pennellate di colori tenui. Usa il cappuccio del pennello per pettinare le sopracciglia prima dell'applicazione e anche per sfumare il colore applicato. Finitura naturale che dura per ore.

REF.06396 Dunkelbraun
Marrone scuro



REF.06397 Hellbraun
Marrone chiaro



REF.06455 Schwarz
Nero

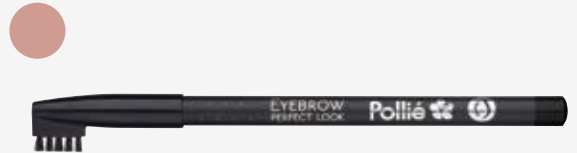

13,5 cm

Verkaufsträger für Lid-, Augenbrauen- und Lippenstifte

Espositore per matite per occhi, sopracciglia e labbra

u.m.vta: 1 1

16 Zellen
16 celle

Leer
Vuoto

REF.06807

REF.06807/01



Wasserfester veganereyliner 4ml Eyeliner waterproof vegan 4ml



u.m.vta: 1  12

REF.07447

- Augenärztlich getestet / vegan / wasserfest
- + bei 12er Bestellung Aufsteller gratis
- Test oftalmologico / Vegano / Waterproof
- Con espositore gratuito da 12 unità



Wimpernmaske Mascara

u.m.vta: 1  12 

Ophthalmologisch getestet
Oftalmologicamente testato

Glamglam Volumen und Intensität Glamglam volume e intensità

REF.06826

Waterproof
4D Volumen
Mit natürlichen Wachsen

*Resistente all'acqua
Volume 4D waterproof
Con cere naturali*



Intensifier schwarz intensiv Intensifier nero intenso

REF.06827

Hauttest natürliche
Wachse
X3 schwarz

*Testato dermatologico Cere
naturali
X3 nero*

Abschminkschwamm Zellulose

Spugna struccante in cellulosa

u.m.vta: 12  360

REF.01355



REF.01355/77

u.m.vta: 2160  2160

Unverpackt · Sfuse





REF.01355/70/01



REF.01355/77/01

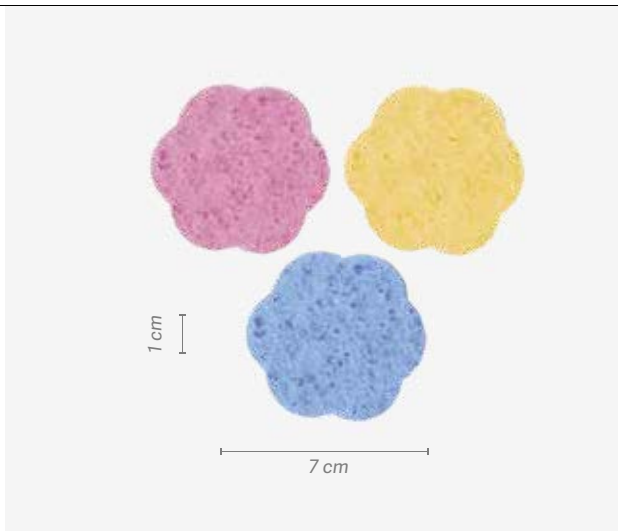

REF.01355/59/01

u.m.vta: 12  240

REF.01938



REF.01938/77

u.m.vta: 1080  1080

Unverpackt · Sfuse



REF.01938/70/01



REF.01938/77/01





REF.01938/59/01



Natürlicher Schwamm



Spugna naturale

u.m.vta: 1  16 

REF.02478



Natürlicher Schwamm Bad
Spugna naturale per il bagno

u.m.vta: 1  72 

REF.02453





Zum Abschminken, von sanfter Textur, indiziert für sensible und empfindliche Haut. Hypoallergen
Per struccare, dalla texture morbida, indicata per pelli sensibili e delicate. Ipoallergenico

Beutel 2 feine flache Abschminkschwämme
Confezione da 2 spugne piatte sottili per rimuovere il trucco

u.m.vta: 12  240

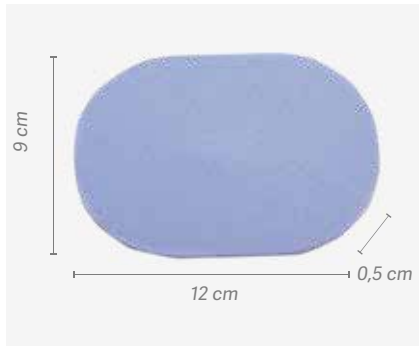
REF.03166



u.m.vta: 12  180

REF.03165

Feucht
Umide





Beutel Handtuch feiner Abschminkschwamm
Asciugamano spugna sottile per rimuovere il trucco

u.m.vta: 12  180

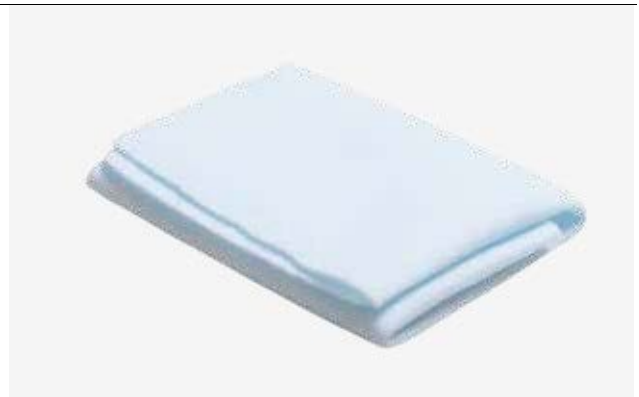
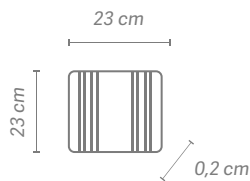
REF.03168



Schwamm latexfrei - polyurethan
Spugna senza lattice - poliuretano

u.m.vta: 1  15 

REF.07128

REF.07127



SCAN
ME!



Sie können den Schwamm feucht oder trocken verwenden. Trocken eignet er sich für das Auftragen von Make-up in Puderform wie Kompaktpuder, Rouge, Lidschatten... Feucht dient er zum Auftragen von Unterlagen, Cremes, Lotionen und sonstigen flüssigen Make-up-Produkten.

Puoi usare la spugna bagnata o asciutta. Per uso a secco, è adatta per applicare i trucchi in polvere come ciprie compatte, fard, ombretti, ecc... Per uso bagnato, è adatta per applicare fondotinta, creme, lozioni e altri prodotti per il trucco liquidi.

Beutel 2 zylindrische Make-up-Schwämme Confezione da 2 spugne cilindriche per il trucco

u.m.vta: 12  180

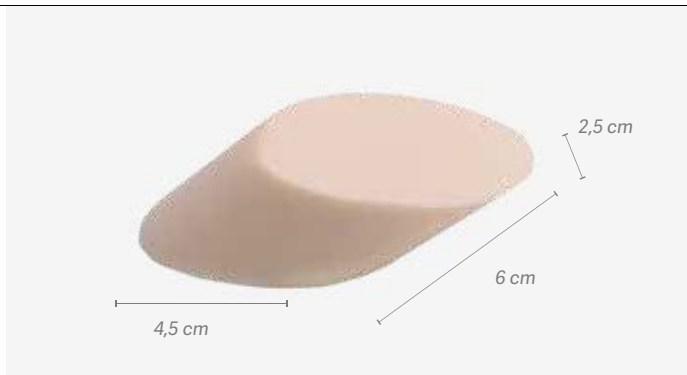

REF.03167



Make-up-Schwämme Spugnette per il trucco

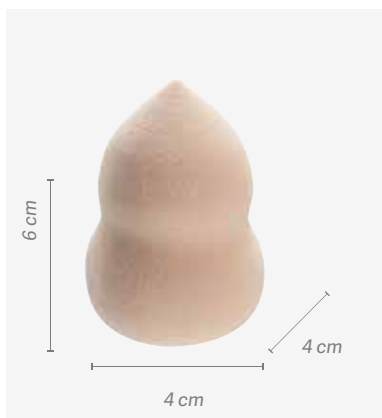

u.m.vta: 1  300

REF.03559

u.m.vta: 12  240

Make-up-Schwamm rosa Satz-4
Set di spugnette per trucco rosa - 4u

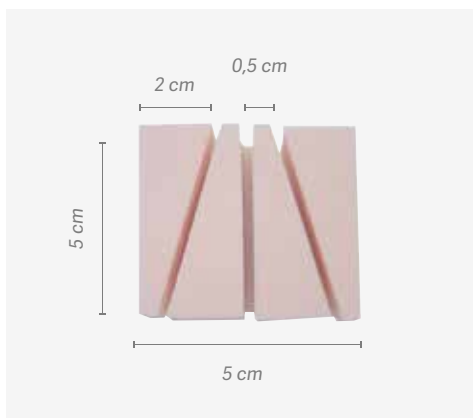
REF.01361

u.m.vta: 12  360

REF.01356

Látex NBR
Lattice NBR

u.m.vta: 12  240

REF.02898

Látex NBR
Lattice NBR

u.m.vta: 12  240

REF.02897

Látex NBR
Lattice NBR

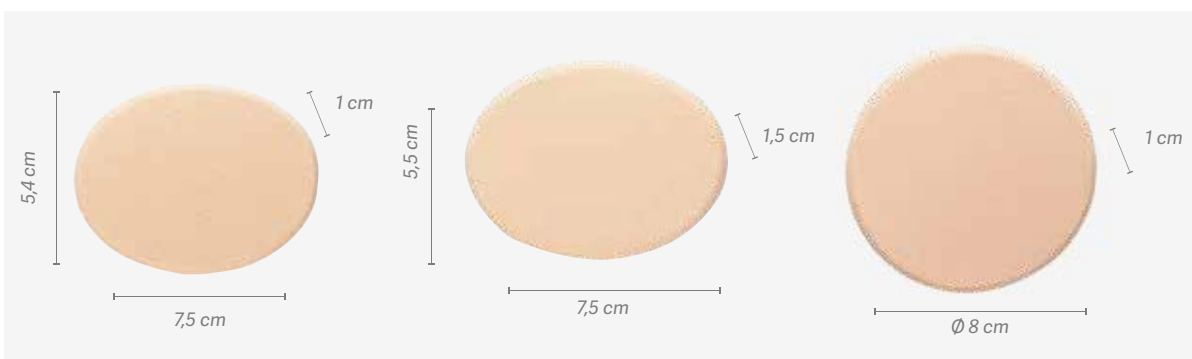

Make-up-Schwamm Latex NBR
Spugnetta per trucco in lattice NBR

u.m.vta: 12  360

REF.01409

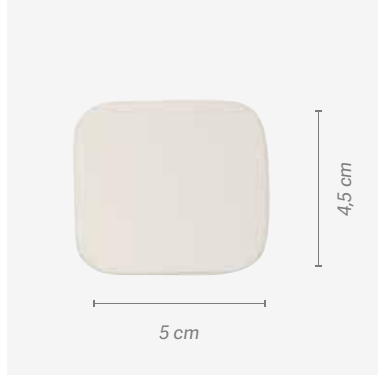

u.m.vta: 12  12

REF.02899



Beutel 2 Make-up-Schwämme Latex
Confezione da 2 spugnette per il trucco in lattice

u.m.vta: 12  360

REF.01410



u.m.vta: 12  360

REF.01357



Schwamm Make-up
Spugnetta per il trucco

u.m.vta: 12  360

REF.01354

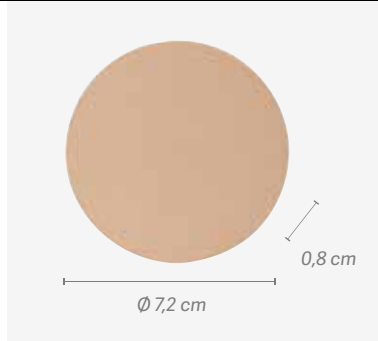

u.m.vta: 12  36

REF.01358

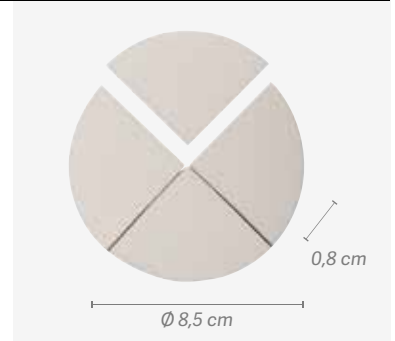

u.m.vta: 12  240

REF.02675

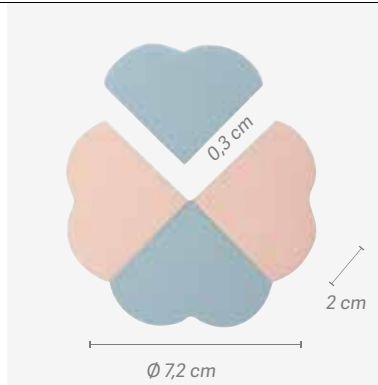

u.m.vta: 12  12

REF.01459

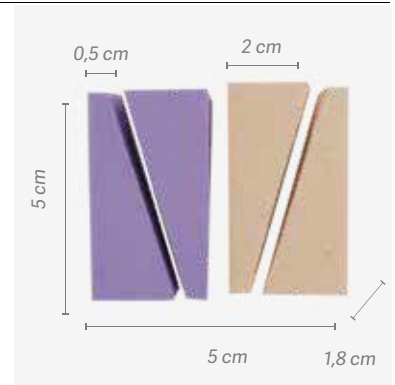

- Beutel 4 Schwämme Herzform
- Confezione da 4 spugne a cuore

- Beutel 12 Latexschwämme
- Confezione da 12 spugne in lattice

Beutel Schwämme Make-up Farben Sacchetti di spugne per il trucco colorate

u.m.vta: 1  252 8 Schwämme
8 spugne



REF.01481

u.m.vta: 1  12 24 Schwämme
24 spugne



REF.02671

u.m.vta: 1  300 4 Schwämme
4 spugne



REF.02672

u.m.vta: 1  12 Satz 3 Schwämme + 2 Quasten
Set 3 spugne + 2 applicatori cipria

REF.02673

u.m.vta: 1  24 6 Schwämme
6 spugne

REF.02674

u.m.vta: 1  120 33 Schwämme
33 spugne

REF.02676



Make-up-Quaste Applicatori di cipria

u.m.vta: 12  12

REF.01360

- Rosa
- Rosa

u.m.vta: 12  48

REF.01411

- Mittelgroß
- Media

u.m.vta: 12  36

REF.01359

- Groß
- Grande



Ø 61 mm





Ø 70 mm



Ø 85 mm



ANGLED Rougepinsel
Pennello per blush ANGLED

u.m.vta: 1		12	
------------	---	----	---

REF.07416

ANGLED Rougepinsel
Pennello per blush ANGLED





u.m.vta: 1		12	
------------	---	----	---

REF.07408

Pinsel erröten
Pennello per blush





u.m.vta: 1		11	
------------	---	----	---

REF.07418

Mischpinsel
Pennello per sfumare





Mischpinsel
Pennello per sfumare

u.m.vta: 1		1	
------------	---	---	---

REF.07419





Mischpinsel
Pennello per sfumare

u.m.vta: 1		50	
------------	---	----	---

REF.07420



Make-up-Pinsel POLLIÉ: Griff aus Kunststoff, Haare synthetisch Pennelli per il trucco POLLIÉ: manico in plastica, pelo sintetico

u.m.vta: 1  6 

- **PROFESSIONELLE ERGEBNISSE:** professioneller Make-up-Pinsel aus synthetischen Borsten von erster Qualität für ein präzises, sanftes und streifenfreies Auftragen. Verwöhnen Sie Ihre Haut mit sanften und pflegeleichten Make-up-Pinseln, die frei von Grausamkeiten gegenüber Tieren sind
- **UNIVERSELL:** umfasst eine breite Palette an ovalen Pinseln für die Nutzung mit allen Produkten wie Contouring, Base, Korrekturmittel für Augenringe, Staub...
- **FLEXIBEL:** biegsam konzipiert, um ein einfaches Auftragen des Make-up an Stellen mit schwierigerem Zugang zu bieten
- **SANFTES UND PRÄZISES AUFTRAGEN:** die sanften Borsten von hoher Qualität gewährleisten, dass die Produkte wie Unterlagen, Korrekturflüssigkeiten, BB-Cremes, Rouges und Pulver gleichmäßig und sanft aufgetragen werden können.

- **RISULTATI PROFESSIONALI** - Pennelli per trucco professionali realizzati con setole sintetiche premium per un'applicazione precisa, liscia e senza righe. Coccola la tua pelle con pennelli per il trucco morbidi, facili da pulire e senza crudeltà per gli animali.
- **MULTIUSO** - Comprende un'ampia gamma di pennelli ovali da utilizzare con tutti i prodotti come contouring, fondotinta, correttore, cipria...
- **FLESSIBILI** - Progettati per piegarsi al fine di offrire una facile applicazione del trucco in aree difficili da raggiungere.
- **APPLICAZIONE DELICATA E PRECISA** - Le setole morbide e di alta qualità assicurano che prodotti come fondotinta, correttori liquidi, creme BB, fard e ciprie possano essere applicati in modo uniforme e delicato.

REF.06059



- Rund groß
- Rotondo grande

REF.06060



- Rund mittelgroß
- Rotondo medio

REF.06061



- Oval groß
- Ovale grande

REF.06062



- Oval, klein
- Ovale piccolo

REF.06063



- Rund mini
- Rotondo mini

REF.06064



- Satz 5 Bürsten
- Set 5 pennelli



Lidschatten Pinsel
Pennello per ombretto

u.m.vta: 1 25

N°7

REF.07393



N°6

REF.07394



N°5

REF.07395



N°4

REF.07396



N°3

REF.07397



N°2

REF.07398



N°1

REF.07399

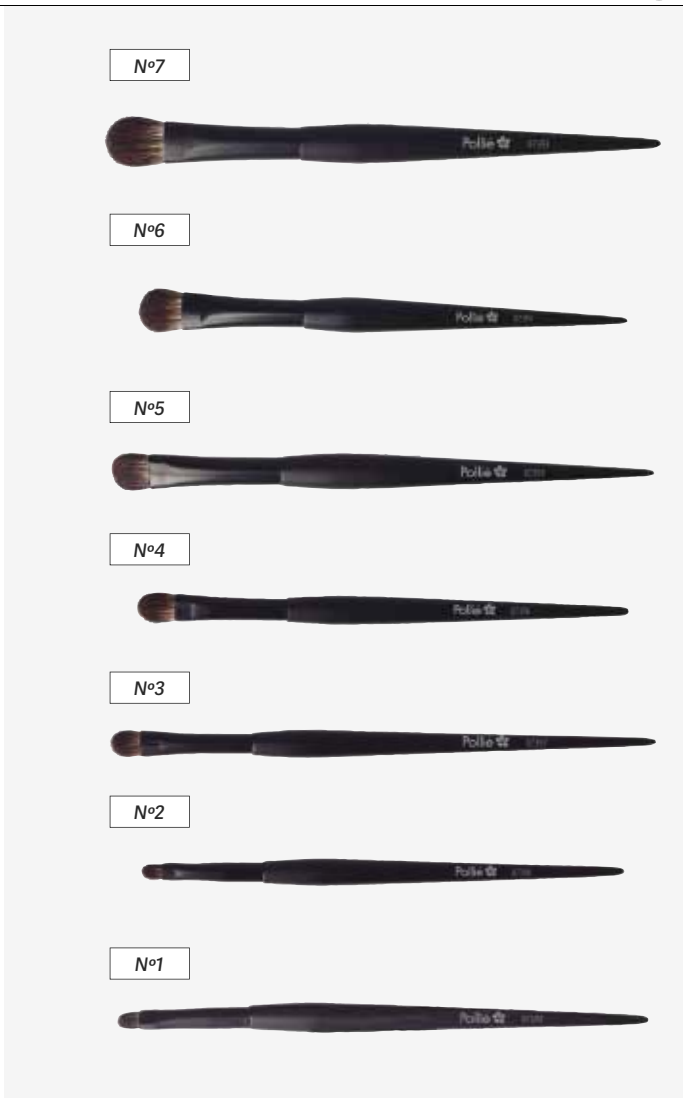

Eyeliner-Pinsel
Pennello per eyeliner

u.m.vta: 1 25

REF.07400





Eyeliner Mischpinsel
Pennello per sfumare l'eyeliner

u.m.vta: 1 25

REF.07401



Heil- / Unschärfepinsel Pennello correttivo / sfocato

u.m.vta: 1  25 

REF.07402

N°5



REF.07403

N°4



REF.07404

N°3



REF.07405

N°2





REF.07406

N°1





Konturieren von Bürstennasenschatten Pennello per contouring naso ombretti

u.m.vta: 1  25 

REF.07407





Make-up Concealer Pinsel Pennello correttore per il trucco

u.m.vta: 1  25 

REF.07409





Einziehbare Lippenbürste Pennello per labbra retrattile

u.m.vta: 1  25 

REF.07410





Brauenmischpinsel
Pennello per sfumare le sopracciglia

u.m.vta: 1  25 

REF.07411





Augenbrauen-Kammbürste
Pennello per sopracciglia

u.m.vta: 1  25 

REF.07417



FOUNDATION Pinsel
Pennello FOUNDATION

u.m.vta: 1  12 

N°4

REF.07412



N°3

REF.07413



N°2

REF.07414



N°1

REF.07415







PINSEL VON KABUKI PENNELLI KABUKI

Die Pinsel von Kabuki gelten als die besten für das Auftragen von Make-up, Lidschatten oder Rouge. Sie verschaffen ein Gefühl der extremen Sanftheit wie eine Liebkosung auf der Haut des Kunden und ermöglichen ein Finish wie ein Filmstar. Sie sind unverzichtbar für Make-up-Profis.

I pennelli Kabuki sono considerati i migliori per applicare trucco, ombretto o fard. Forniscono una sensazione di estrema morbidezza come una carezza sulla pelle della cliente e permettono una finitura cinematografica. Sono indispensabili per un professionista del trucco.

Professionelle Pinsel KABUKI Pennelli professionali KABUKI

Synthetisch
Sintetico

u.m.vta: 1  12 

Konisch
Conico

REF.04094



Eckig
Angolo

REF.04095



Rund
Rotondo

REF.04096



Flach
Piatto

REF.04097



Konisch
Conico

REF.04111



Schatten konisch
Conico per ombretto

REF.04098



Schatten eckig
Angolare per ombretto

REF.04099



Schatten flach
Piatto per ombretto

REF.04101



Pinsel KABUKI
Pennelli KABUKI

Synthetisch
Sintetico

u.m.vta: 1	 12	
------------	--	---

REF.04703

Rund
Rotondo



REF.04704

Schräg
Obliquo





REF.04705

Stumpf
Smussato



Synthetisch
Sintetico

u.m.vta: 1	 12	
------------	--	---

Rund
Rotondo

REF.04100



Schwamm Latex
Spugna in lattice

REF.04102



Konisch klein
Conico piccolo

REF.04112



Rund
Rotondo

REF.04113



Schmal
Stretto

REF.04114





Flach gerade
Piatto dritto

REF.04115



Make-up-Pinsel Pennello per il trucco

u.m.vta: 1  12 

Puderpinsel
Pennello per cipria

REF.07390



Kontur- / Farbpinsel
Pennello per contouring / coloret

REF.07391



Illuminator-Pinsel
Pennello illuminatore

REF.07392

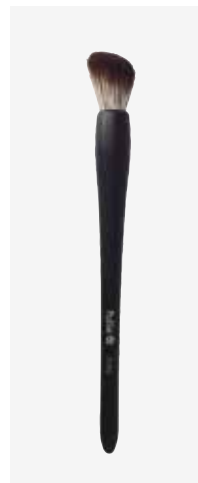

Pinsel KABUKI Pennello KABUKI

u.m.vta: 1  12

REF.03561

- Make-up-Pinsel Haar synthetisch/Taklon
- Durchmesser Haar: 27,5 mm
- Verpackung: einzelner Beutel aus Kunststoff
- Ideal für unterwegs weil platzsparend

- Pennello per il trucco con setole sintetiche/Taklon
- Diametro delle setole: 27,5 mm
- Confezione: busta di plastica individuale
- Ideale da trasportare senza occupare spazio



Kosmetikbürste und Make-up-Pinsel KABUKI NATÜRLICHES HAAR Pennello cosmetico e pennelli per il trucco KABUKI SETOLE NATURALI

u.m.vta: 12  72

REF.01812

- Kosmetikbürste für Handtasche, Kunststoffgriff
- Ziegenhaar

- Pennello cosmetico con manico in plastica
- Setole di capra

u.m.vta: 1  120

REF.03560

- Make-up-Pinsel natürliches Haar
- Durchmesser Haar: 27,5 mm
- Packaging: einzelner Beutel aus Kunststoff
- Ideal für unterwegs weil platzsparend

- Pennello per il trucco con setole naturali
- Diametro delle setole: 27,5 mm
- Confezione: Busta di plastica individuale
- Ideale da trasportare senza occupare spazio

Pinsel mit Holzgriff

Pennelli con manico in legno

u.m.vta: 1



12

**REF.02884**

Tönungscreme. Ziegenhaar
Mattifier. Pelo di capra

**REF.02885**

Rouge. Ziegenhaar
Fard. Pelo di capra

**REF.02886**

Schattierer. Eichhörnchenhaar
Sfumatore. Pelo di scoiattolo

**REF.02887**

Schattenpinsel. Eichhörnchenhaar
Pennello per ombretto in pelo di scoiattolo

**REF.02888**

Augenpinsel. Marderhaar
Pennello per gli occhi. Setole di zibellino

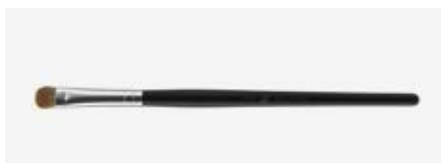
**REF.02889**

Schattenpinsel. Marderhaar
Pennello per ombretto. Setole di zibellino

**REF.02890**

Lippenpinsel. Marderhaar
Pennello per labbra. Setole di zibellino

**REF.02891**

Lippenpinsel. Marderhaar
Pennello per labbra. Setole di zibellino

**REF.02892**

Augenpinsel. Marderhaar
Pennello per gli occhi. Setole di zibellino

**REF.02893**

Pinsel Schwamm Latex
Pennello in spugna di lattice

**REF.02894**

- Pinsel für Maske
- Nylon
- Pennello per mascara
- Nylon

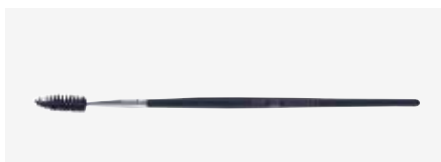
**REF.02895**

- Professioneller Kamm Maske
- Pinsel Wildschweinborsten
- Pettine professionale mascara
- Setole di cinghiale



Pinsel mit Holzgriff

Pennelli con manico in legno

u.m.vta: 1

12

**REF.01814**

- Kosmetikbürste Tönungscreme
- Ziegenhaar
- Pennello cosmetico opacizzante
- Setole di capra

**REF.01815**

- Kosmetikbürste Rouge
- Ziegenhaar
- Pennello cosmetico per fard
- Setole di capra

**REF.01816**

- Kosmetikbürste Schwamm
- Pennello cosmetico spugna

**REF.01817**

- Kosmetikbürste Augen
- Marderhaar
- Pennello cosmetico per gli occhi
- Setole di zibellino

**REF.01818**

- Schattenbürste
- Ziegen- und Ponyhaar
- Pennello cosmetico per ombretto
- Setole di capra

**REF.01819**

- Kosmetikbürste Lippen
- Ziegen- und Ponyhaar
- Pennello cosmetico per le labbra
- Setole di capra

**REF.01821**

- Schattenbürste
- Ziegen- und Ponyhaar
- Pennello cosmetico per ombretto
- Setole di capra

**REF.01820**

- Bürste Pinsel/Kamm Maske
- Wildschweinborsten
- Pennello/pettine mascara
- Setole di cinghiale



Ideal für Flüssig-Make-up

Ideale per trucco fluido

Synthetisch
Sintetico

REF.04511

- Kunststoffgriff
- Manico in plastica



**REF.04512**

- Holzgriff
- Manico in legno



Pinsel mit Holzgriff

Pennelli con manico in legno

u.m.vta: 1  12 

REF.01800

- Pinsel für Tönungscreme
- Ziegenhaar
- Pennello mattifier
- Setole di capra



REF.01801

- Pinsel für Rouge
- Ziegenhaar
- Pennello per fard
- Setole di capra



REF.01802

- Pinsel für Gesichtsmaske
- Schweineborsten
- Pennello per mascara
- Setola di maiale



REF.01803

- Fächerpinsel
- Ziegenhaar
- Pennello a ventaglio
- Setole di capra



REF.01804

- Augenpinsel
- Marderhaar
- Pennello per gli occhi
- Setole di zibellino



REF.01805

- Lippenpinsel
- Marderhaar
- Pennello per labbra
- Setole di zibellino



REF.01806

- Schattenpinsel
- Ziegen- und Ponyhaar
- Pennello per ombretto
- Setole di capra



REF.01807

- Schattenpinsel
- Ziegen- und Ponyhaar
- Pennello per ombretto
- Setole di capra



REF.01808

- Pinsel Schwamm Latex
- Pennello in spugna di lattice



REF.01809

- Pinsel für Maske
- Nylon
- Pennello per mascara
- Nylon



REF.01810

- Pinsel-Kamm Maske
- Wildschweinborsten
- Pennello/peppine mascara
- Setole di cinghiale



Verkaufsträger 66 Kosmetikpinsel
Espositore per 66 pennelli cosmetici

u.m.vta: 1  2

REF.01466



(6 Stück x Ref.-Nr.) Nähere Informationen über die Pinsel finden Sie auf Seite 757
 (6 unità x rif.) Per ulteriori informazioni sui pennelli consultare pagina 757

**Pinsel
Pennelli**

u.m.vta: 12  12

REF.01508

- Doppelter Schwamm
- Doppia spugna



u.m.vta: 12  12

REF.01509

- Pinsel / Schwamm
- Pennello / Spugna





**Spitzer
Temperamatite**

u.m.vta: 12  60

REF.01067

- Normal / dick
- Normale / spesso



u.m.vta: 12  72 

REF.06364

- Kosmetik-Doppelspitzer
- Doppio temperamatite cosmetico



**Beutel Applikatoren Schatten
Astuccio applicatori ombretto**

u.m.vta: 12  120

5 u

REF.01505

- Farben
- Colori



u.m.vta: 12  240

5 u

REF.01507



u.m.vta: 12  120

12 u

REF.01506

- Farben
- Colori





Reiniger für Silikon von Make-up-Pinseln
Detergente in silicone per pennelli da trucco

u.m.vta: 1  12

REF.04706





Rundes Etui 7 Make-up-Pinsel mit Spiegel
Astuccio rotondo 7 pennelli trucco con specchio

u.m.vta: 1  6 

REF.03562



Satz 12 Kosmetikpinsel Set di 12 pennelli cosmetici

u.m.vta: 1	 6	
------------	---	---

- Enthält: 02884, 02885, 02886, 02887, 02889, 02890, 02891, 02892, 02893, 02894, 02895
- Contiene: 02884, 02885, 02886, 02887, 02889, 02890, 02891, 02892, 02893, 02894, 02895



REF. 02896

Nähere Informationen über die Pinsel finden Sie auf Seite 755

Per ulteriori informazioni sui pennelli consultare pagina 755





Etui 7 Make-up-Pinsel synthetische Haare Astuccio 7 pennelli da trucco setole sintetiche

u.m.vta: 1	 6	
------------	---	---

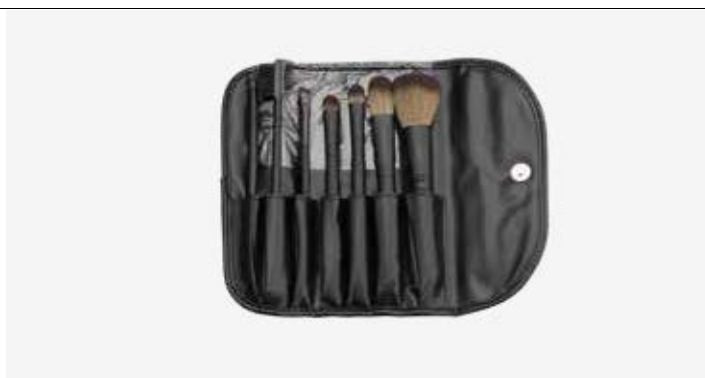
REF.03563



Etui Kosmetikpinsel (leer) Astuccio per pennelli cosmetici (vuoto)

u.m.vta: 1	 120	
------------	---	---

REF.03564



Satz 5 Pinsel Set di 5 pennelli

u.m.vta: 12	 120
-------------	---

REF.02585

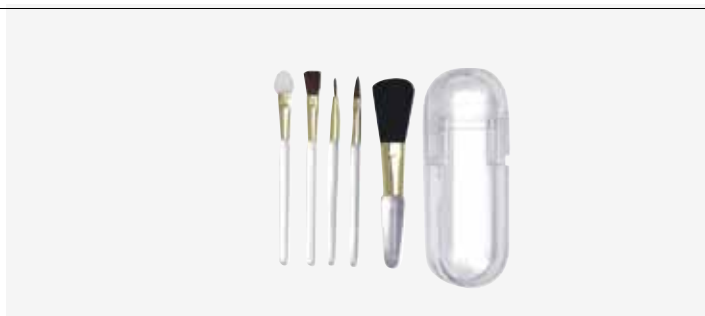

06

Wimpern Ciglia

*Komplette Wimpern, Einzelne Wimpern,
Wimpern zum Ankleben, Augenbrauen...*

*Ciglia intere, ciglia singole, ciglia adesive,
sopracciglia...*



Einzelne schwarze Wimpern POLLIÉ Ciglia POLLIÉ nere individuali

u.m.vta: 1  50

Einzelne Wimpern in 4 Schritten:

1. Reinigen Sie Ihre natürlichen Wimpern und die Augenlider, um sie frei von Make-up und Unreinheiten zu halten
 2. Entnehmen Sie die Wimpern aus der Box mit der Pinzette Pollié (Ref.-Nr. 06562)
 - Tragen Sie einen Tropfen des Klebers auf die Folie auf und befeuchten Sie den Wimpernansatz mit dem Kleber
 4. Bringen Sie die Extension auf der natürliche Wimper nahe der Wimpernlinie an, OHNE das Augenlid zu BERÜHREN. Tragen Sie so viele Wimpern auf, wie Sie möchten, um das gewünschte Ergebnis zu erzielen
- Wie entfernen Sie Ihre Wimpern von Pollié?**
Zwei Wattebäusche mit dem Wimperntferner von Pollié imprägnieren. Einen Wattebausch unter die Wimpern und einen anderen darüber anbringen. Sanft reiben, bis sich die Wimpern ablösen.

Ciglia singole in 4 passaggi:

1. Pulisci le ciglia e le palpebre naturali in modo che siano prive di trucco e impurità
 2. Rimuovi le linguette dalla scatola con le pinzette Pollié (rif 06562)
 3. Applica una goccia di adesivo sulla pellicola e impregna la base delle ciglia con l'adesivo
 4. Posiziona l'estensione sulle ciglia naturali vicino alla linea delle ciglia SENZA TOCCARE la palpebra. Applica tutte le ciglia desiderate per ottenere il risultato desiderato
- Come rimuovere le tue ciglia Pollié?**
Imbevi due pezzi di cotone con lo struccante per ciglia Pollié. Metti un batuffolo di cotone sotto le ciglia e un altro sopra. Strofini delicatamente finché le ciglia non si staccano.

REF.06508

- Kurz
- Schwarz
- Corte
- Nere

**REF.06509**

- Mittellang
- Schwarz
- Medie
- Nere

**REF.06510**

- Lang
- Schwarz
- Lunghe
- Nere

**REF.06511**

- Gemischt
- Schwarz
- Miste
- Nere

**REF.06512**

- Kurz
- Duo
- Corte
- Duo

**REF.06513**

- Mittellang
- Duo
- Medie
- Duo

**REF.06514**

- Lang
- Duo
- Lunghe
- Duo

**REF.06515**

- Kurz
- Trio
- Corte
- Trio

**REF.06516**

- Media
- Trio
- Medie
- Trio

**REF.06519**

- Lang
- Trio
- Lunghe
- Trio





Wimpern POLLIÉ schwarz 100% natürlich Ciglia POLLIÉ nere 100% naturali

u.m.vta: 1 50



Komplette Wimpern in 4 Schritten:

1. Die Wimpern an das korrekte Maß anpassen: die Wimpern nach ihrer natürlichen Wimpernlinie ausrichten und nachschneiden im Falle eines Überschusses
2. Auftragen des Klebers: eine feine Linie Kleber entlang des Streifens auftragen und 20-30 Sekunden warten. Im Falle eines Überschusses an Kleber, verwenden Sie Make-up-Entferner zum Entfernen des überschüssigen Teils
3. Auftragen der Wimpern: bringen Sie sie oberhalb der natürlichen Wimpernlinie an, mit leichtem Druck, bis sie festkleben
4. Schlussbearbeitung: verwenden Sie die Pinzetten von Pollié (Ref.-Nr. 06314) zur Anpassung der Wimpern, so dass sie gut ausgerichtet sind und fest bleiben

Wie entfernen Sie Ihre Wimpern von Pollié?

Den Wimpernstreifen losmachen, beginnend am äußersten Ende. Legen Sie die Wimpern in ihre Verpackung zurück für eine spätere Verwendung.

Ciglia complete in 4 passaggi:

1. Adatta le ciglia alla misura corretta: allinea le ciglia con la linea delle ciglia naturali e tagliale in caso di eccesso.
2. Applicazione adesivo: applica una sottile linea di adesivo lungo la striscia e attendi 20-30 secondi. In caso di adesivo in eccesso, utilizza uno struccante per rimuovere la parte in eccesso
3. Applicazione delle ciglia: incolla sopra la linea naturale delle ciglia, premendo leggermente fino a quando non si solidificano
4. Ritocco finale: utilizza le pinzette Pollié (rif. 06314) per regolare le ciglia in modo che siano ben allineate e fissate

Come rimuovere le tue ciglia Pollié?

Stacca la striscia delle ciglia partendo dal bordo esterno. Metti le linguette nella loro scatola per un uso futuro

REF.06487



N°1

REF.06488



N°2

REF.06489



N°3

REF.06490



N°4

REF.06491



N°5

REF.06492



N°6

REF.06493



N°7

REF.06494



N°8

REF.06495



N°9

REF.06496



N°10

Wimpern POLLIÉ schwarz 100% natürlich Ciglia POLLIÉ nere 100% naturali

u.m.vta: 1  50

Komplette Wimpern in 4 Schritten

1. Die Wimpern an das korrekte Maß anpassen: die Wimpern ach ihrer natürlichen Wimpernlinie ausrichten und nachschneiden im Falle eines Überschusses
2. Auftragen des Klebers: eine feine Linie Kleber entlang des Streifens auftragen und 20-30 Sekunden warten. Im Falle eines Überschusses an Kleber, verwenden Sie Make-up-Entferner zum Entfernen des überschüssigen Teils
3. Auftragen der Wimpern: bringen Sie sie mit dem Kleber oberhalb der natürlichen Wimpernlinie an, mit leichtem Druck, bis sie festkleben
4. Schlussbearbeitung: verwenden Sie die Pinzetten von Pollié (Ref.-Nr. 06314) zur Anpassung der Wimpern, so dass sie gut ausgerichtet und fest bleiben

Wie entfernen Sie Ihre Wimpern Pollié?

Den Wimpernstreifen losmachen, beginnend am äußersten Ende. Legen Sie die Wimpern in ihre Verpackung zurück für eine spätere Verwendung

Ciglia complete in 4 passaggi

1. Adatta le ciglia alla misura corretta: allinea le ciglia con la linea delle ciglia naturali e tagliale in caso di eccesso.
2. Applicazione adesivo: applica una sottile linea di adesivo lungo la striscia e attendi 20-30 secondi. In caso di adesivo in eccesso, utilizza uno struccante per rimuovere la parte in eccesso
3. Applicazione delle ciglia: incolla sopra la linea naturale delle ciglia, premendo leggermente fino a quando non si solidificano
4. Ritocco finale: utilizza le pinzette Pollié (rif. 06314) per regolare le ciglia in modo che siano ben allineate e fissate

Come rimuovere le tue ciglia Pollié?

Stacca la striscia delle ciglia partendo dal bordo esterno. Metti le linguette nella loro scatola per un uso futuro

REF.06497



N°11

REF.06498



N°12

REF.06499



N°13

REF.06500



N°14

REF.06502



N°15

REF.06503



N°16

REF.06504



N°17

REF.06505



N°18

REF.06506



N°19

REF.06507



N°20

Satz 3 einzelne Pinzetten Haar für Haar Set 3 singole pinzette

u.m.vta: 1  12**REF.06562**

Satz mit 3 Pinzetten für die Anbringung von falschen Wimpern und Wimpern-Extensions. Mit einem bequemen Etui aus Metall

Set di 3 pinzette per il posizionamento di ciglia finte ed extension per ciglia. Con una comoda custodia in metallo





WELCHE AUGENFORM HABEN SIE?

Die Feststellung der Augenform ist der erste Schritt, um zu entscheiden, welcher Stil von Wimpern für Sie passt.

RUNDE AUGEN

Klassische Wimpern, Mischung aus kurzen und langen Wimpern machen den Blick sanfter:

Ref.-Nr. 02700, 02693, 02695, 04079

MANDELAUGEN

Dichte und zu den Spitzen hin feinere Wimpern: Ref.-Nr. 02690, 02691, 02698, 02699, 02701

TIEFLIEGENDE ODER KLEINE AUGEN

Wenig dichte und lange Wimpern, um den Blick zu öffnen: Ref.-Nr. 02696, 02697, 02692, 02694

CHE FORMA DI OCCHI HAI?

Determinare la forma degli occhi è il primo passo per decidere quale stile di ciglia è giusto per te.

OCCHI ARROTONDATI

Ciglia classiche, mix di corte e lunghe, ammorbidiscono lo sguardo:

rif. 02700, 02693, 02695, 04079

OCCHI A MANDORLA

Ciglia dense e sottili verso le estremità: rif. 02690, 02691, 02698, 02699, 02701

OCCHI PROFONDI O PICCOLI

Ciglia rade e lunghe per aprire gli occhi: rif. 02696, 02697, 02692, 02694

Wie verwende ich sie?

Come usare?



Komplette Wimper **Ciglio completo**

1. An Ihrem Auge Maß nehmen und den Überschuss abschneiden
2. Tragen Sie eine dünne Linie Kleber entlang des Streifens auf. Zur Anpassung 30 Sekunden warten
3. Mit Hilfe einer Pinzette auf dem Augenlid am Haaransatz der Wimpern anbringen
4. Schminken und fertig!

1. Prendi la misura dell'occhio e taglia la parte in eccesso
2. Applica una sottile linea di adesivo lungo la striscia. Attendi 30 secondi per regolare
3. Con l'aiuto di una pinzetta, posiziona sulla palpebra all'origine delle ciglia
4. Trucca e voilà!

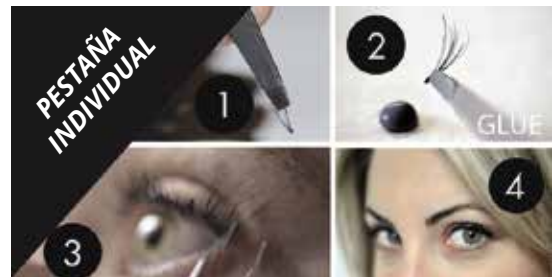

Einzelne Wimper **Ciglia individuali**



1. Wimper mit einer Pinzette aufnehmen
2. Die Basis mit Kleber befeuchten
3. Auf den Haaransatz der Wimpern anbringen. Niemals auf das Augenlid
4. Schminken und fertig!

1. Prendi le ciglia con una pinzetta
2. Bagna la base con l'adesivo
3. Posiziona sulla linea delle ciglia. Mai sulla palpebra
4. Trucca e voilà!

**Für einen natürlichen
und interessanten Look**
Per un look naturale e sofisticato



Pinzette für falsche Wimpern
Pinzette per ciglia finte

u.m.vta: 1  12 

REF.06314

Pinzette zur Anbringung von falschen Wimpern, hilft beim Auftragen der kompletten Wimpern mit mehr Präzision und Hygiene

Pinzette per posizionare le ciglia finte, aiuta a posizionare le ciglia complete con maggiore precisione e igiene



Wimpern ANDREA SM
Ciglia ANDREA SM

u.m.vta: 4  72

62 Schwarz
62 Nere



REF.02700



21 Schwarz
21 Nere



REF.02690



23 Schwarz
23 Nere



REF.02692



28 Schwarz
28 Nere



REF.02694



45 Schwarz
45 Nere



REF.02696



53 Schwarz
53 Nere



REF.02698



70 Schwarz
70 Nere



REF.02701



21 braun
21 Marroni



REF.02691



26 Schwarz
26 Nere



REF.02693



33 Schwarz
33 Nere



REF.02695



45 braun
45 Marroni



REF.02697



53 braun
53 Marroni



REF.02699



Komplette Wimpern selbstklebend schwarz
Ciglia intere autoadesive nere



u.m.vta: 4 72

33 Schwarz
33 Nere
REF.03670



21 Schwarz
21 Nere
REF.03672



45 Schwarz
45 Nere
REF.03673



53 Schwarz
53 Nere
REF.03671



Komplette Wimpern
Full eyelashes

u.m.vta: 4 72

• 52 Schwarz
• 52 Nere

REF.04841



• 33 braun
• 33 Marroni

REF.04079



• 80 Schwarz
• 80 Nere

REF.04842



• 82 Schwarz
• 82 Nere

REF.04843



19 Schwarz
19 Nere

REF.04844



Mod. Accents
318 Schwarz
Mod. Accents
318 nere

REF.04846



Mod. Accents
301 Schwarz
Mod. Accents
301 nere

REF.04554



Mod. Accents
305 Schwarz
Mod. Accents
305 nere

REF.04555



Komplette Wimpern Lashlites 335 schwarz
Ciglia intere Lashlites 335 nere

u.m.vta: 4  72

REF.04845



Kit Wimpern Andrea Starter
Kit ciglia Andrea Starter

u.m.vta: 4  36

Starter 45
Starter 45

REF.02704



Starter 53
Starter 53

REF.02703



Starter 33
Starter 33

REF.02702



Strähne Wimpern ohne Knoten
Ciuffi di ciglia senza nodi

u.m.vta: 4  72

Lang
Lunghe



REF.04553



Mittellang
Medie



REF.04552



Kurz
Corte



REF.04551



Vorher . Prima

Nachher . Dopo



Kit Einzelne Wimpern Permalash Ciglia individuali Permalash, ciuffi

u.m.vta: 4  72

Mittellang. Braun SM
Medie. Marroni SM



REF.02708



Combo. Schwarz
Combo. Nere



REF.03278



Mittellang
Schwarz SM
Medie. Nere SM



REF.02707



Lang. Schwarz
Lunghe. Nere



REF.04078



Klein. Schwarz SM
Piccol2. Nere SM



REF.02705



Klein, Braun SM
Piccole, Marroni SM



REF.02706



Mittellang, Haar für Haar,
schwarz
Medie nere, peli singoli



REF.03277



Kurz, Haar für Haar,
schwarz
Corte nere, peli singoli



REF.03276



Kit Einzelne Wimpern Combo schwarz Kit ciglia singole combo nere

u.m.vta: 4  36

REF.04077



Kleber für einzelne Wimpern

Adesivo per ciglia individuali

Nicht geeignet für volle Wimpern
Non adatto per ciglia piene

u.m.vta: 6  72

Andrea Permalash **hell** transparent
Andrea Permalash **Chiaro** trasparente

REF.02713

3,5 g



Andrea Permalash **dunkel**
Andrea Permalash **Scuro**

REF.03066

3,5 g



Lösungsmittel für Kleber für EINZELNE Wimpern

Solvente per ciglia adese SINGOLE

u.m.vta: 6  72

REF.03204

3,5 g



Kleber für KOMPLETTE Wimpern

Adesivo per ciglia INTERE

Nicht für Einzelwimpern geeignet
Non adatto per ciglia singole

u.m.vta: 6  72

Andrea Permalash **hell** transparent
Andrea Permalash **Chiaro** trasparente

REF.02711

3,5 g



Andrea Permalash **dunkel**
Andrea Permalash **Scuro**

REF.02712

3,5 g



Verkaufsträger Wimpern Andrea Espositore per ciglia Andrea

u.m.vta: 1  1

REF.03203



Drehbarer
Verkaufsträger
Espositore rotante

u.m.vta: 1  1

REF.03335



Drehbarer
Verkaufsträger
Espositore rotante



Enthält je 8 Stück:

- Komplette Wimpern: 02690, 02691, 02693, 02695, 02696, 02698, 02700, 02701
- Kleber für komplette Wimpern: 02711 (hell), 02712 (dunkel)
- Einzelne Wimpern: 02705, 02706, 2707, 02708, 03278
- Kleber für einzelne Wimpern:
• 02713 (hell), 03066 (dunkel)
- Lösungsmittel für Kleber für einzelne Wimpern: 03204

Verkaufsträger für Wimpern Andrea LEER
Espositore per ciglia Andrea VUOTO

- Contiene 8 unità di ciascuna:
- Ciglia intere: 02690, 02691, 02693, 02695, 02696, 02698, 02700, 02701
- Adesivo per ciglia intere: 02711 (chiaro), 02712 (scuro)
- Ciglia individuali: 02705, 02706, 2707, 02708, 03278
- Adesivo per ciglia individuali:
• 02713 (chiaro), 03066 (scuro)
- Solvente per ciglia adesive singole: 03204

Wimpern-Curler Piegaciglia

u.m.vta: 12  120

REF.01109

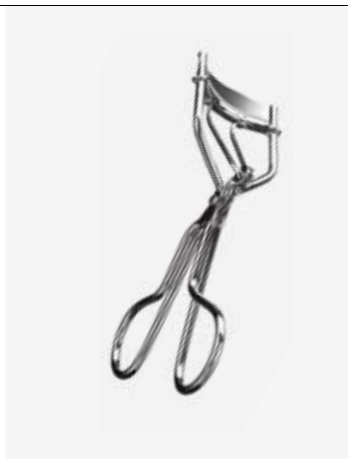

Ersatzgummi Wimpern-Curler Ricambio in gomma per piegaciglia



u.m.vta: 12  12

2 u

REF.01110



3 Rasiermesser pollié für augenbrauen 3 Raso pollié per sopracciglia

u.m.vta: 1	 12	
------------	--	---

Rasierklinge für Augenbrauen, Gesichts- und Körperbehaarung. Für einen sanfteren und komfortableren Schnitt raten wir, das Gel oder die Creme in dem Bereich aufzutragen, den man rasieren möchte. Der Griff ist aus ABS hergestellt, während die Klinge aus hochwertigem Edelstahl ist.

Rasoio per sopracciglia, peli del viso e del corpo. Si consiglia di applicare gel o crema nella zona da rasare, in modo che il taglio sia più morbido e confortevole. Il manico è in ABS mentre la lametta è in acciaio inossidabile di alta qualità.

REF.07125



REF.07126



Augenbrauen Andrea Sopracciglia Andrea

u.m.vta: 1	 24
------------	--

3 in 1 Creme mittelbraun
3 in 1 crema marrone medio

REF.06286



Pulver Duo mittelbraun
Cipria duo marrone medio

REF.06287



Pulver Duo dunkelbraun
Cipria duo marrone scuro

REF.06288



Stift Duo dunkelbraun
Pencil duo marrone scuro

REF.06289





07

Accessoires und hygiene Accessori e igiene

Abdeckungen und Papier für Kosmetikstühle,
Handtücher, Laken, Spiegel, Kleidung, Koffer...

Fodere e carta coprilettino, asciugamani, lenzuola,
specchi, guardaroba, valigie...

Tasche 10 Verstellbare Abdeckung Kosmetikstuhl Confezione da 10 fodere adattabili per lettino

u.m.vta: 1  10 

30 g



REF.07308

- Material: Vliesstoff
- Abmessungen: 210 cm x 80 cm
- Box 100 Stück Abdeckungen für Kosmetikstuhl, an den Enden verstellbar
- In einzeltem Beutel geliefert
- Gewicht: 30 g

- *Materiale: Tessuto non tessuto*
- *Dimensioni: 210 cm x 80 cm*
- *Scatola da 100 unità copri lettino regolabili alle estremità*
- *Presentato in sacchetto individuale*
- *Peso: 30 g*



Rolle Papier für Kosmetikstuhl Rotolo di carta copriletino

u.m.vta: 6  6 



REF. 00928

- Länge: 78 m / Breite: 59 cm
- Papiergewicht: 43 g
- 40 markierte und vorgeschnittene Teile von je 1,95 m Länge
- Die Rollen sind einzeln verpackt

- *Lunghezza: 78 m / larghezza: 59 cm*
- *Grammatura carta: 43 g*
- *40 servizi segnati e pretagliati, ciascuno lungo 1,95 m*
- *I rotoli sono confezionati singolarmente*





REF.00928/75

43 g



Rolle Papier für Kosmetikstuhl superbreit Rotolo di carta lettino extra larga

u.m.vta: 6  6 

REF. 03336

- Super Breite; 78 cm
- 40 markierte und vorgeschnittene Teile von je 1,95 m Länge
- Die Rollen sind einzeln verpackt

- *Extra larga: 78 cm*
- *40 servizi segnati e pretagliati, ciascuno lungo 1,95 m*
- *I rotoli sono confezionati singolarmente*

43 g



Heizdecke für Kosmetikstühle Coperta elettrica per lettini

u.m.vta: 1  4

90 g

REF. 07791





30 Einweglaken 30 lenzuola antisudore

u.m.vta: 1  10

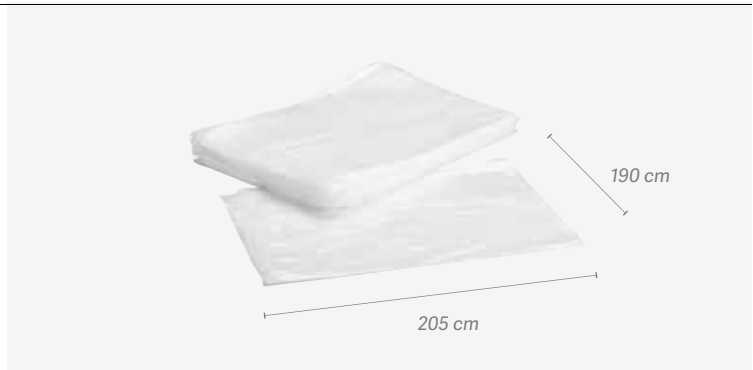
REF. 03912





Abdeckung Kosmetikstuhl Tergal weiß Fodera coprilettino tergale bianca

u.m.vta: 1  12 

REF. 06650



Beutel mit 75 Handtüchern ZELLULOSE
Confezione da 75 salviette CELLULOSA

u.m.vta: 1  16 

Spezial Maniküre
 Speciale per manicure

REF. 04204

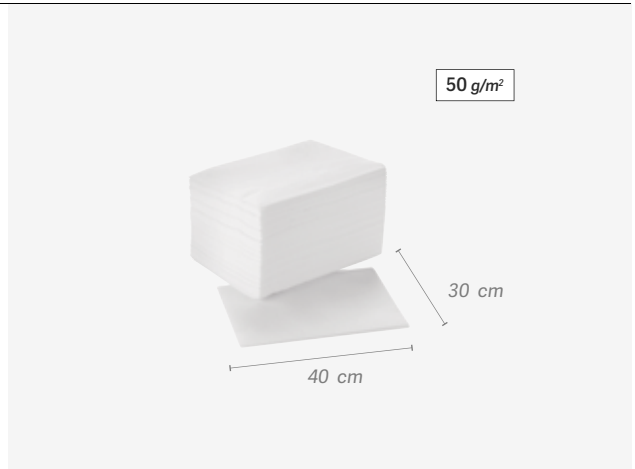

Beutel mit 90 Handtüchern ZELLULOSE
Confezione da 90 salviette CELLULOSA

u.m.vta: 4  144 

REF.04076

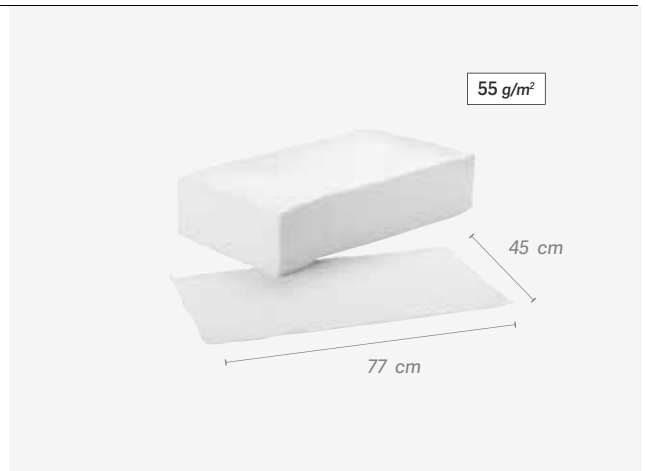

35 Handtücher SPUNLACE
Confezione da 35 asciugamani SPUNLACE

u.m.vta: 1  12 

50 g/m²



REF. 04509

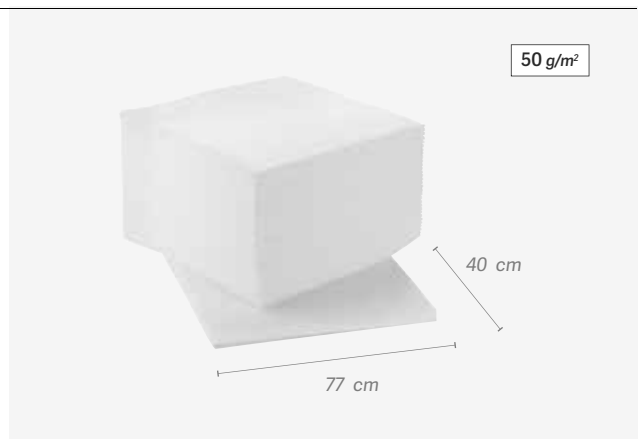

- Handtücher gefaltet
- Spezial für Maniküre
- Ultra assorbenti
- Salviette piegate
- Speciale per manicure



Beutel mit 25 Handtüchern SPUNLACE

Confezione da 25 salviette SPUNLACE

u.m.vta: 1  24 

u.m.vta: 1  28 

50 g/m²

40 x 90 cm

REF. 04916

50 g/m²

40 x 80 cm

REF. 03221

50 g/m²





- Gefaltet auf 20 x 20 cm
- 50% Polyester / 50% Viskose

- Piegate 20 x 20 cm
- 50% poliestere / 50% viscosa

Beutel 100 Handtücher SPUNLACE

Confezione da 100 salviette SPUNLACE



u.m.vta: 1  16 

50 g/m²

REF. 07302

- Zusammensetzung: 50% viskose / 50% polyester.
- Äusserst praktisches, strapazierfähiges und saugfähiges produkt für den vielseitigen einmalgebrauch:
- Vollkommen weich und frei von latex

- *Composizione: 50% viscosa / 50% poliestere.*
- *Prodotto altamente resistente e assorbente, versatile, pratico e usa e getta*
- *Completamente privo di lattice, extra morbido al tatto*



u.m.vta: 1  32 

50 g/m²

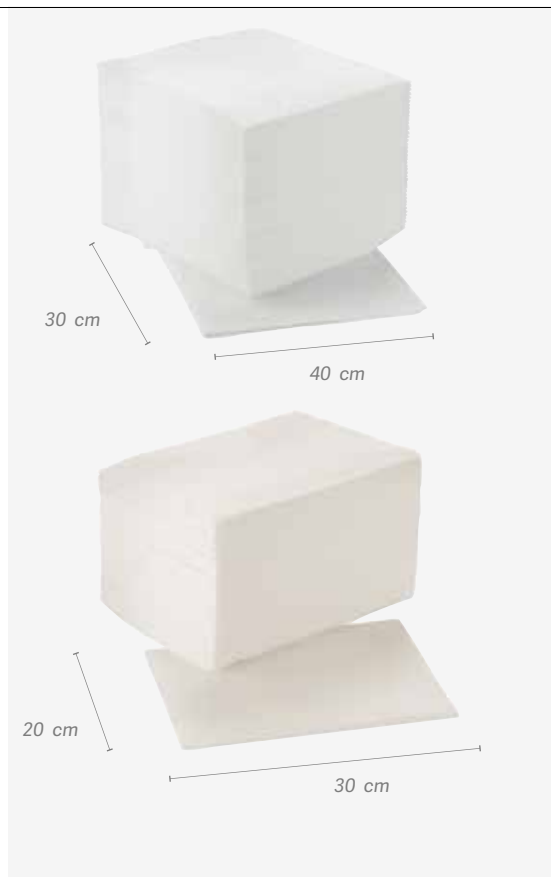
REF. 07303



Beutel 75 Handtücher SPUNLACE Confezione da 75 salviette SPUNLACE



u.m.vta: 1  16 

REF. 04510

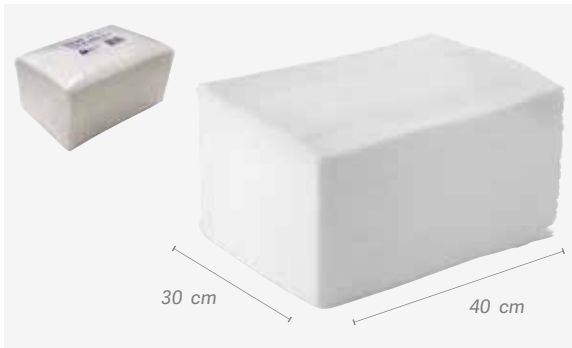
- Super-absorbierend
- Handtücher gefaltet
- Spezial für Maniküre
- Ultra assorbenti
- Salviette piegate
- Speciale per manicure



Beutel mit 100 Handtüchern SPUNLACE Confezione da 100 salviette SPUNLACE



u.m.vta: 1  20 

REF. 03283

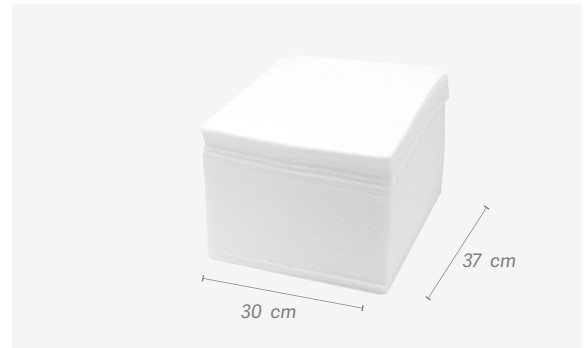
- Super-absorbierend
- Ultra assorbenti



Schutzhose Protezioni - pantaloni

u.m.vta: 1  10 

REF. 06111

Schutzhose aus Polyethylen von hoher Dichte für Schönheitsbehandlungen wie Pressotherapie oder Behandlungen in der Kabine mit Algen oder Fango. Beutel mit 25 Stück.

Pantalone protettivo in polietilene ad alta densità per trattamenti estetici come pressoterapia o trattamenti in cabina con alghe o fanghi. Confezione da 25 unità.



100 transparente Polyethylenhandschuhe 100 Guanti polietilene trasparenti



u.m.vta: 100  100

REF. 07804

- 100% jungfräuliches Polyethylen hdpe 0,7 +/- 2% g / Stk
- Hypoallergen, wasserdicht, Einheitsgröße
- PSA Kategorie 1
- Hergestellt und CE-gekennzeichnet, kompatibel mit Lebensmitteln 2011/10 / CE
- 30 cm. Höhe x 25 cm. Fingerbreite x 15 cm. Handgelenkbreite
- Polietilene hdpe 100% 0,7 +/- 2% g / pz
- Anallergici, impermeabile, taglia unica,
- DPI di categoria 1, prodotti e marcati CE,
- Compatibile con uso alimentare 2011/10 / CE
- 30 Cm altezza x 25 cm larghezza x 15 larghezza polso 15



100 Handschuhe einmaligen Gebrauch 100 Guanti monouso

u.m.vta: 1  25 

80 g

REF. 07257

- Mit beidhändig kann jeder Handschuh für jede Hand verwendet werden
- Einheitsgröße
- Mehrzweck
- *Ambidestro consente a ciascun guanto di essere usato per qualsiasi mano*
- *Taglia unica*
- *Multiuso*



100 HANDSCHUHE PE zum einmaligen Gebrauch und für eine astreine Hygiene 100 Guanti pe monouso

u.m.vta: 1  1



REF.00680

Material: niederdruck-LDPE-polyethylen-kunststoff
Eigenschaften: glatt, farblos
Grösse: gross beihändig

Materiale: plastica polietilene LDPE a bassa pressione
Caratteristiche: liscio, incolore
Dimensione: grande ambidestro



Beutel mit 100 Einweghandschuhen Confezione da 100 guanti monouso

u.m.vta: 1  100 

REF. 07304



Beutel 2 Stück professionelle Handschuhe Confezione da 2 unità guanti professionali

u.m.vta: 1  24

- Material: Kautschuk
- *Materiale: gomma*

6,5
Talla /Size

REF.01672

7
Talle /Size

REF.01673

7,5
Talla /Size

REF.01674

8
Talla /Size



REF.01675



Karton 50 synthetische Handschuhe

Confezione da 50 guanti sintetici

Ohne Pulver
SENZA polvere

u.m.vta: 1  20 

L

REF. 07264

- Verbindet die Flexibilität von Latex und die Elastizität des geruchslosen Vinyls.
- Gefühl einer zweiten Haut, dank ihrer elastischen Eigenschaften, sehr ähnlich wie beim Latex, und bietet die hypoallergenen Eigenschaften des Vinyls.
- Material: PVC-Derivat.
- Nicht steril
- Farbe schwarz
- Innen- und Außenoberfläche glatt
- Geeignet für Latex-Allergiker

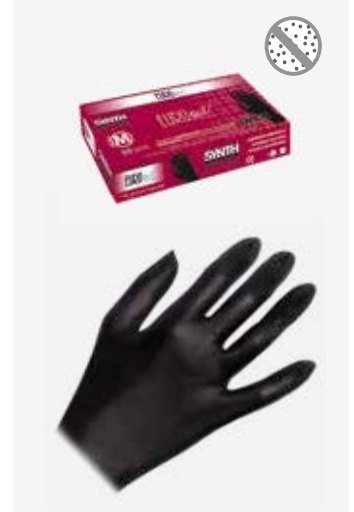

- *Combinano la flessibilità del lattice e l'elasticità del vinile inodore.*
- *Sensazione di seconda pelle grazie alle sue proprietà elastiche molto simili al lattice e alle proprietà ipoallergeniche del vinile.*
- *Materiale: derivato del PVC*
- *Non sterili*
- *Colore nero*
- *Superfici interne ed esterne lisce.*
- *Adatti agli allergici al lattice.*



Schachtel mit 100 weißen Latexhandschuhen mit wenig Puder

Confezione da 100 guanti in latex bianco con poco talco

Ohne Pulver
SENZA polvere

u.m.vta: 1  10 

S

REF. 01671

M

REF. 01669

L

REF. 01670





LATEX / LATEX
AQL 1,5

Schachtel mit 20 schwarzen Latexhandschuhen

Confezione da 20 guanti in latex

Ohne Pulver
SENZA polvere

u.m.vta: 1  24 

S

REF. 02832

M

REF. 02833

L

REF. 02834





LATEX / LATEX
AQL 1,5

Schachtel mit 100 Vinyl-Handschuhen

Confezione da 100 guanti in vinile

Ohne Pulver
SENZA polvere

u.m.vta: 1  10 

S

REF. 02586

M

REF. 02587



VINYL / VINILE
AQL 1,5

Pinzette rostfrei doppelt, allgemeine Verwendung für Utensilien
Pinzette in acciaio inossidabile. Per uso generale

u.m.vta: 1  12

REF.04556



Handtuch 100% Baumwolle
Asciugamano 100% cotone

u.m.vta: 12  48 

 REF. 02947/58

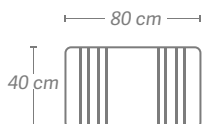

 REF. 02901/58

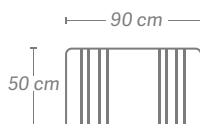

Handtuch Maniküre
Asciugamano per manicure

u.m.vta: 12  48

REF.00974

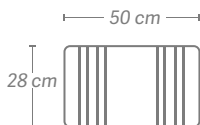



Handtuch 100% Baumwolle
Asciugamano 100% cotone

u.m.vta: 1  12

380 g/m²

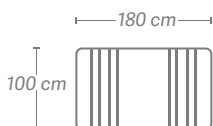
REF. 06570/58



u.m.vta: 1  12

380 g/m²

REF. 06571/58

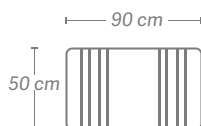

Mehrzweck-Bürste, farbig
Spazzola colorata multiuso

u.m.vta: 24  24

REF. 00129



Bürste für Kleidung und Polstermöbel
Spazzola per abiti e tappezzeria

u.m.vta: 1  20 



REF.00893

Gummi blau
 Gomma blu



Schutzlaken

Lenzuola protettiva



u.m.vta: 1  16 

REF. 06112



Laken aus Polyethylen von hoher Dichte. 25 Stück von 180 x 200 cm. Für Behandlungen mit Algen und Fango

Lenzuola in polietilene ad alta densità. 25 unità da 180 x 200 cm. Per trattamenti con alghe e fanghi

u.m.vta: 1  10 

REF. 06110



Laken aus Polyethylen von hoher Dichte. 50 Stück von 180 x 200 cm. Für Behandlungen mit Algen und Fango

Lenzuola in polietilene ad alta densità. 50 unità da 180 x 200 cm. Per trattamenti con alghe e fanghi

Spa-Waage, misst die Hydratation und den Anteil an Körperfett

La bilancia spa misura l'idratazione e la percentuale di massa grassa

u.m.vta: 1  6 

REF. 04805



- Fassungsvermögen: 150 kg
- Skala: 6 bis 150 kg
- Gewichtseinheiten: kg / lb / st
- Zwei Batterien CR2032 (mitgeliefert)
- Wiegeschwindigkeit: mittlere Geschwindigkeit etwa zwei Sekunden
- Automatische Abschaltung: 10 Sekunden
- Wenn der Batteriestand niedrig ist, erscheint am Bildschirm "LO"

- Capacità: 150 kg
- Scala: Da 6 a 150 kg
- Unità di peso: kg / lb / st
- Due batterie CR2032 (incluse)
- Velocità di pesatura: velocità media (circa due secondi)
- Spegnimento automatico: 10 secondi
- Quando la batteria è scarica, sullo schermo verrà visualizzato "LO".



Fußmatten Solarium

Tappetini per solarium

u.m.vta: 1  20 

Beutel 50 Fußmatten für Solarium
Confezione da 50 tappetini per solarium

REF.03803



Beutel mit 10 Einweg-Kimonos

Confezione da 10 Kimono monouso

u.m.vta: 1



10



28 g

REF. 07307/58



28 g

REF. 07307/50



- Maße: 104 x 140 cm
- Material: Vliesstoff (ungeflochtenes Gewebe)
- Der Gürtel befindet sich in einer Tasche des linken Arms
- Beutel mit 10 Einheiten

- Misure: 104 x 140 cm
- Materiale: tessuto non tessuto
- La cintura si trova in una tasca del braccio sinistro
- Confezione da 10 unità

Beutel 100 schuh-überzüge

Fodera copriscarpe da 100 unità

u.m.vta: 1



50

REF.07211

- Einweg
- Plastik
- Monouso
- Plastico
- Geschlossen
- Einmaliger Gebrauch
- Chiuse
- Monouso



Beutel mit 100 Schuhen mit Gummisohle
Confezione da 100 ciabattine con suola in gomma

u.m.vta: 100  100

Offen
 Aperte

REF.02919



Geschlossen
 Chiuse

REF.02920



Beutel mit 50 Schuhen
Confezione da 50 ciabattine

u.m.vta: 1  10



REF.03807



REF.03808



Paar zwei Pediküre-Hausschuhe
Paio di due ciabatte da pedicure



u.m.vta: 1  12 

REF. 06776

- Verschiedene Farben
- Assortimento di colori



Tasche mit 12 Paar Pediküre-Hausschuhe
Confezione da 12 paia di ciabatte da pedicure



u.m.vta: 1  40 

REF. 07432



Beutel 100 Hauben

Confezione da 100 cuffie

u.m.vta: 1  10 



10 g

REF.07305

- Einmaliger Gebrauch
- Gefaltet nach Art eines Akkordeons
- *Monouso*
- *Piega a fisarmonica*

Box 100 Diademe weiß

Confezione da 100 fascette bianche

u.m.vta: 1  10 **REF.07306**

- Einmaliger Gebrauch
- *Monouso*



Rolle Krepp-Papier

Rotolo di carta crepe

u.m.vta: 5  100**REF.04420**



- Für Diademe
- 100 Teile
- Spezial Schönheitspflege
- Farbe rosa

- *Per fasce*
- *100 servizi*
- *Speciale estetica*
- *Colore rosa*



Beutel 50 Tangas Herren

Confezione da 50 tanga da uomo

u.m.vta: 1  20 

REF.03216

- Einmaliger Gebrauch
- Einheitliche Größe
- Gummi zur Anpassung an alle Maße
- Farbe mattschwarz
- Ideal als Ergänzung zur Haarentfernung und Haarbehandlung
- *Monouso*
- *Taglia unica*
- *Elastico per adattarsi a qualsiasi taglia*
- *Colore nero opaco*
- *Ideale come complemento per depilazione e trattamenti*



Beutel 50 Slips Herren

Confezione da 50 slip da uomo

u.m.vta: 1  10

REF.03295

- Einmaliger Gebrauch
- Einheitliche Größe
- Elastische zur Anpassung an jedes Maß
- Farbe mattblau
- Ideal als Ergänzung zur Haarentfernung und Behandlung
- *Monouso*
- *Taglia unica*
- *Elastico per adattarsi a qualsiasi taglia*
- *Colore blu opaco*
- *Ideale come complemento per depilazione e trattamenti*



Beutel 10 Boxershorts Herren

Confezione da 10 boxer da uomo

u.m.vta: 1  4

REF.03802

- Einmaliger Gebrauch
- *Monouso*



Beutel 100 Tangas Typ Steinschleuder Damen

Confezione da 100 tanga da donna

u.m.vta: 1  12

REF.03483

- Gummi zur Anpassung an alle Maße
- Einmaliger Gebrauch
- Breiter Riemen
- *Elastico per adattarsi a qualsiasi taglia*
- *Monouso*
- *Cinturino largo*



Beutel 100 String-Tangas Damen

Confezione da 100 tanga da donna in tessuto

u.m.vta: 1  12



REF.01091

- Sehr enges hinteres Band
- Einmaliger Gebrauch
- *Filo posteriore molto fine*
- *Monouso*



Hose Pressotherapie Kunststoff

Pantaloni per pressoterapia in plastica

u.m.vta: 1  100 

REF.03694



- Ohne Gummi
- Farbe weiß
- Einmaliger Gebrauch

- Senza elastico
- Colore bianco
- Monouso

Diadem Schönheitspflege

Fascia per estetista

u.m.vta: 10  100

REF. 01088



T-Shirt TASSEL

Maglietta TASSEL

u.m.vta: 1  50

M

REF.06284/2

L

REF.06284/3

XL

REF.06284/4

XXL

REF.06284/5



Damen-T-Shirts aus Baumwolle. Farbe schwarz, Rundkragen und kurze Ärmel mit dem Logo Tassel als Siebdruck auf der Brust. Verfügbar in mehreren Größen. Bequem, leicht zu kombinieren mit jedem Look. Widerstandsfähiges Gewebe.

Magliette da donna in cotone. Colore nero, girocollo e maniche corte con logo Tassel serigrafato sul petto. Disponibili in varie misure. Comode, facili da abbinare a qualsiasi look. Tessuto resistente.

Anti-fog-schutzbrille

Occhiali protettivi antivapore

u.m.vta: 1  10

REF.07256



- Schutz zur Prävention gegen Infektionen: schützt wirksam gegen Spritzer, Kies usw.
- Verwendungsort: jeder Ort, an dem Augenschutz erforderlich ist.
- Innovatives, komfortables Design. Passt sich perfekt an jede Kopfform und Kopfgröße an.
- Kann gleichzeitig mit Ihrer normalen Brille verwendet werden.
- EG-Zertifizierung
- Material: Kunststoff

- Protezione per prevenire le infezioni: proteggere efficacemente da schizzi, schegge, ecc.
- Luogo di utilizzo: qualsiasi luogo in cui è richiesta la protezione degli occhi.
- Confortevole design innovativo. Si adattano perfettamente a qualsiasi forma e dimensione della testa.
- Possono essere utilizzati contemporaneamente agli occhiali da vista.
- Certificato CE.
- Materiale: plastica

Desinfizierende fussmatte

Tappetino disinfettante per calzature

u.m.vta: 1  12

REF.07234



Extra flache Fußmatte mit nur 1 cm Höhe zur Verhinderung von Ausrutschern, hergestellt aus Polypropylen auf einer Gummiunterlage, enthält ionisiertes Aluminium. Maße: 60 cm Breite x 40 cm Länge x 1 cm Höhe/Dicke.

Verwendung: die Matte auf eine ebene, waagerechte Fläche legen, etwa 700 ml Desinfektionsflüssigkeit auf die Ablage auftragen. Es ist ratsam, einen Fußabtreter auf die Ablage zu legen, um die Schuhe des Kunden zu trocknen.

Tappetino extra piatto alto solo 1 cm per evitare inciampi, realizzato in polipropilene su base in gomma e contenitore in alluminio ionizzato. Misure: 60 cm di larghezza x 40 cm di lunghezza x 1 cm di altezza/spessore.

Modo d'uso: posizionare il tappetino su una superficie piana e livellata, applicare circa 700ml di liquido disinfettante sul vassoio. Si consiglia di posizionare un tappetino accanto al vassoio per asciugare le scarpe del cliente.

Box 200 wattestäbchen mit PAPIERSCHAFT

Confezione da 200 cotton fioc con BASTONCINO DI CARTA

u.m.vta: 1  24

REF.07261



Beutel Watte „zick-zack“, vorgeschritten

Sacchetto cotone zigzag pretagliato

u.m.vta: 20  20









REF.02949



Beutel mit 1 kg Baumwolle in Rollen

Confezione da 1 kg di cotone in rotoli

Spitzen inbegriffen
Fermagli inclusi

u.m.vta: 1	 12		u.m.vta: 1	 12		u.m.vta: 1	 12		u.m.vta: 1	 10	
------------	--	---	------------	--	---	------------	--	---	------------	--	---

REF. 00964

Anonym
Senza marca

REF. 00964/00

4 Schnitte von 8 cm
4 tagli da 8 cm

REF. 04290



Gefaltet
Piegato

REF. 04288



Beutel Abschminkscheiben



Sacchetto dischi struccanti

u.m.vta: 24	 24	
-------------	--	---

80 Scheiben
80 dischi

REF. 07118





u.m.vta: 1	 24	
------------	--	---

Anonym
Senza marca

REF. 07118/00





Runder Spiegel, verchromt
Specchio tondo cromato

u.m.vta: 1  60  Ø 10 cm



<input type="text" value="5x"/>	<input type="text" value="7x"/>	<input type="text" value="10x"/>
REF.06716	REF.06717	REF.06718



u.m.vta: 1  24  Ø 15 cm





<input type="text" value="5x"/>	<input type="text" value="7x"/>	<input type="text" value="10x"/>
REF.06719	REF.06720	REF.06721



u.m.vta: 1  24  Ø 18 cm

<input type="text" value="5x"/>	<input type="text" value="7x"/>	<input type="text" value="10x"/>
REF.06722	REF.06723	REF.06724

Runder Spiegel, verchromt mit 3 Saugnäpfen
Specchio tondo cromato con 3 ventose

u.m.vta: 1  48  Ø 15 cm u.m.vta: 1  24 

<input type="text" value="5x"/>	<input type="text" value="7x"/>	<input type="text" value="10x"/>
REF.06725	REF.06726	REF.06727



u.m.vta: 1  24  Ø 21 cm

<input type="text" value="5x"/>	<input type="text" value="7x"/>	<input type="text" value="10x"/>
REF.06728	REF.06729	REF.06730



Runder Spiegel, verchromt mit Basis

Specchio tondo cromato con base

u.m.vta: 1	12		u.m.vta: 1	6	
Ø 15 cm			Ø 21 cm		
7x	10x		7x	10x	
REF.06731	REF.06732		REF.06735	REF.06736	



Gebläuter Spiegel mit Sockel

Specchio azzurrato con base

u.m.vta: 1	12		u.m.vta: 1	6	
Ø 15 cm			Ø 21 cm		
7x	10x		7x	10x	
REF.06733	REF.06734		REF.06737	REF.06738	



Runder Spiegel, verchromt mit Fuß und Basis

Specchio tondo cromato con asta e base

u.m.vta: 1	12		u.m.vta: 1	6	
Ø 15 cm			Ø 21 cm		
7x	10x		7x	10x	
REF.06739	REF.06740		REF.06741	REF.06742	



Spiegel mit doppeltem Metallfuß 5 Vergrößerung / normal
Specchio con piede in metallo 5x / normale

Verbessertes Produkt - Neue Verpackung
 Prodotto migliorato - Nuova confezione

u.m.vta: 1  6

5x
REF.02801



5x
REF.02806



Verbessertes Produkt - Neue Verpackung
 Prodotto migliorato - Nuova confezione

u.m.vta: 1  12



5x
REF.02799



5x
REF.02800



Doppelspiegel Specchio doppio



u.m.vta: 1  24 

Griff und Ständer
Manico e supporto

REF. 01965



Runder Spiegel Specchio tondo

u.m.vta: 1  8 

Professionell
Professionale

REF. 00294/56

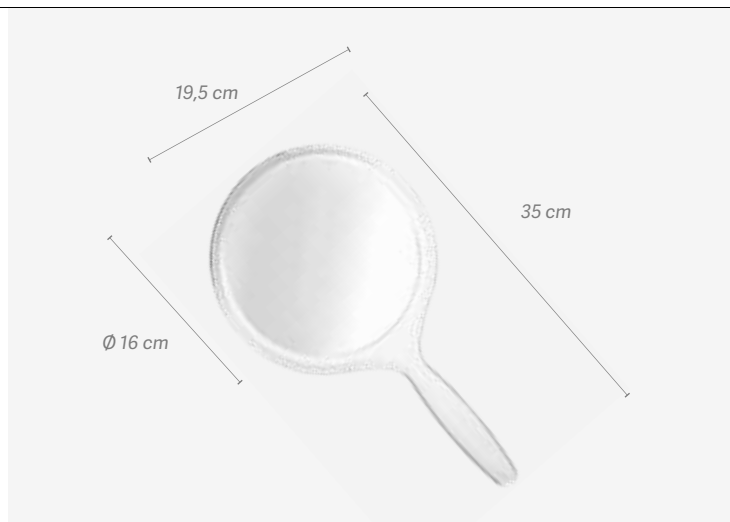



Spiegel Schaum EVA Specchio Gomma EVA

u.m.vta: 1  24

REF.04742





**Spiegel
Specchi**

u.m.vta: 1		75	
------------	---	----	---

Modell Capilla
Richiudibile

REF. 00265

u.m.vta: 1		75	
------------	---	----	---



Quadratisch
Quadrato

REF. 00268

u.m.vta: 1		80	
------------	---	----	--

Quadratisch mit Griff
Quadrato con manico



REF.00250

u.m.vta: 1		30	
------------	---	----	---

REF. 00266

- Runder Spiegel
- Normal/Vergrößerung

- Specchio tondo
- Normale/Aumento

u.m.vta: 1		125	
------------	---	-----	---



REF. 03073

- Spiegel Puderdose
- Normal/Vergrößerung
- Mit Kamm

- Specchio compatto
- Normale/Ingranditore
- Con pettine





Runder Spiegel Specchio tondo

u.m.vta: 1  100 

S

REF. 00263

Runder Spiegel Specchio tondo

u.m.vta: 1  12 

NORMAL/X2 S

REF. 06620

NORMAL/X2 M

REF. 06621

NORMAL/X2 L

REF. 06622

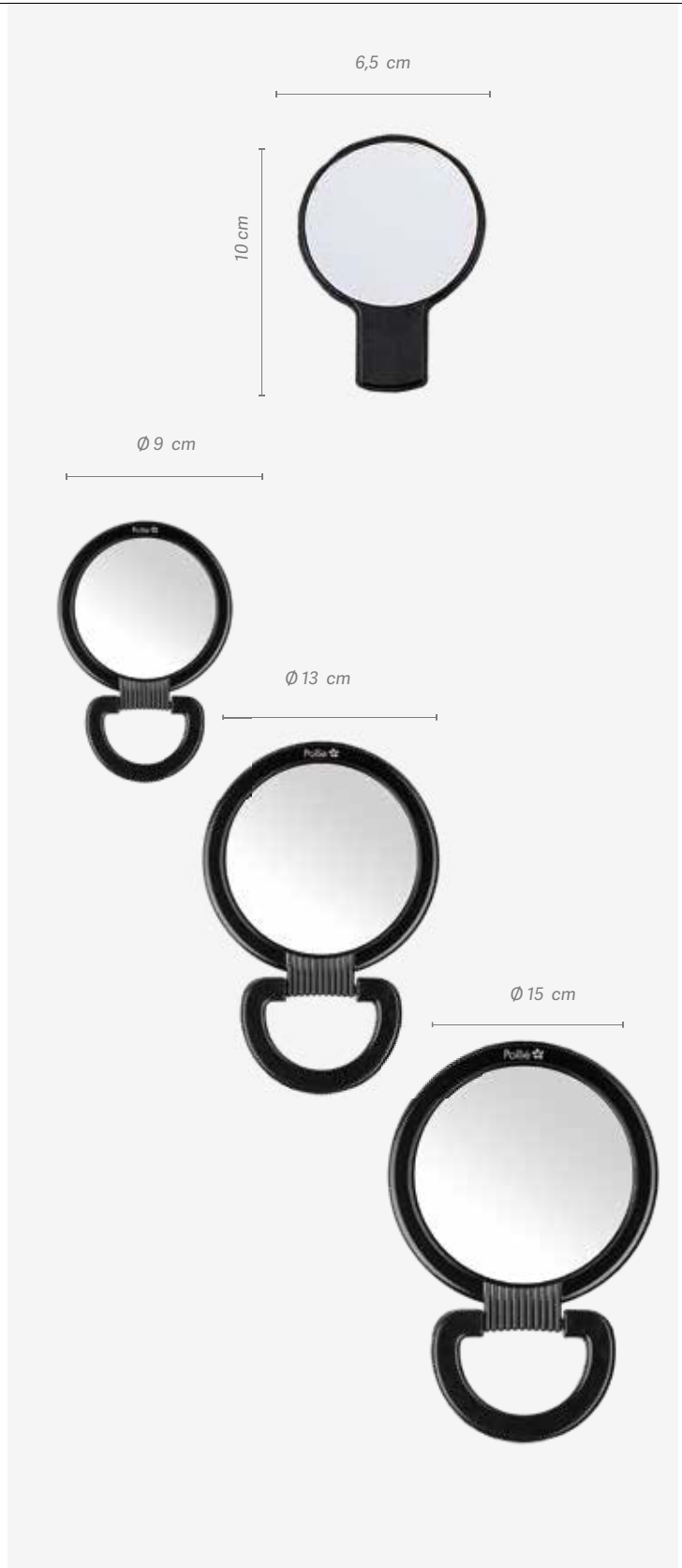

Campingspiegel
Specchio da campeggio

u.m.vta: 1  12

REF.00275

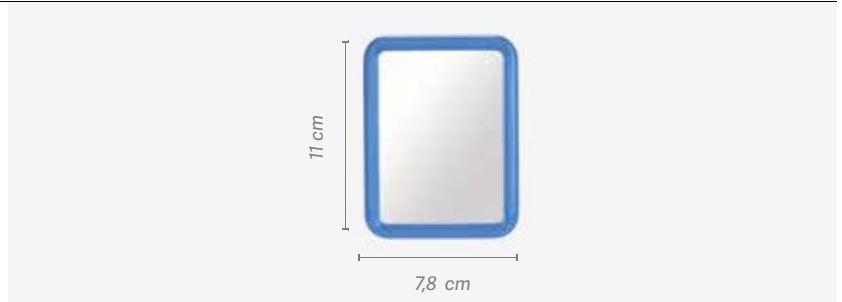

u.m.vta: 12  12

S

REF.00256

M



REF.00257

L

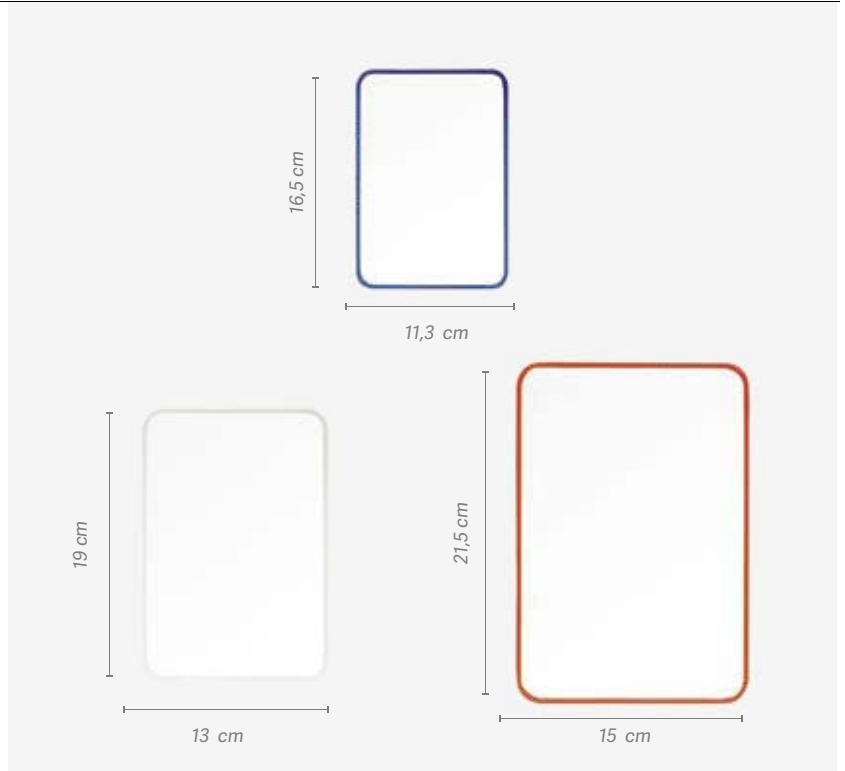
REF.00258



Fernsehspiegel
Specchio TV

u.m.vta: 1  10 

REF. 00254/50



 **REF. 00254/58**

 **REF. 00255**



Schachtel mit 50 hygienischen Gesichtsmasken

Confezione da 50 maschere facciali igieniche

u.m.vta: 1  1 

REF. 07383



Hygienemaske 100% BAUMWOLLE ECOLOGICO 30 mal wiederverwendbar /waschbar

Maschera igienica 100% COTONE ECOLOGICO 30 usi riutilizzabile /lavabile

u.m.vta: 1  36



REF. 07803

- 30 mal verwendbar
- WASCHBAR: Bei 60° waschen, trocknen und 10-15 Sekunden lang bei 140° bügeln, um die Behandlung zu aktivieren. (30 Waschvorgänge)
- 30 servizi
- LAVABILE: Lavare a 60°, asciugare e stirare a 140° per 10-15 secondi per attivare il trattamento. (N. lavaggi 30)



Gesichtsschutzschirm

Schermo protettivo per il viso

u.m.vta: 12  120 

REF. 07212

ANTI-FOG
Transparenter Kunststoff mit Schaumstoff auf der Vorderseite für mehr Komfort

ANTI-APPANNAMENTO
Plastica trasparente con gommapiuma sulla fronte per un maggior comfort

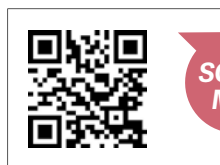
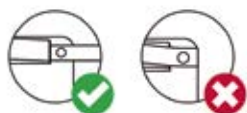
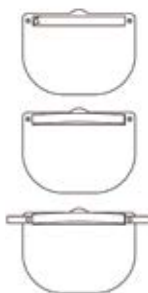

SCAN ME!



**Wiederverwendbare maske,
60 waschvorgänge
Mascherina riutilizzabile
60 lavaggi**

- Wiederverwendbar
- Zertifiziert
- Waterproof
- Schwitzfähig
- Mikrofaser
- Entspricht FFP-2
- LACLA Made in Spain

- Riutilizzabili
- Certificate
- Waterproof
- Traspiranti
- Microfibra
- Equivalenza FFP-2
- LACLA Made in Spain

**Packs 6 stoffmasken einheiten einfarbig
Confezioni 6 mascherine tinta unita**

u.m.vta: 1  20

Rosa
Rosa

REF. 07310

Beige
Beige

REF. 07318

Weiss
Bianco

REF. 07319



**Packs 3 stoffmasken einheiten bedruckt
Confezioni 3 mascherine stampato**

u.m.vta: 1  40

Schmetterlinge
Farfalle

REF. 07311

Herz
Farfalle

REF. 07312

Totenköpfe
Teschi

REF. 07315

Maulwürfe
Pois

REF. 07314

Militär
Militare

REF. 07313



Gehrock Herzen

Camice con cuori

u.m.vta: 1  40Schwarz
Nero

MOD. 51605128

Gehrock mit Mini-Ärmeln, Brustklammer und Mao-Kragen. Mit einer Vordertasche, einer bedruckten und einer unbedruckte Tasche. Mit farbigen Knöpfen, Kleidungsstück auf Taille gearbeitet mit Klammern und mit seitlichen Öffnungen.
100% Polyester

Camice mini manica con clip sul petto e colletto alla coreana. 1 tasca frontale, 1 tasca color fantasia e un'altra in tinta unita. Chiusura con bottoni colorati, capo aderente con pince e aperture laterali.
100% poliestere

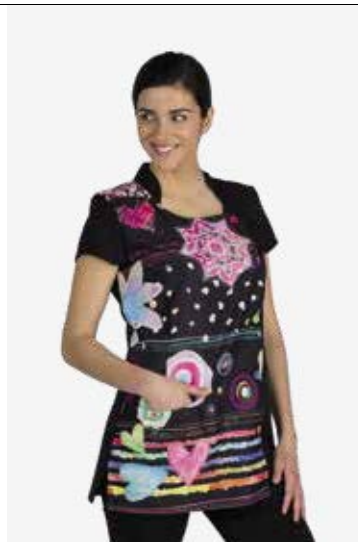
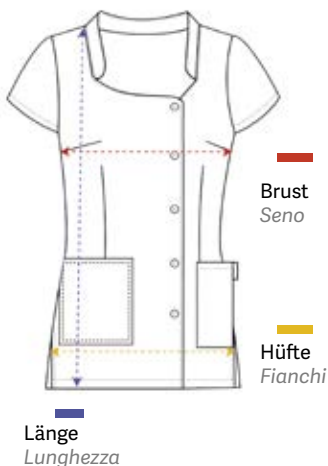

S	M	L	XL	XXL
98 - 102 cm	106 - 110 cm	114 - 118 cm	120 - 124 cm	126 - 130 cm
102 - 106 cm	108 - 112 cm	116 - 120 cm	124 - 128 cm	136 - 140 cm
72 - 74 cm	73 - 75 cm	75 - 77 cm	77 - 79 cm	78 - 80 cm
REF.06297/50/1	REF.06297/50/2	REF.06297/50/3	REF.06297/50/4	REF.06297/50/5

Weiß
Bianco

MOD. 51605128

Gehrock mit Mini-Ärmeln, Brustklammer und Mao-Kragen. Mit einer Vordertasche, einer bedruckten und einer unbedruckte Tasche. Mit farbigen Knöpfen, Kleidungsstück auf Taille gearbeitet mit Klammern und mit seitlichen Öffnungen.
100% Polyester

Camice mini manica con clip sul petto e colletto alla coreana. 1 tasca frontale, 1 tasca color fantasia e un'altra in tinta unita. Chiusura con bottoni colorati, capo aderente con pince e aperture laterali.
100% poliestere

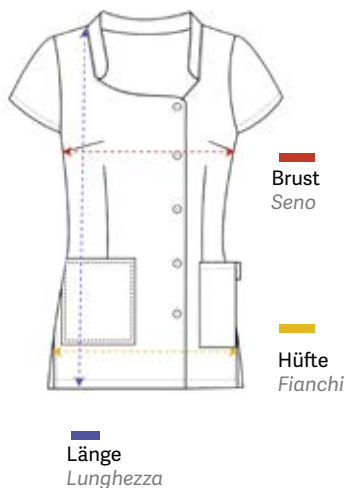

S	M	L	XL	XXL
98 - 102 cm	106 - 110 cm	114 - 118 cm	120 - 124 cm	126 - 130 cm
102 - 106 cm	108 - 112 cm	116 - 120 cm	124 - 128 cm	136 - 140 cm
72 - 74 cm	73 - 75 cm	75 - 77 cm	77 - 79 cm	78 - 80 cm
REF.06297/58/1	REF.06297/58/2	REF.06297/58/3	REF.06297/58/4	REF.06297/58/5

lacla

Gehrock silberner Rand

Camice argento vivo

u.m.vta: 1  40Weiß
Bianco

MOD. 52105640

Einfarbiger Gehrock mit kurzen Ärmeln, Mao-Kragen und Vorderseite mit silberfarbenem Rand aus Satin, Hinterseite mit Laschverstärkungen und Taschen. Mit rechteckigen seitlichen Metallschnallen, Rücken mit Klammern und seitlichen Öffnungen. Leicht zu bügeln. Sehr atmungsaktives Polyester. 100 % feines Polyester

Camice semplice con maniche corte, collo alla coreana, orlo frontale con finiture in satin argento e tasche sui fianchi. Chiusura laterale con fermagli metallici rettangolari, pines sulla parte posteriore e aperture laterali. Facile da stirare. Poliestere molto traspirante. 100 % poliestere fine

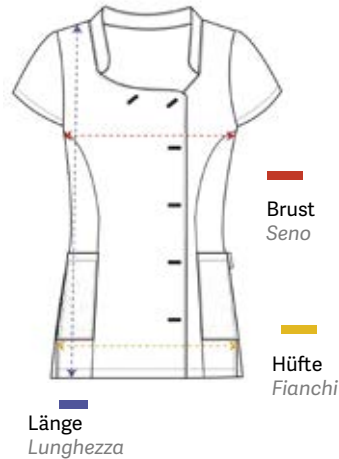
Länge
Lunghezza

S
98 -102 cm
104 -108 cm
70 -72 cm

REF.07552/58/1

M
106 -110 cm
112 -114 cm
70 -72 cm

REF.07552/58/2

L
114 -118 cm
118 -122 cm
72 -74 cm

REF.07552/58/3



MOD. 52105640

Schwarz
Nero

Einfarbiger Gehrock mit kurzen Ärmeln, Mao-Kragen und Vorderseite mit silberfarbenem Rand aus Satin, Hinterteil mit Laschverstärkungen und Taschen. Mit rechteckigen seitlichen Metallschnallen, Rücken mit Klammern und seitlichen Öffnungen. Leicht zu bügeln. Sehr atmungsaktives Polyester. 100 % feines Polyester

Camice semplice con maniche corte, collo alla coreana, orlo frontale con finiture in satin argento e tasche sui fianchi. Chiusura laterale con fermagli metallici rettangolari, pines sulla parte posteriore e aperture laterali. Facile da stirare. Poliestere molto traspirante. 100 % poliestere fine

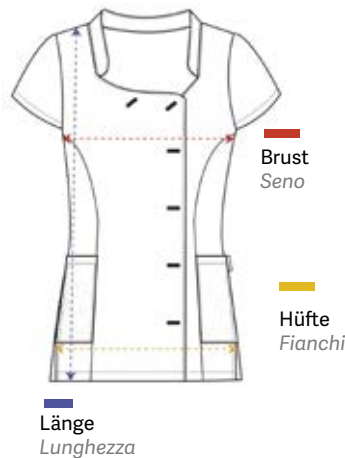
Länge
Lunghezza

S
98 -102 cm
104 -108 cm
70 -72 cm

REF.07552/50/1

M
106 -110 cm
112 -114 cm
70 -72 cm

REF.07552/50/2

L
114 -118 cm
118 -122 cm
72 -74 cm

REF.07552/50/3

XL
120 -124 cm
126 -130 cm
73 -75 cm

REF.07552/50/4



Gehrock Buddha Camice Budda

u.m.vta: 1  40

MOD. 51605109

Japanischer Gehrock, Ärmel mit Rand Ton in Ton, Brustklammer, Mao-Kragen, Vorderteil mit einem Aufdruck, mit lackierten Schnallen und 1 einfache Tasche. Rücken mit Klammern und Binder zum Verstellen der Taille und der seitlichen Öffnungen. Leicht zu bügeln. Atmungsaktives Polyester. 100% Polyester

Camice con maniche giapponesi, laterale nero, clip sul petto, colletto alla coreana, stampa sulla parte frontale, abbottonato con fermagli laccati e 1 tasca nera. Pince sulla schiena, lacci per regolare il girovita e aperture laterali. Facile da stirare. Poliestere traspirante. 100% poliestere

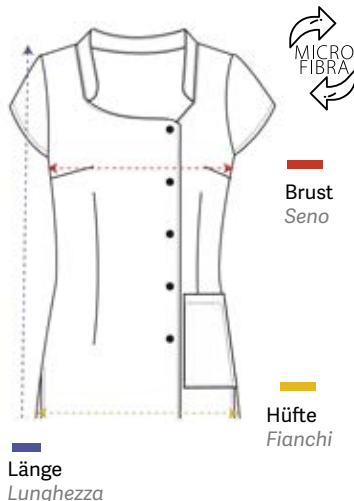

S	M	L	XL	XXL
94 - 98 cm	94 - 98 cm	106 - 110 cm	116 - 120 cm	118 - 122 cm
102 - 106 cm	102 - 106 cm	116 - 120 cm	124 - 128 cm	130 - 134 cm
71 - 73 cm	71 - 73 cm	75 - 77 cm	77 - 79 cm	75 - 77 cm
REF.06300/50/1	REF.06300/50/2	REF.06300/50/3	REF.06300/50/4	REF.06300/50/5

Kimono antistatisch Kimono antistatico

u.m.vta: 1  40

MOD. 21300013 REF.06302/50



UNICA

123 cm
123 cm
104 - 106 cm

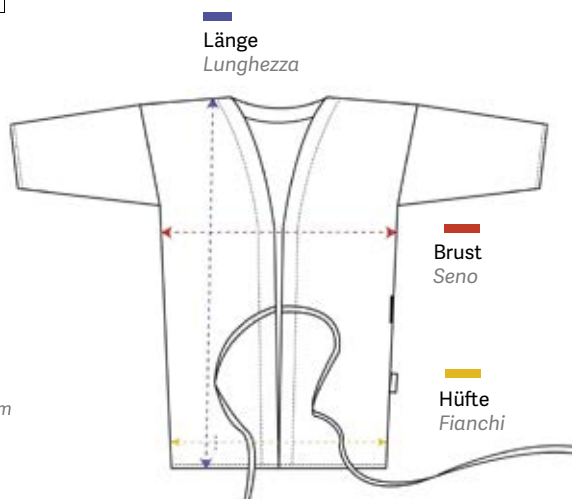

Kimono gekreuzt mit Gürtel und Ärmel 3/4 mit Minitasche am Ärmel. Leicht zu bügeln. Entfärbt nicht. 100% Polyester aus Marokko

Kimono con manica 3/4, cintura e mini tasca sulla manica. Facile da stirare. Non scolora. 100% poliestere marocchino

Einfache Jacke Reißverschluss

Camice basic con zip

u.m.vta: 1 40

MOD. 51308410

Schwarz
Nero

Einfache Jacke ohne Ärmel.
Reißverschluss seitlich.
Zusammensetzung 100% Polyester. Zwei
Taschen, eine an der Taille und die andere
an der Brust. Empfohlen für Geschäfte
und Schönheitszentren

Camice senza maniche basic. Chiusura
con zip sul lato. Materiale: 100%
poliestere. Due tasche, una in vita e una
sul petto. Consigliato per negozi e centri
estetici.

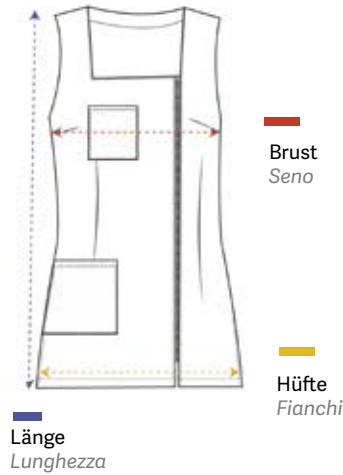

S

88 - 92 cm
100 - 104 cm
69 - 71 cm

REF.06298/50/1

M

94 - 98 cm
104 - 108 cm
71 - 73 cm

REF.06298/50/2

L

102 - 106 cm
110 - 114 cm
73 - 75 cm

REF.06298/50/3

XL

108 - 112 cm
120 - 124 cm
74 - 76 cm

REF.06298/50/4

XXL

116 - 120 cm
128 - 132 cm
76 - 78 cm

REF.06298/50/5

Stola weiß Mod.

Grembiule bianco

u.m.vta: 1 40

MOD. 213014601

REF.06553/58

UNICA

36 cm
51 cm
78 cm

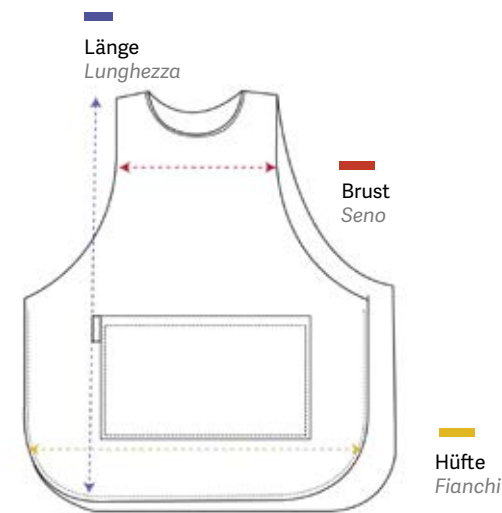

Stola 100% Stretch-Polyester. Einstellung am Rücken mit einer Schlaufe, mit großen und bequemen Vordertaschen
Grembiule elasticizzato 100% poliestere. Regolabile sul dietro con fiocco e dotata di ampie e comode tasche frontali.

Stola Mao-Kragen

Camice con colletto coreano

MOD.21602130

u.m.vta: 1  40

Schürzenkittel mit Mao-Kragen mit Metall-Druckknöpfen, Mini-Ärmeln und Front mit Seitentaschen. Er ist mit Bändern verstellbar, die über den Rücken verlaufen und in der Taille gebunden werden.

Camice con colletto alla coreana con bottoni automatici in metallo, mini maniche, e bottoni e tasche frontali. È regolabile con fasce che attraversano la schiena e annodate in vita.



100% Polyester
100% poliester

REF.06309/50

100% Polyester
100% poliester

REF.06309/63

100% Polyester
100% poliester

REF.06309/68

50% Polyester, 50% Baumwolle
50% poliester, 50% cotone

REF.06309/72



36/37 cm
59/60 cm
75/76 cm





Stola v-ausschnitt

Stola collo a V

u.m.vta: 1 40

MOD. 21602100

REF.07558



- 36 cm
- 51 cm
- 78 cm

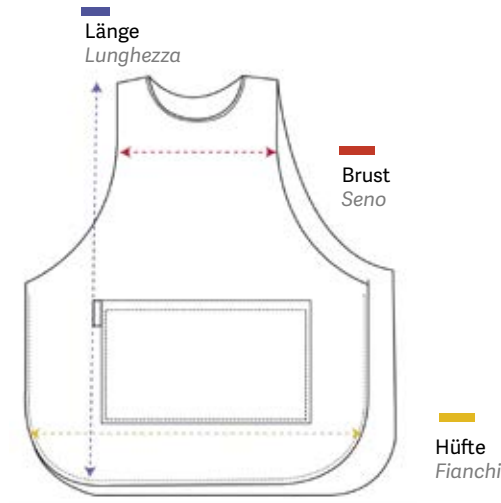

Stola 100% Stretch-Polyester. Einstellung am Rücken mit einer Schlaufe, mit großen und bequemen Vordertaschen
 Grembiule elasticizzato 100% poliestere. Regolabile sul dietro con fiocco e dotata di ampie e comode tasche frontali.

Damenhose

Pantaloni da donna

u.m.vta: 1 40

MOD. 41300011B

- 67% Polyester
- 33% Baumwolle
- 67% poliestere
- 33% cotone



S

- 92-96 cm
- 92-96 cm
- 99-101 cm

REF.06312/58/1

M

- 98-102 cm
- 96-100 cm
- 101-103 cm

REF.06312/58/2

L

- 106-110 cm
- 106-110 cm
- 102-104 cm

REF.06312/58/3



XL

- 112-116 cm
- 114-118 cm
- 105-107 cm

REF.06312/58/4

LED-Ringleuchte 045 cm mit Stativ

Anello luminoso a LED 045 cm con treppiede

u.m.vta: 1  5 

REF. 07003



- Led ring light diameter 18"
- Ring light net gewicht: 1,07 kg
- Ringfarbe: schwarz
- Leistung: 50w
- Spannung: ac100 / 240v
- Stromversorgung: stromkabel
- Led menge: 288 led beads
- Farbtemperatur: 2700k / 5700k
- Led-farbe: pure white / natural white / warm white / cold white
- 2 Usb-ports
- Teile: 1 pc mit 18" led-ringlicht / 3 pc schlauchtelefonhalter / 1 pc fernbedienung
- Bluetooth shutter / 1 pc von 2,5m. Upright tripod stand / 1 tragetasche
- Verpackung: getrenntes ringlicht zusammen verpackt & tripod zusammen verpackt

- *Diametro luce anello led 18"*
- *Peso netto anello leggero: 1,07 kg*
- *Colore anello: nero*
- *Potenza: 50 w.*
- *Tensione: ac100 / 240v*
- *Alimentazione: cavo di alimentazione*
- *Qtà led: 288 perline di led*
- *Temperatura colore: 2700k / 5700k*
- *Colore led: bianco puro / bianco naturale / bianco caldo / bianco freddo*
- *2 Porte usb*
- *Componenti: 1 pezzo di anello di luce a led da 18" / 3 pezzi di portacellulari / 1 telecomando*
- *Otturatore bluetooth / 1 pz da 2,5m. Supporto per treppiede verticale / 1 borsa da trasporto*
- *Confezione: anello di luce separato imballato insieme e treppiede imballato insieme*

LED Lichtring Ø26 cm Tischplatte mit Stativ Anello luminoso a LED Ø26 cm da tavolo con treppiede

u.m.vta: 1  10 

REF. 07293



- Led ring light durchmesser. 10 "
- Ring light net gewicht: 0,24 kg
- Ringfarbe: schwarz
- Leistung: 8 / 12w
- Spannung: ac85 / 240v
- Stromversorgung: usb-stromversorgung
- Led menge: 120 led beads
- Farbtemperatur: 3000k / 6500k
- Led-farbe: pure white / natural white / warm white / cold white
- Teile: 1 pc 10 "led ring light / 1 pc 14 cm desktop tripod stand / 1 pc schlauch
- Telefonhalter / 1 pc ballkopf / 1 pc telefonklammer / 1 pc fernblau
- Shutter / 1 pc einstellbarer telefonhalter / 1 pc 1,6 tripod / 1 tasche

- *Diametro luce anello led. 10 "*
- *Peso netto anello leggero: 0,24 kg*
- *Colore anello: nero*
- *Potenza: 8 / 12w*
- *Tensione: ac85 / 240v*
- *Alimentazione: usb alimentata*
- *Qtà led: 120 perline led*
- *Temperatura colore: 3000k / 6500k*
- *Colore led: bianco puro / bianco naturale / bianco caldo / bianco freddo*
- *Parti: 1 luce ad anello led da 10 " / 1 supporto treppiede da scrivania da 14 cm / 1 tubo flessibile*
- *Porta telefono / 1 testa a sfera per pc / 1 clip per telefono per pc / 1 bluetooth remoto per pc*
- *Otturatore / 1 porta telefono regolabile da 1 pc / 1 treppiede da 1,6 pc / 1 borsa da trasporto*

Kosmetikkoffer Valigetta portautensili

u.m.vta: 1	 1
------------	---

●
REF. 07320/50



●
REF. 07320/63

●
REF. 07321/50



●
REF. 07321/63



- Material: Kunstleder
- Ideal zum Aufbewahren von Schminkeprodukten und kleinen Utensilien.
- Verschluss: Reißverschluss

- Materiale: Similpelle
- Ideale per riporre prodotti per il trucco e piccoli utensili.
- Chiusura: cerniera lampo

Koffer Aluminium Valigie in alluminio

u.m.vta: 1		4
------------	---	---

Für Utensilien, innen 6
Fächer und 4 Ablagen
*Per strumenti, interno
composto da 6 scomparti
4 vassoi*



REF.03598



REF.03599

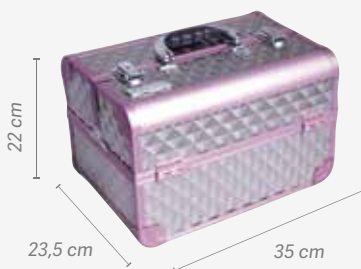

u.m.vta: 1		6
------------	---	---

REF.02318



u.m.vta: 1		4
------------	---	---

REF.02317



Alle Koffer werden leer verkauft
Tutte le valigie vengono vendute vuote

Koffer Aluminium Valigia in alluminio

u.m.vta: 1	 4
------------	---

Alle Koffer werden leer verkauft
Tutte le valigie vengono vendute vuote

REF.01492



Koffer PVC schwarz Valigia in PVC nera

u.m.vta: 1	 4
------------	---

Alle Koffer werden leer verkauft
Tutte le valigie vengono vendute vuote

REF.02925

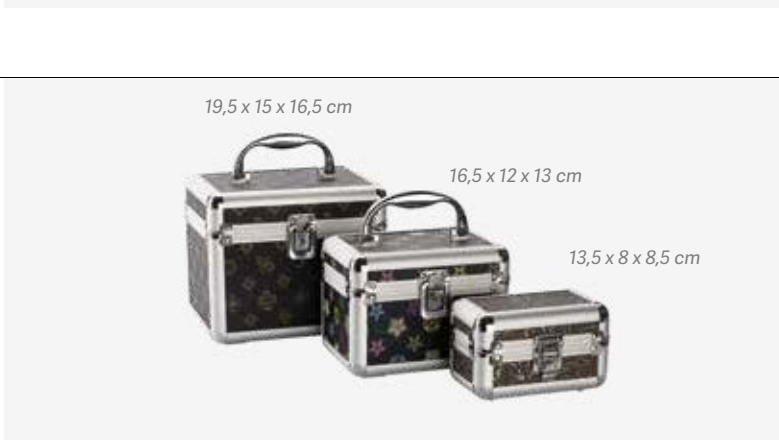

Set aus 3 verschiedenen Koffern PVC Set di 3 valigie assortite in PVC

u.m.vta: 1	 4
------------	---

Alle Koffer werden leer verkauft
Tutte le valigie vengono vendute vuote

REF.02594

Trolley-Koffer Valigia trolley

u.m.vta: 1	 1
------------	---

Mit Fächern und Spiegel
Con scomparti e specchio



REF.03814/50



Koffer für Make-up, Kosmetik und Schönheitsbehandlungen Valigetta per trucco, cosmetici ed estetica

u.m.vta: 1		4
------------	---	---

Mit 4 ausziehbaren Ablagen und mit 12 variablen Fächern. Bietet viel Platz im Inneren, auch für größere Produkte. Umfasst zwei Steckschlösser und zwei Ersatzschlüssel.

Con 4 vassoi estraibili e con 12 scomparti variabili. Dispone di un ampio spazio all'interno per i prodotti più grandi. Include due serrature e due chiavi di riserva.



REF.04940/50



REF.04940/54



REF.04940/70



u.m.vta: 1		4
------------	---	---

Mit ausziehbaren Ablagen (2 an jeder Seite). Jede davon mit 4 Ablagen. Großer Innenraum, aufgeteilt in 4 Bereiche. Enthält im Inneren einen Riemen, um den Koffer über die Schulter zu hängen, und zwei Steckschlösser mit zwei Ersatzschlüsseln.

Con ripiani estraibili (2 su ogni lato). Ogni ripiano ha 4 scomparti. Ampio spazio interno strutturabile in 4 sezioni. Include all'interno una fascia per appendere la valigia sulla spalla e due serrature con due chiavi di scorta.



REF.04941/50



REF.04941/54



REF.04941/70



Koffer für Make-up, Kosmetik und Schönheitsbehandlungen Valigetta per trucco, cosmetici ed estetica

u.m.vta: 1		4
------------	---	---

REF.04942/50





REF.04942/54

Mit ausziehbaren Ablagen (2 an jeder Seite). Jede davon mit 4 Ablagen. Großer Innenraum, aufgeteilt in 4 Bereiche. Enthält im Inneren einen Riemen, um den Koffer über die Schulter zu hängen, und zwei Steckschlösser mit zwei Ersatzschlüsseln.

Con ripiani estraibili (2 su ogni lato). Ogni ripiano ha 4 scomparti. Ampio spazio interno strutturabile in 4 sezioni. Include all'interno una fascia per appendere la valigia sulla spalla e due serrature con due chiavi di scorta.

Beutel für Utensilien schwarz Borsa portautensili nera

u.m.vta: 1		6	
------------	---	---	---

REF. 02516



Trolley-Koffer 4 Bereiche Valigia trolley a 4 blocchi

Alle Koffer werden leer verkauft
Tutte le valigie vengono vendute vuote

u.m.vta: 1		1
------------	---	---

Der Trolley-Koffer von Pollié wurde auf der Grundlage einer Struktur von 2 modifizierbare Bereichen geschaffen, um dem Profi die Lagerung von Friseurutensilien, Make-up oder Kosmetik zu ermöglichen.

Der obere Teil des Koffers besteht aus drei ausziehbaren Ablagen. Von denen Jede in drei Fächer aufgeteilt ist.

In einem davon wiederum finden Sie zwölf kreisförmige Ablagen zur Lagerung von Nagellack, um dessen Abblättern zu verhindern und einen sicheren Transport zu erleichtern. Zudem kann das Innere des oberen Körpers gemäß Ihren Erfordernissen geändert werden, durch Variation der Struktur der Fächer. Schließlich ermöglicht Ihnen seine Funktion 2 in 1, über einen Handkoffer zu verfügen, oder wenn Sie es vorziehen, ihn dank seiner Nylonriemen über die Schulter zu hängen.

Der untere Teil des Koffers hat eine ausziehbare Ablage mit der Möglichkeit, 4 Fächer unterzubringen, ebenfalls modifizierbar, dank der Separatoren. Der untere Körper hat ein hohes Fassungsvermögen und bietet Ihnen die Möglichkeit eines leichteren Transports, da er in einen kleineren Koffer mit Deckel und Spiegel verstaut umgewandelt werden kann. Die Rollen sind über einen Flansch austauschbar. Der Trolley verfügt über zwei Steckschlösser und zwei Austauschschlüssel.

Il trolley Pollié è concepito sulla base di una struttura a 2 blocchi modificabili ed è studiato per facilitare ai professionisti la disposizione dei propri utensili da parrucchiere, trucco o cosmetici.

La parte superiore del trolley è composta da tre vassoi rimovibili. Ognuno di essi è diviso in tre scomparti.

A sua volta, in ognuno di essi, troverai dodici scomparti circolari pensati per riporre gli smalti per unghie affinché rimangano fermi facilitando così il loro trasporto in totale sicurezza. Inoltre, l'interno del blocco superiore può essere modificato in base alle proprie esigenze, variando la struttura degli scomparti. Infine, la sua funzione 2 in 1 ti permetterà di avere un bagaglio a mano o se preferisci puoi portarlo a tracolla grazie al suo cinturino in nylon.

La parte inferiore della valigia ha un ripiano estraibile con 4 scomparti a scelta, modificabili anche grazie ai divisori. La parte inferiore, con una grande capienza interna, ti darà la possibilità di effettuare un trasporto più leggero poiché può essere convertita in una valigia più piccola, con coperchio e specchio incorporato. Le ruote sono intercambiabili tramite la linguetta di aggancio. Il trolley ha due serrature e due chiavi di scorta.



REF.04939/50



REF.04939



Behälter für Organisation Scatola organizer

Leer
Vuoto

u.m.vta: 1  24



REF.04722

u.m.vta: 1  12





REF.04309

Mit Magnet
Magnetizzato



Transparentes Farbspray Spray colorato trasparente

u.m.vta: 12  84 

300 ml



REF.01372

330 ml



REF.00959

Rund
Rotondo

300 ml



REF.01484

300 ml



REF.01663



Kartenetui Aluminium Portacarte in alluminio

u.m.vta: 1	 400
------------	---

REF.02470



Flasche Dosierpumpe Bottiglia con pompetta dosatrice

u.m.vta: 20	 80
-------------	--

240 ml

REF.02880



Augenschutz UV Linse mit Etui Protezione per gli occhi con lente UV con custodia

u.m.vta: 10	 100
-------------	---

Umfasst eine zentrale Linse, die der Sicht dient
Include una lente centrale che consente la visione

REF.03195

Ohne Sicht
Senza visione

REF.03194



- Modell, das ein neuartiges spezielles System der Halterung umfasst, basierend auf einer transparenten Haarnadel aus Kunststofffaser
- Mit Etui zur Aufbewahrung des Augenschutzes

- Modello che comprende un innovativo sistema di bloccaggio speciale basato su una forcilla in fibra di plastica trasparente
- Con astuccio per riporre la protezione

Artikel, die ausschließlich in Spanien verkauft werden
Articoli in vendita esclusiva IN SPAGNA



Antiseptikum Daromix GH Antisettico Daromix GH

u.m.vta: 1  12

1 L

REF.06200

Desinfektionsmittel Limoseptol Disinfettante Limoseptol

u.m.vta: 1  20 

50 ml

REF. 06151

u.m.vta: 1  20

1 L

REF.06150



- AEMPS-Registrierungsnummer: 905-DE5
- Wasser-alkoholisches Antiseptikum zur hygienischen Händedesinfektion durch Reibung
- Wissenschaftlich garantierte Wirksamkeit
- Breites Biozid Spektrum ab 30 sec
- Hypoallergene Formel
- Bewahrt die Hautfeuchtigkeit
- Keine Hautreizung
- Schnell trocknend
- Wirksam als: Bakterizid, Levurozid, Viruzid und Mikrobakterizid



- Numero di registrazione AEMPS: 905-DE5
- Antisettico idroalcolico per la disinfezione igienica delle mani per sfregamento
- Efficacia scientificamente garantita
- Biocida ad ampio spettro a partire da 30 sec
- Formula ipoallergenica
- Preserva l'idratazione della pelle
- Non irritante per la pelle
- Asciuga velocemente
- Efficace come: battericida, lieviticida, viricida e microbattericida



- AEMPS-Registrierungsnummer: 47-DE5
- Hochwertiges Produkt, das ausschließlich für Hygiene, Reinigung und Desinfektion entwickelt wurde, für professionelle Utensilien eines Salons.
- Waschmittelwirkung - breites Spektrum
- Biologisch abbaubar - phosphatfrei und FORMOLFREI
- Keimtötende und desinfizierende Wirkung gegen: Bakterien, Hefen und Pilze
- Mischverhältnis
- 100 ml Produkt = 10 Liter Wasser

- Numero di registrazione AEMPS: 47-DE5
- Prodotto di alto livello sviluppato esclusivamente per l'igiene, la pulizia e la disinfezione degli utensili professionali nei centri estetici
- Azione detergente - Ampio spettro
- Biodegradabile - Senza fosfati e senza FORMOLO
- Efficacia germicida e DISINFETTANTE contro: batteri, lieviti e funghi
- Dose da mescolare
- 100 ml di prodotto = 10 litri di acqua

Flasche speziell für hydroalkoholisches gel und hydroalkoholische lösung Bottiglia speciale per gel e soluzione idroalcolica

u.m.vta: 1  3 



Mit wandhalterung
Con supporto a parete

300 ml

REF.07280



Desinfektionsmittel für oberflächen in sprayform Igienizzante per superfici in spray

u.m.vta: 1  12 

500 ml

REF.07232

Ideal für die Desinfektion und Reinigung jeder Art von Oberfläche: Metall, Kunststoff, Glas und Keramik.

- Möbel, Türen, Geländer, Spielzeug, WCs, Computertastaturen,
- Mäuse, Bildschirme, Arbeitsplätze

MERKMALE UND VORTEILE

- Harmlos beim Kontakt mit der Haut.
- Schnelle und effektive Reinigungs- und igienizacióswirkung.
- Verdampft vollständig, ohne Reste zu hinterlassen.
- Greift Kunststoff oder Gummi nicht an.

Ideale per igienizzare e pulire qualsiasi tipo di superficie: metallo, plastica, vetro e ceramica.

- *Mobili, porte, ringhiere, giocattoli, servizi igienici, tastiere di computer, mouse, schermi... luoghi di lavoro*

CARATTERISTICHE E VANTAGGI

- *Innocuo a contatto con la pelle.*
- *Rapida ed efficace azione detergente e igienizzante.*
- *Evapora completamente senza lasciare residui.*
- *Non attacca le plastiche o le gomme.*



Seifenschale Kunststoff Portasapone in plastica

u.m.vta: 1		40
------------	---	----

REF.02197



Saugglocke mit Balg WC Stantuffo per WC a soffietto

u.m.vta: 10		10
-------------	---	----

REF.00931



Griff für Besen Manico di scopa

u.m.vta: 12		12
-------------	---	----

REF.01131

- Leicht zu reinigen und lange haltbar
- Ständer aus Kunststoff
- Ideal für jede Art von Boden, insbesondere Parkett

- Facile da pulire e di lunga durata
- Gancio in plastica
- Ideale per tutti i tipi di pavimento, in particolare il parquet



u.m.vta: 10		10
-------------	---	----

REF.01365

Ausziehbar 140 cm
Allungabile 140 cm



Gummibesen Scope di gomma

u.m.vta: 4		16
------------	---	----

Mit Lasche
Con aletta

REF.01223



u.m.vta: 5		20	
------------	---	----	---

REF. 01285/50



u.m.vta: 5		20
------------	---	----

REF.02420



- Leicht zu reinigen und mit langer Lebensdauer, beseitigt den Staub dank der wirksamen Anordnung seiner Borsten, ohne ihn aufzuwirbeln, wodurch er ideal ist für Allergiker, da er ein sauberes Ambiente fördert.

- Facile da pulire e di lunga durata. L'efficienza del design dei suoi denti riesce a trascinare la polvere senza sollevarla, rendendola ideale per chi soffre di allergie in quanto aiuta a mantenere i locali puliti

TASSEL

08

Mobiliar Mobilia

*Kosmetikstühle, Hocker, Stühle, Ständer,
Wagen, Handkoffer, Make-up-Stühle...*

*Lettini, sgabelli, sedie, supporti, carrelli,
valigette, poltrone per il trucco...*



Kosmetikstuhl für Massage tragbar Lettino da massaggio portatile

u.m.vta: 1	 1
------------	---

Gewicht: 17,5 kg

Peso: 17,5 kg

REF.07384



Kosmetikstuhl für Massage tragbar Lettino da massaggio portatile

u.m.vta: 1	 1
------------	---

- Aluminium
- Gewicht: 16 kg



- Alluminio
- Peso: 16 kg

REF.07385



Kosmetikstuhl Massage Metallstruktur

Letto da massaggio con struttura in metallo

u.m.vta: 1  1 

REF.02738



- Schaumstoffdichte: 30kg/m³
- Gewicht: 17 kg

- Densità della spugna: 30kg/m³
- Peso: 17 kg



Kosmetikstuhl spezial Massage

Letto da massaggio speciale

u.m.vta: 1  1 

REF. 02739

REF. 02739/50

- Schaumstoffdichte: 30kg/m³
- Gewicht: 31 kg
- Densità della spugna: 30kg/m³
- Peso: 31 kg



Ständer für Papierrollen Kosmetikstuhl

Portarotoli per carta copriettino

u.m.vta: 1  5

Ständer für die Wand
Supporto a parete

REF.01168



Hydraulischer Kosmetikstuhl 3 Komponenten Lettino idraulica 3 blocchi

u.m.vta: 1  1 

REF. 03031

- Schaumstoffdichte: 162 kg/m³
- Mit Gesichtslöch unter dem Polster der Kopfstütze
- Dicke PVC 1,1 / 1,2 cm
- Weißer Schaumstoff 1. Qualität
- Bequem, solide und vielseitig
- Gewicht: 62 kg

- Densità della spugna: 162 kg/m³
- Con foro per il viso sotto il cuscino del poggiatesta
- Spessore PVC 1,1 / 1,2 cm
- Gommapiuma bianca di prima qualità
- Comodo, solido e versatile
- Peso: 62 kg



Elektrischer Kosmetikstuhl 3 Komponenten Lettino elettrico 3 blocchi

u.m.vta: 1  1

REF. 03030

- Schaumstoffdichte: 162 kg/m³
- Ausziehbare Arme
- Mit Gesichtslöch unter dem Polster der Kopfstütze
- Weißer Schaumstoff 1. Qualität
- Sitz 9,5 cm
- Bequem, solide und vielseitig
- 3 Komponenten - 3 Motoren
- Traglast: 200 kg
- Gewicht: 70 kg

- Densità della spugna: 162 kg/m³
- Braccioli smontabili
- Con foro per il viso sotto il cuscino del poggiatesta
- Gommapiuma bianca di prima qualità
- Seduta 9,5 cm
- Comodo, solido e versatile
- 3 blocchi - 3 motori
- Supporta 200 Kg
- Peso: 70 kg



Spa-Kosmetikstuhl Lettino Spa

u.m.vta: 1	 1
------------	---

REF.03032

- Kopfstütze NICHT abnehmbar
- Gewicht: 53 kg
- Poggiatesta NON rimovibile
- Peso: 53 kg



Kleine Leiter Holz Spa Scaletta Spa in legno

u.m.vta: 1	 1
------------	---

REF.03072



Wandschirm Holz Spa
Separé spa in legno

u.m.vta: 1  1

REF.03078



Regal Holz Spa
Scaffale spa in legno

u.m.vta: 1  1

REF.03071



Maniküretisch Tavolo da manicure

u.m.vta: 1	 1
------------	---

REF.02139

- Maniküretisch, bestehend aus weißer Holzplatte, Fuß aus Aluminium und thermogeformter Stütze mit Rollen
- Umfasst Lampe, Handballenauflage aus Schaumstoff und einen praktischen Organizer für Utensilien
- Ohne Sauger
- Gewicht: 22 kg

- *Manicure table made up of a Bianco wooden board, an aluminium base and a thermoformed piece of furniture with wheels*
- *Includes a lamp, a foam palm rest and a handy organiser for tools*
- *Weight: 22 kg*
- *Vacuum cleaner not included*



Maniküretisch mit Sauger Tavolo da manicure con aspirazione

u.m.vta: 1	 1
------------	---

REF.03067

- Maniküretisch, bestehend aus weißer Holzplatte, Fuß aus Aluminium und thermogeformter Stütze mit Rollen
- Umfasst Lampe, Handballenauflage aus Schaumstoff und einen praktischen Organizer für Utensilien
- Mit Sauger 20 W
- Gewicht: 22kg

- *Tavolo per manicure composto da tavolo in legno bianco, gamba in alluminio e mobiletto*
- *termoformato con ruote*
- *Include lampada, poggiamani in gommapiuma e un pratico organizer per gli utensili*
- *Con aspiratore da 20W*
- *Peso: 22kg*



Klappbarer Maniküretisch mit Sauger und Rollen Tavolo da manicure pieghevole con ventosa e ruote

u.m.vta: 1		1
------------	---	---

REF.04278

- Mit Sauger von 3000 rpm
30 W
- Gewicht: 12 kg
- Con aspiratore da 3000 rpm
30 W.
- Peso: 12 kg

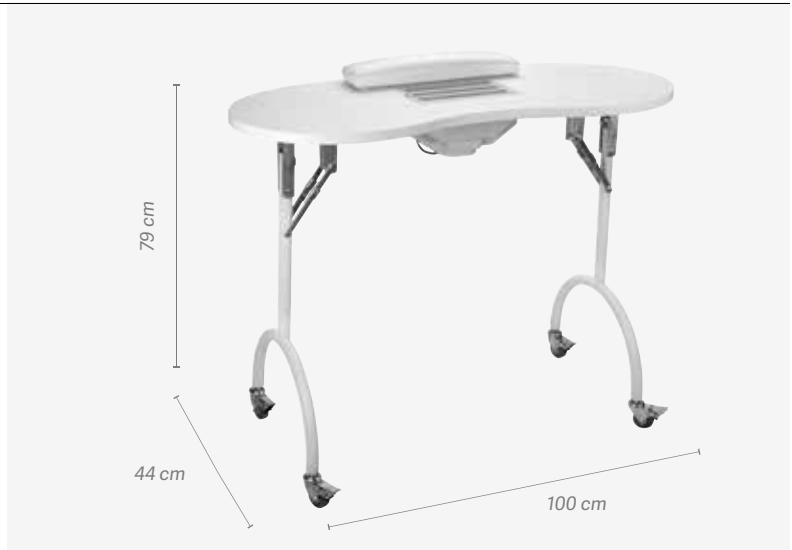

Maniküretisch aus weißem Holz Tavolo da manicure in legno bianco



u.m.vta: 1		1
------------	---	---

- Gewicht: 33 kg
- Peso: 33 kg

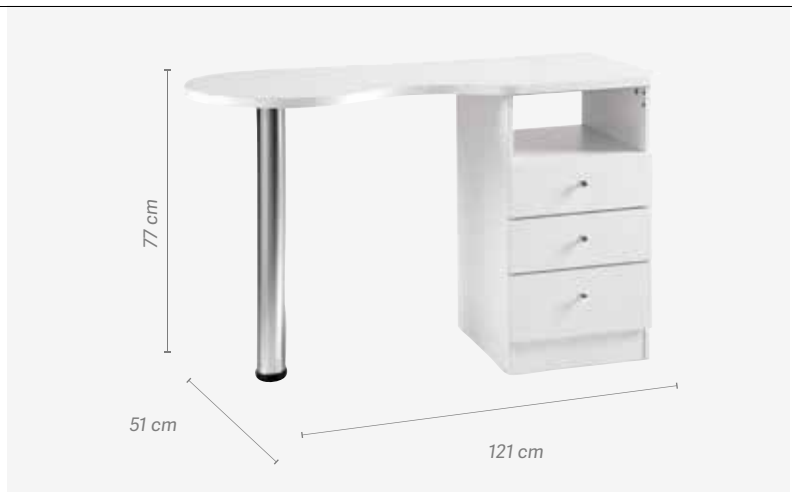
REF.03934



Wagen Schönheitsbehandlung Pollié Carrello Pollié

u.m.vta: 1		1	
------------	---	---	---

- Gewicht: 12 kg
- Peso: 12 kg

REF. 02839



SCAN
ME!



Tischlampe für Maniküre

Lampada da tavolo per manicure

u.m.vta: 1	 1
------------	---

REF.03187

- Lampe in Aluminiumfarbe
- Neonlicht
- Maß: 72 cm
- Wird mit Leuchtröhre von 20 W und zusätzlicher Ersatzröhre geliefert

- Lampada in alluminio
- Luce al neon
- Misure: 72 cm
- Fornito di lampada fluorescente da 20W e ricambio



Wagen für Maniküre/Pediküre

Carrello per manicure/pedicure

u.m.vta: 1	 1
------------	---



REF.03944/50



REF.03944/58



Rezeptionsschalter aus Holz und Metall Spiegel-Effekt Bancone reception in legno e metallo a effetto specchio

u.m.vta: 1  1

REF.03935

Mit Innenfächern aus Holz zur Lagerung und als Ablage

Con scomparti interni in legno per riporre e ripiano



Wartesofa 3 Plätze Divano attesa 3 posti

u.m.vta: 1  1

Aus Kunstleder
In similpelle

REF.03950



Empfang EARTH Reception EARTH

u.m.vta: 1  1

Graphit · Grafite



REF.04518/50

Eiche · Rovere



REF.04518/65

Weiß · Bianca



REF.04518/58

- Laminat
- Mit verstellbaren Einlegeböden und 1 Schublade

- Laminato
- Con ripiani regolabili e 1 cassetto



Hocker STREET Sgabello STREET

u.m.vta: 1  1●
REF.06103/50SCAN
ME!○
REF.06103/58

Hocker STREET klassisch mit Hydraulikpumpe zur Einstellung auf die gewünschte Höhe bei jeder Arbeit

Sgabello STREET classico con pompa idraulica per regolare l'altezza a quella desiderata per ogni lavoro.

Vergleichsartikel 04419 - 06103
Comparativa 04419 - 06103



Hocker Metallbasis Sgabello con base in metallo

u.m.vta: 1  1●
REF.04419/50SCAN
ME!○
REF.04419/58

Hocker RODEO Sgabello RODEO

u.m.vta: 1  1

REF.01964



Hocker URBAN Sgabello URBAN

u.m.vta: 1	 1
------------	---

●
REF.06102/50

Hocker URBAN ergonomisch mit Hydraulikpumpe zur Einstellung der Höhe auf die gewünschte bei jeder Arbeit. Seine Form passt sich an den Körper an und fördert damit eine bessere Haltung und verhindert Rückenschmerzen nach vielen Stunden Arbeit

○
REF.06102/58

Sgabello URBAN ergonomico con pompa idraulica, per regolare l'altezza a quella desiderata per ogni lavoro. La sua forma si adatta al corpo e di conseguenza favorisce una migliore postura e previene il mal di schiena dopo molte ore di lavoro.



SCAN ME!



Vergleichsartikel 04382 - 06102
Comparativa 04382 - 06102



Hocker RODEO Metallbasis Sgabello RODEO con base in metallo

u.m.vta: 1	 1
------------	---

●
REF.04382/50

○
REF.04382/58



SCAN ME!



Lehnstuhl Poltrona reclinabile

u.m.vta: 1	 1	
------------	---	---

○
REF. 02975/58

- Verstellbar 130° / idraulisch
 - Breite von Arm zu Arm: 57 cm
 - Breite Oberteil des Stuhls: 19 cm
 - Lehne: 51 x 41 cm
 - Höhe Oberteil: 13 cm
 - Abstand zwischen Lehne und Oberteil: 14 cm
 - Gewicht: 32,5 kg
 - Ausziehbares Oberteil mit einer Position
- Reclinabile 130° / idraulica
 - Larghezza da bracciolo a bracciolo: 57 cm
 - Larghezza del poggiatesta della sedia: 19 cm
 - Schienale: 51 x 41 cm
 - Altezza del poggiatesta: 13 cm
 - Distanza tra schienale e poggiatesta: 14 cm
 - Peso: 32,5 kg
 - Poggiatesta smontabile con una posizione



Lehnstuhl, verstellbar

Poltrone regolabile con schienale

u.m.vta: 1  1

REF.02730/58



Verstellbarer Stuhl

Poltrona regolabile

u.m.vta: 1  1

REF.02732



REF.02732/58



Lehnstuhl, verstellbar

Poltrone regolabile con schienale

u.m.vta: 1  1

REF.03937/50



REF.03937/58



Lehnstuhl FASHION

Poltrone con schienale FASHION

u.m.vta: 1  1

REF.06101/58

Stuhl FASHION mit Lehne für mehr Komfort und Abstützung für den Rücken. Die Rollen sind so konzipiert, dass sich das Haar nicht in ihnen verfängt. Leicht zu reinigen

Poltrona FASHION con schienale per un maggiore comfort e sostegno per la schiena. Le ruote sono progettate per evitare che i capelli vi rimangano impigliati. Facili da pulire.



SCAN
ME!



Tattoo-Ständer

Poggiabracchio per tatuaggi

u.m.vta: 1  1

REF.04915



- Verstellbar und kippbar
- Polsterung: 37 x 21 cm
- *Regolabile e inclinabile*
- *Imbottitura: 37 x 21 cm*

Nackenstütze

Supporto per la nuca

u.m.vta: 1  1

REF.03842



- Polsterung: 23 x 6 cm
- *Imbottitura: 23 x 6 cm*

Ständer Pediküre

Treppiede per pedicure

u.m.vta: 1  1

REF.03627



- Ständer Pediküre 20 x 17 cm kippbar
- 1,94 kg
- *Supporto per pedicure 20 x 17 cm inclinabile*
- 1,94 kg

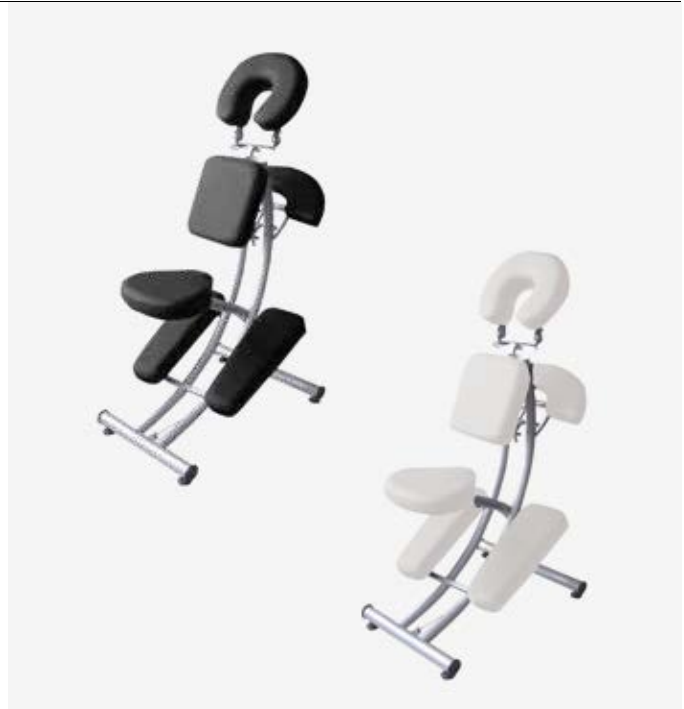

Massagstuhl Poltrona da massaggio

u.m.vta: 1  1●
REF.02740/50○
REF.02740

Spezialstuhl Pediküre mit Fußwanne Sedia speciale per pedicure con lavapiedi

u.m.vta: 1  1 

REF. 02741

Spa Pediküre Stuhl Sedia per pedicure spa

u.m.vta: 1  1

REF. 07341

- Mit verstellbarer Rückenlehne
- Con schienale regolabile



Handkoffer mit Schminktisch Valigetta per il trucco

u.m.vta: 1  1

Schminktisch mit 6 klappbaren Leuchten und Rollen. Konvertierbar in einen bequemen Trolley-Koffer + 2 Bechern für Pinsel. Europäische Anschlüsse.

Mobile da trucco con 6 luci e ruote pieghevoli. Trasformabile in un comodo trolley + 2 portaspazzole. Presa europea.

17 kg

REF.04937/50



Handkoffer mit Schminktisch Valigetta per il trucco

u.m.vta: 1  1

17 kg

REF.04937/54



Kopfstütze schwarz Poggiatesta nero

u.m.vta: 1  6

REF.06157

- Nur geeignet für Ref.-Nr. 06156/50 und 06156/54
- Adatto solo per rif. 06156/50 e 06156/54



Make-up-Stuhl klappbar Sedia da trucco pieghevole

u.m.vta: 1  1

REF.06156/50



REF.06156/54

- deal für Make-up
- Ideale per il trucco

Mit Tranporthülle
Include custodia per
il trasporto



Aufhänger für Saugnapf

Gancio a ventosa

u.m.vta: 15  15

REF.02904

- Tasche mit zwei Saugnapf-Aufhängern
- *Borsa con due ganci a ventosa*



Handtuch-Organizer

Organizzatore di asciugamani

u.m.vta: 1  6

REF.04378

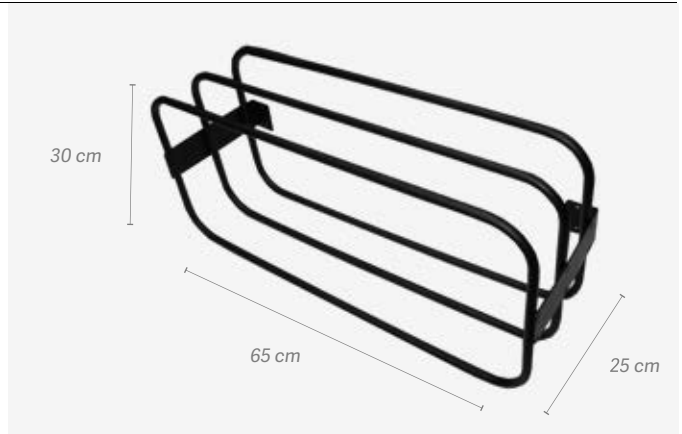

Handtuchbehälter

Porta asciugamani

u.m.vta: 1  4

REF.03159

- Mit Rollen
- Waschbare Taschen
- Struktur aus Edelstahl
- *Con ruote*
- *Borsa contenitore lavabile*
- *Struttura in acciaio inox*



ABDECKUNGEN UND PAPIERBAHREN	777	ERSATZTEILE MANIKÜRE-DREHMASCHINEN	683
ABDECKUNGEN UND TÜCHER	778-779	ERWEITERUNGSSATZ	385
ABDECKUNGEN ZUM NAGELNSCHNEIDEN UND ZIEGELN	719	EUROSTIL VERDAMPFER	33
ABGEWINKELTER ROUGEPINSEL	747	EUROSTIL SCHNEIDEMASCHINEN	424
ACETAT SHELL WHISK COMB	324	EUROSTIL SCHNEIDEMASCHINEN	424-425
ACETATKÄMME	325-326	EUROSTIL AUSRÜSTUNGSMASCHINEN	425
ACRYLCEL	656-657	EUROSTIL TASCHENMESSER	455
ADSTRING GAZE SKINS LINIE	590	EUROSTIL KÄMME	492
AFTER SHAVE SPLASH	508	EUROSTIL BÜRSTEN	482-483
AFTER SHAVES MYRSOL	513	EUROSTIL PROFESSIONELLE KÄMME	287-296,298
AKTENTASCHEN UND SCHMINKSTÜHLE	837-838	EUROSTIL SCHERE	470-471
AKTIVATOREN	28-29	EYELINER	741
ALUMINIUM KARTENHALTER	400	FACEPRO GESICHTSSCHILD	399
ALUMINIUMFOLIE	77-79	FÄLLE	56-557,810-815
ALUMINIUM WÄRMEBÜRSTEN	285	FALLPRÄVENTIONSBLISTERN	517
ANDREA AUGENBRAUEN	775	FARBmuster ERWEITERUNGEN	385
ANDREA WIMPERN	767-768	FEDERTASCHENMESSER UND KLINGEN	456
ANONYME KÄMME	301	FEILEN UND POLIERBLÖCKE	692-708
ANPASSBARES BRAUSESET	243.535	FEUCHTIGKEITSSPENDENDE LOTION KÖRPERMILCH	606
ANTI-BESCHLAG-SCHUTZBRILLE	791	FIXIERER	617-620
ANTI-CELLULITE UND STRAFFUNG	605	FLACHBÜRSTEN ENTWIRREN	277
ANTI-LÄUSE-ELEKTRISCHER KAMM	52	FLAUSCHKAMM AUS HOLZ	324
ANTISTATISCHER KIMONO	117	FLEXIBLES PVC-DUSCHROHR	245.537
ARGANLINIE	146	FRISEURBÜRSTE	479
AROMA SENSATION LINIE	149-152	FRISEURBÜRSTEN	475
ÄTHERISCHE ÖLE	592-595	FRISEURKÄMMLINIE	491
AUGENBRAUENSTIFT AUS HOLZ POLLIE	740	FRISEURLINIENBÜRSTEN	480-481
AUGENSCHUTZ	541	FRISEURPOLY	521
AUSSTELLER	740	FRISEURSCHÜRZE	546
AUSSTELLER TOUCH-UP ROOTS RAGNAR	497	FRISEURSESSL	233
		FRISEURSTUHL	522-526
		FRISEURSTÜHLE	230-232,234-237
		FRISUREN UND UMHÄNGE	542
BALG-HOLZGRIFFBÜRSTEN	253-254,256	GABELN	175-180
BALGBÜRSTE MIT HOLZGRIFF	252	GEFÜLLTER BOGEN	353-357
BALGBÜRSTE MIT KUNSTSTOFFGRIFF	258-263	GEHÖRSCHUTZ	541
BALGBÜRSTEN MIT GUMMIGRIFF	264-265	GEL DIE LEGENDEN	516
BAMBUSBÜRSTEN	255	GEL- UND ACRYLPINSEL	61-662
BARBER LINE RASIERER	433	GELSPENDER	368
BARBER LINE SCHWARZER WACHSFIXIERER	441	GESICHTSMASKE	591
BARBER LINE RASIERSET	478	GESICHTSMASKEN	800
BARBER LINE SCHERE	463.469	GESICHTSPEELING	580
BARBER LINE TASCHENMESSER	449-452	GESICHTSSCHILD	400
BARBERSHOP-MATTE RAGNAR	437	GRADUIERTE APPLIKATORFLASCHEN	76
BARTBALSAM	509	GRAVITY VOLUMINISIERENDES PULVER	504
BARTÖL	509	GRIFF FÜR BESEN	410
BAUMWOLLE	387,791-792	GROSSE SCHMELZGERÄTE	621
BEHÄLTER FÜR SCHERE	377	GRUNDÖLE	601-603
BESEN	569	GUMMI UND KRAWATTEN	192-198
BESONDERHEITEN PEDIKÜRE	725-735	GUMMIBESEN	410
BEUTEL MIT CLIPS-VERLÄNGERUNGEN	384	HAARFÄRBE	136-138
BLEISTIFTSPIZZER	759	HAARFASERN	164.518
BOLEN	64-67	HAARFASERN ANZEIGEN	519
BOURBON-SHAMPOO 1874	504	HAARPACKUNG CAPTAIN COOK	504
BÜRSTEN	476	HAARSCHNEIDER	377
BÜRSTEN	759	HAARSCHNEIDER UND RASIERER	378-379
BÜRSTEN	784	HAARSTAUBSAUGER	57.442
BÜRSTEN FÜR EISEN	278	HAARVERLUST VORBEUGENDES SHAMPOO	517
BÜRSTEN MIT HOLZSTIE	755-757	HAARVORHÄNGE	381
		HÄKELTASCHE	350
		HALSPAPIER	539-540
CAPS	344.346-349.351	HALSPAPIERHALTER	541
CAPTAIN BARBERSHOP MAT	437	HALTER	562
CAPTAIN COOK RASIERER	434	HÄRMOSTATISCHE STREICHHÖLZER	516
CAPTAIN COOK ÖLE	505	HANDCREME	660
CAPTAIN COOK BÄRTPACKUNG	504	HANDSCHUHE	81-83
CAPTAIN COOK COMBS	489-490	HANDSCHUHE UND ZUBEHÖR	560-561
CAPTAIN COOK CREME	499	HANDTUCH-ORGANISATOR	839
CAPTAIN COOK CREAMES	505	HANDTUCHAUFHÄNGE-ORGANIZER	535
CAPTAIN COOK CUTTING CAPE	547	HANDTUCHAUFHÄNGER ORGANIZER	243
CAPTAIN COOK SALBEN	500-502	HANDTUCHBEHÄLTER	535-839
CAPTAIN COOK SCHERE	466-468	HANDTÜCHER	404.558-559.784
CAPTAIN COOK SHAMPOO	499	HAUT- UND NAGELSCHERE	722-723
CAPTAIN COOK TASCHENMESSER	453-454	HAUTSCHNEIDEZANGE	711
CAPTAIN COOK TOUCH-UP MASCHINEN	427-428,431	HAUTSCHNEIDEZANGE	712-715,717
CARBON COMBS	299-300,493	HELLFARBIGER FARBSTOFF	121-132
CERIOTTI VERDAMPFER	32	HELMTROCKNER	30-31
CHROM-BRAUSEKOPF	244.536	HELMTROCKNER ORLA	33
CLIPS	169-173.383	HELMTROCKNER VALERA	34
CLIPS MIT PERLEN	200-201	HOCKER	221-222
CLIPS UND GABELN	174	HOCKER, STÜHLE UND STÜTZEN	832-836
CLIPS UND KLEMMEN	198	HOLZBLEISTIFT LIPPEN POLLIE	739
COCKTAIL-SHAKER UND METER	75	HOLZBÜRSTE MIT GUMMIGRIFF	252
CREMES UND BEHANDLUNGEN	583-585,587,589	HOLZDISPLAY 20 BÜRSTEN	254
		HOLZFARBKÄMME	320-321
DAMPFER UND ZUBEHÖR	597-598	HOLZKREISBÜRSTE	249-251
DAS RASIEREN CO	507-508.510	HOLZLEITER SPA	826
DESINFIZIATIONSMITTEL, STERILISATOREN	563-565	HOLZWICKELWELLEN	331
DESINFIZIATIONSTEPPICH SCHUHE	791	HYALURON-KOSMETIKLINIE	581-582
DIE LEGENDEN	516	HYALURON-SHAMPOO	144
DIFFUSOREN	26-27	HYALURONMASKE	144
DISC-TASCHE FÜR ERWEITERUNGEN	385	HYGIENE UND DESINFIZIATIONSMITTEL	818-821
DISPLAY QUASTE AKTIVE ZELLEN	586	IONISCHE WÄRMEBÜRSTEN	282
DISPLAYBÜRSTEN	758	IONISCHER DUSCHKOPF	243.535
DISPLAYSCHERE	377	KABUKI-PINSEL	752-753
DOSEN FARBKÄMME	315-319	KALTE VERBANDBEHANDLUNGSFLÜSSIGKEIT	608
DREHMASCHINEN	681-682,686-687	KÄMM FÄLLE	302-303
DREIECKIGES TROCKNERNETZ	345	KÄMM MIT STUFEN	280.495
DUSCHE MIT UNTERSTÜTZUNG	243.535	KÄMME VERSCHIEDENE FARBEN	311-314
DUSCHE MIT UNTERSTÜTZUNG LAVACAZEZAS	244.536	KÄMMMASCHINEN	84-85
DUSCHROHR AUS FLEXIBLEM NYLON	245.537	KÄMMSPENDER FÜR EINEN GEBRAUCH	297
DÜSEN EUROSTIL	435	KAPILLARES OXIDIERMITTEL	132-135
		KAPILLARFASERZERSTÄUBER	518
EDELSTAHL KLEMME. ALL GEMEINE VERWENDUNG	784	KAPITÄN KOCH	498-504
EINHEBEL FÜR LAVACESAS	243.535	KERAMIKBÜRSTEN	282
EINHEBEL- UND BRAUSESET	536	KINDERSTÜHLE	529
EINHEBEL-WASCHANLAGE	244	KINDERUMHÄNGE	104-105
EINLEITUNG SCHERE	372.472	KLAMMERN 1	189-191
EINLEITUNG SCHERE	373	KLEBSTOFF ZUR BEFESTIGUNG DES HAARVORHANGS	384
EINMALGEBRAUCH	785-791	KLEIDUNG/UNIFORMEN LACLA	802-807
EINWEG-UMHÄNGE	86-89	KLEINE EISEN-FRISEURLINIE	441
EINWEGMESSER	460	KLINGEN	457-459
ELEKTRISCHE NADEL	636	KOFFER UND TASCHE	388-396
ELEKTRISCHE WÄRMEBÜRST	52	KONJAK-SCHWÄMME	599
ELEKTROLEITENDES GEL	637	KOPFWÄSCHER	224-229,527-528
EMAILLE P-LACK	653-655		
EMPFÄNGSKALEN UND ANDERE	533-534		
ENTWIRRUNGSBÜRSTE	267		
ENTWURFBALGBÜRSTE	257		
ERGÄNZENDE MÖBEL	827		
ERSATZGUMMI LOCKEN WIMPERN	774		
ERSATZTEILE DREHMASCHINEN	684		
ERSATZTEILE FÜR DREHMASCHINEN	688-689		

KOPFWASCHER WASCHBECKENVENTIL	244-536	SCHAUFENSTERPUPPE KÖPFT EUROSTIL	571-572
KÖRPER-/GESICHTS-PEELING-KIT	604	SCHIEBENABFLUSSROHR	245-537
KÖRPERPEELING	604	SCHIERE RAGNAR	464-465
KOSMETIK NACH DEPILATION	634-635	SCHIRENETUIS	374-376
KOSMETIK-ACCESSOIRES	609	SCHICHTEN	90-101,543-545
KOSMETIK-ACCESSOIRES	680	SCHMINKSCHWAMM	744-746
KREISBÜRSTE	286	SCHNEIDEMASCHINEN CAPTAIN	416-421
KREPPBÜRSTEN	247	SCHNEIDMASCHINEN RAGNAR	422-423
KUGELBÜRSTE 3D	269	SCHNURRARBARTBALSAM	509
KÜNSTLICHE NAGELKNIPPER	718	SCHÜRZE CAPTAIN COOK	547
KUNSTSTOFF-KREISBÜRSTE	249	SCHÜRZE FÜR BÜRSTEN UND BÜRSTEN	747
KUNSTSTOFFBLEISTIFTE POLLIÉ	737	SCHÜRZEN	103
KUNSTSTOFFWICKEL	332-334	SCHWAMM ZUM ABSCHINKEN	742-743
LACKE CAPTAIN COOK	503	SCHWARZE MASKE TIEFENREINIGUNG	580
LACKHAARFASERN	519	SCHWARZER WERKZEUGHALTER	397
LACLA GESICHTSMASKEN	801	SCHWARZES DUSCHBECKEN	244-536
LACLA STOLEN	111-117	SCHWEISSPINZETTENVERLÄNGERUNGEN	53
LACLA-CASACAS	107-110	SEPARATOREN FÜR HAARE	541
LACLA-HOSE	118-119	SHAMPOO	141,146-147,153-154
LAMPEN	73-678	SHAMPOO CAPTAIN COOK	498
LED-RINGLICHT	808-809	SHAMPOO UND MASKEN	142-143,145,155-157
LENDRE KÄMME/BABYBÜRSTEN	279	SILIKON PINSELREINIGER	760
LIDSCHATTEN-APPLIKATORTASCHE	759	SILKOMB PROFESSIONELLE KÄMME	310
LINKSHÄNDERSCHERE	366	SILKOMB-KÄMME	494
LOCKEN WIMPERN	774	SKLETTBÜRSTEN	272-276
LOCKENWICKLER-SET	339	SPENDER	409
LOCKENZANGE	46-51	SPENDER	80
LÖSUNGSMITTEL	384	SPEZIALSTUHL FÜR KINDER	530
LUFTBÜRSTEN	286	SPEZIELLE AKADEMIE-SCHERE	373
LUPEN	690-691	SPEZIELLE KISSEN FÜR KINDER	220-530
MAGNETISCHE HANDGELENKSTÜTZE	181	SPEZIELLE LINKSHÄNDERSCHEREN	473
MAKE-UP-PINSEL-ETUI	760-761	SPEZIELLER BARTKAMM	478
MANIKÜRE-/PEDIKÜRE-WAGEN	830	SPEZIELLER KAMM DOCHTE	350
MANIKÜRE-TISCHLEUCHTE	830	SPIEGEL	400.531.566.793-799
MANIKÜRE-ZUBEHÖR	721	SPIESSKASTEN	343
MANIKÜRETISCHE	828-829	SPIESSTASCHE	343
MANNQUIN NATURHAAR	R 210-211	SPIRALBÜRSTEN	248
MANSCHETTENKÄMME	322-323	SPRINKLER	68-73
MASCARA	741	SPRÜHGERÄTE	401-403,552-555,816
MASSAGE-SHAMPOOBÜRSTE	319	SPUNLACE-HANDTÜCHER	204,780-781
MATADOR PROFESSIONELLE KÄMME	307-309	STERILISATOREN	54-56,443-445,709-710
METAL PICK KAMMHAKEN MECHAS	350	STIFTRASIERER	461
METALLFUSSSTÜTZE	222	STRÄNKE	772
MIZELLARES WASSER	580	STREIFEN MECHAS	61-62
MÖBELEMPFANG	831	STÜHLE	223
MR. BEAR FAMILIE	509	STÜHLE FÜR KINDER	219-220
MYRSOL	L 512-515	STÜTZEN UND STATIV	215-573
MYRSOL-MASSAGEN	512,514-515	SYNTHETISCHE HAARKÖPFE	212-213
NAGELBEHANDLUNGEN POLLIÉ	651	TALK	477
NAGELKNIPPER	718	TASCHE MIT HAKEN FÜR RINGE	385
NAGELSCHNEIDEZANGE	711	TASCHENAUFHÄNGER	400
NAGELSCHNEIDEZANGE	716	TASCHENHAKEN MECHAS	350
NAIL ART ZUBEHÖR	663-673	TIMER	62
NATURHAAR SCHAUFENSTERPUPPE KOPF	207-209	TITAN UND VERZIERTE SCHERE	359-360
NIEDRIGE SKINS	724	TRAGBARE WASCHMASCHINEN	238-239
ÖLE	436	TRAGEN	823-826
ORGANISATOR (LEER)	399	TRIBÜNE	139-141
OSMA	511	TRIEBWERKE	720
OVALER PROFESSIONELLER PINSEL	259	TROCKENEFFEKT-FIXIERUNG	502
PACKKAPITÄN KOCH	429	TROCKNER	9-24,438-440
PAPILLOTS	335	TROCKNERHALTER	25
PARAFFIN	679	TURBANT	199
PEGASUS-KÄMME	304	UNSICHTBARE NETZWERKE	352
PERMANENTES PAPIER	204-205	UV-STRAHLENSCHUTZ	817
PERÜCKENHALTER	401	VEREDELUNGSPRODUKTE	158-167
PINSEL UND MAKE-UP-PINSEL	749-751,754	VIBRATORISCHER MASSAGESTOCK	607
PINSELANZEIGEN	268,270-271	VITALISIERENDE HAARLOTION	515
PLATTEN	35-45	VOLLE WIMPERN ANDREA	770-771
POLITURENTFERNER	658-660	WAAGE	62-63
POLLIE HAARENTFERNUNGSKITS	630	WACHE	81
POLLIE EINWEG-TASCHENMESSER	377	WACHS	615-616
POLLIE HÖLZERNER AUGENSTIFT	738	WACHS FORMAT ROLL-ON	624-627
POLLIE MAKEUP PINSEL	748	WACHSBÄNDER	631-633
POLLIE TASCHENMESSER FÜR AUGENBRAUEN	775	WACHSFORMAT KG	611-614
POLLIE-EMAILLE	647-651	WACHSKAPITÄN COOK	505
POLLIE-WIMPERN	763-766	WAGEN	240-242
PRODUKTLINIE MAT, RECYCLT	327-329	WAGEN UND TROMMEL	532
PROFESSIONELLE KÄMME POLLIÉ	305-306	WÄRMEBÜRSTE	286
PROFESSIONELLE SCHERE	361-365,367-372	WÄRMEBÜRSTEN	283-284
PROFESSIONELLES TASSEL-DISPLAY	588	WASCHBECKEN UND WASCHBECKENABDECKUNGEN	74
PROTEKTOREN	80.567	WASSERDURCHFLOSSREDUZIERER	245.537
PROTEKTOREN UND HANDSCHUHE	781-783	WERKZEUGHALTER AUS SILIKON	399
QUASTE	517-519	WERKZEUGHALTERRIEMEN	398
RAGNAR 360° REPARATURMASCHINEN	430	WIEDERAUFLADBARE FARBMISCHER	53
RAGNAR REPARATURMASCHINEN	426	WIMPERN ANDREA SM	769
RAGNAR RASIERER	432	WIMPERN-KITS	772
RAGNAR BARTBÜRSTE	478	WIMPERN-DISPLAY ANDREA	774
RAGNAR TASCHENMESSER	447-448	WIMPERNKLEBSTOFFE	773
RAGNAR-BÜRSTEN	479	WIMPERNSET ANDREA STARTER	771
RAGNAR-KÄMME	485-488	WIMPERNSTRÄNKE OHNE KNOTEN	771
RAGNAR-PINSEL	481	WURZEL-TOUCH-UP-RAGNAR	497
RASIERER	638-639	ZÄHLER UND SPIEGEL	217-218
RASIERMESSERSCHERE	366	ZANGE	181-187
RASIERMULSION OHNE ALKOHOL	513	ZANGE FÜR VERLÄNGERUNGEN	385
RASIERERSCHAUM	461	ZANGE PINZETTE	640-645
RASIERSEIFE BADEZIMMER	476	ZEIGT ÄTHERISCHE ÖLE	591
REIHE DER IONISCHEN BÜRSTEN	281	ZEIGT CAPTAIN COOK	506
REINIGUNG UND HYGIENE	405-408	ZELLULOSE- UND SPUNLACE-TÜCHER	203
REINIGUNGSBÜRSTE-KÄMME	495	ZUBEHÖR	817
REINIGUNGSMILCH	579	ZUBEHÖR FÜR DREHMASCHINEN	685
REVITALISIERENDES TONIC	579	ZUBEHÖR TÖNUNG	59-60
RINGE	382	ZUBEHÖR UND KITS POLLIÉ	652
ROBEN UND KIMONOS	102	ZUBEHÖR WACHS	622-623
ROCK CURLS CREME	503	ZYLINDER FÜR BÜRSTEN UND BÜRSTEN	747
ROLL-ON WAX MEN	519		
ROLL-ON-WACHS-ZUBEHÖR	628-629		
ROLLE KÄLTVEVERBÄNDE	608		
ROLLEN	336-343		
SALBE DIE LEGENDEN	516		
SAUGNAPFAUFHÄNGER	839		
SCHAUFENSTERPUPPE KÖPFE BARBER LINE	572		
SCHAUFENSTERPUPPE KÖPFE BERGMANN	214		

ABBIGLIAMENTO MASCHILE LACLA	548-551	ESPOSITORE CIGLIA ANDRE	774
ABBIGLIAMENTO/DIVISE LACLA	802-807	ESPOSITORE FORBICI	377
ABITI E KIMONO	102	ESPOSITORE IN LEGNO 20 SPAZZOLE	254
ACCESSORI	817	ESPOSITORE RITOCO RADICI RAGNAR	497
ACCESSORI CERA	622-623	ESPOSITORI	740
ACCESSORI CERA ROLL-ON	628-629	ESPOSITORI A SPAZZOLA	268,270-271
ACCESSORI COSMETICI	609	ESPOSITORI OLI ESSENZIALI	591
ACCESSORI COSMETICI	680	ESPOSIZIONE FIBRE CAPELLI	519
ACCESSORI E KIT POLLIE	652	ESPOSIZIONE NAPPA PROFESSIONALE	588
ACCESSORI MANICURE	721	ESSICCATORE CASCO ORLA	33
ACCESSORI NAIL ART	663-673	ESSICCATORE TRIANGOLARE RETE	345
ACCESSORI PER TORNIO	685	ESSICCATORI	9-24,438-440
ACCESSORI TINTA	59-60	ESSICCATORI PER CASCHI	30-31
ACCONCIATURE E MANTELLE	542	ESTENSIONI DEL CAMPIONE DI COLORE	385
ACQUA MICELLARE	580	EUROSTIL MACCHINE DA TAGLIO	424
ADESIVI CIGLIA	773	EUROSTIL MACCHINE DA TAGLIO	424-425
ADESIVO PER FISSARE TENDA PER CAPELLI	384	EUROSTIL MACCHINE PER RITOCO	425
AGHI ELETTRICI	636	EUROSTIL COLTELLI	455
ANDREA CIGLIA	767-768	EUROSTIL PETTINI	492
ANDREA SOPRACCIGLIA	775	EYELINER	741
ANELLI	382		
ANELLO LUCE LED	808-809	FASCE CERETTA	631-633
ANTICELLULITE E RASSODANTE	605	FIBRE CAPELLI	164-518
ASCIUGA CASCO VALERA	34	FILO DI CIGLIA SENZA NOD	772
ASCIUGAMANI	404.558-559,784	FIOCCO IMBOTTITO	771
ASCIUGAMANI IN CELLULOSA E SPUNLACE	203	FISSAGGIO EFFETTO SECCO	353-357
ASCIUGAMANI SPUNLACE	204,780-781	FLACONI APPLICATORI GRADUATI	502
ASPIRAPOLVERE	57,442	FOGLIA DI ALLUMINIO	76
ATOMIZZATORE A FIBRA CAPILLARE	518	FORBICI A BORDO DI RASOIO	77-79
ATTIVATORI	28-29	FORBICI CAPITANO CUOCO	366
		FORBICI EUROSTIL	466-468
BALSAMO DA BARBA	509	FORBICI INIZIATIVE	470-471
BALSAMO PER BAFFI	509	FORBICI LINEA BARBER	372-472
BANCHI DI RICEVIMENTO E ALTR	533-534	FORBICI LINEA MANCINI	373
BANCHI E SPECCHI	217-218	FORBICI PER PELLE E UNGHIE	463,469
BARBER LINE RASOIO	433	FORBICI PROFESSIONALI	366
BARBER LINE SET DA RASATURA	478	FORBICI RAGNAR	722-723
BARELLE	823-826	FORBICI SPECIALI DELL'ACCADEMIA	361-365,367-372
BASTONE DA MASSAGGIO VIBRANTE	607	FORBICI SPECIALI PER MANCINI	464-465
BIGODINI IN LEGNO	331	FORCHE	373
BIGODINI IN PLASTICA	332-334	FORMATO CERA KG	473
BLEACHER	139-141	FORMATO CERA ROLL-ON	175-180
BLISTER DI PREVENZIONE CADUTA	517	FRUSTA IN ACETATO COMB	611-614
BOLE	64-67	FUSORI	624-627
BORSA APPLICATORI OMBRETTI	759		324
BORSA DISCO PER ESTENSIONI	385		617-620
BORSA UNCINETTO	350		
		GANCI PER BORSE MECHAS	350
CAPELLI PER BAMBINI	104-105	GANCIO A VENTOSA	839
CAPELLI SINTETICI	212-213	GANCIO PETTINE METALLICO MECHAS	350
CAPITANO BARBERSHOP MAT	437	GARZA ASTRINGENTE PELLI LINE	590
CAPITANO COOK TAGLIO CAPO	547	GEL ACRILICO	656-657
CAPITANO CUOCO	498-504	GEL ELETTROCONDUTTIVO	637
CAPS	344.346-349,351	GEL LE LEGGENDE	516
CAPTAIN COOK RASOIO	434	GOMME E CRAVATTE	192-198
CAPTAIN COOK OLI	505	GRAFFI	189-191
CAPTAIN COOK CREMA	499	GRANDI FUSITORI	621
CAPTAIN COOK CREME	505	GRAVITY POLVERE VOLUMINIZZANTE	504
CAPTAIN COOK PETTINI	489-490	GREMBIULE CAPITANO CUOCO	547
CAPTAIN COOK UNGUENTI	500-502	GREMBIULE LINEA BARBIERE	546
CARRELLI	240-242	GREMBIULE PER SPAZZOLE E SPAZZOLE	747
CARRELLI E FUSTI	532	GREMBIULI	103
CARRELLO MANICURE/PEDICURE	830	GUANTI	1 81-83
CARTA COLLO	539-540	GUANTI E ACCESSORI	560-561
CARTA PERMANENTE	204-205	GUARDIA	81
CARTELLE E SEDIE TRUCCO	837-838		
CASI	556-557,810-815	IGIENE E DISINFETTANTI	1 818-821
CASSA FORBICI	374-376	IRRIGATORI	68-73
CERA	615-616		
CERA CAPITANO CUOCO	505	KIMONO ANTISTATICO	117
CERA ROLL-ON UOMO	519	KIT ARRICCIA CAPELLI	339
CEROTTI VAPOORIZZATORI	32	KIT CIGLI	772
CIGLIA ANDREA SIM	769	KIT CIGLIA ANDREA STARTER	771
CIGLIA COMPLETE ANDREA	770-771	KIT ESFOLIANTE CORPO/VISO	604
CIGLIA POLLIE	763-766	KIT ESTENSIONE	385
CILINDRO PER SPAZZOLE E SPAZZOLE	747		
CINGHIA PORTA UTENSILI	398	LA RASATURA CO	507-508,510
CLIP	169-173,383	LABBRA IN LEGNO A MATITA POLLIE	739
CLIP CON PERLE	200-201	LACCA FIBRE CAPELLI	519
CLIP E FORCHE	174	LACCI CAPTAIN COOK	503
CLIP E MORSETTI	188	LACLA MASCHERE VISO	801
COLORE LUMINOSO	121-132	LACLA CASACAS	107-110
COLTELLI DA TASCA CAPITANO CUOCO	453-454	LAME	457-459
COLTELLI DA TASCA E LAME IN PIUMA	456	LAMPADA DA TAVOLO MANICURE	830
COLTELLI DA TASCA MONOUSO POLLIE	377	LAMPADA	673-678
COLTELLI DA TASCA RAGNAR	447-448	LATTE DETERGENTE	579
COLTELLI LINEA BARBER	449-452	LAVABI E COPRI LAVABO	74
COLTELLI MONOUSO	460	LAVABO DOCCIA NERO	244,536
COLTELLI PER SOPRACCIGLIA POLLIE	775	LAVATESTA	224-229,527-528
CONTENITORE ASCIUGAMANI	535,839	LE LEGGENDE	516
CONTENITORE PER FORBICI	377	LEVA SINGOLA PER LAVACESAS	243,535
COPERTINE E TENDA CARTA	777	LIME E BLOCCHI PER LUCIDATURA	692-708
COPERTURE E ASCIUGAMANI	778-779	LINEA ARGAN	146
COPERTURE PER TAGLIO UNGHIE E GOGGING	719	LINEA BARBER FUSORE CERA NERA	441
COSMETICI POST DEPILAZIONE	634-635	LINEA BARBIERE FERRO PICCOLO	441
COTONE	387,791-792	LINEA COSMETICA IALURONICA	581-582
CREMA MANI	660	LINEA DI SPAZZOLE IONICHE	281
CREMA PER RICCI DI ROCCA	503	LINEA PRODOTTO MAT. RICCLATO	327-329
CREME E TRATTAMENTI	583-585,587,589	LINEA SENSAZIONE AROMA	149-152
CUSCINI SPECIALI BAMBINI	220,530	LIIQUIDO TRATTAMENTO BENDAGGIO FREDDO	608
		LOUPES	690-691
DIFFUSORI	26-27	LOZIONE IDRATANTE CORPO LATTE	606
DISINFETTANTE, STERILIZZATORI	563-565	LOZIONE VITALIZZANTE PER CAPELLI	515
DISPENSER A PETTINE ONE USE	297		
DISPENSER GEL	568	MACCHINE DA TAGLIO CAPTAIN COOK	422-423
DISPLAY NAPPA CELLE ATTIVE	586	MACCHINE DA TAGLIO RAGNAR	416-421
DISTRIBUTORI	409	MACCHINE PER RITOCO CAPTAIN COOK	427-428,431
DOCCIA CON SUPPORTO	243,535	MANICHINO CAPELLI NATURALI TESTA	207-209
DOCCIA CON SUPPORTO LAVACAEZAS	244,536	MANICHINO UOMO CAPELLI NATURALI	210-211
DOPO BARBA MYRSOL	513	MANICO PER SCOPA	410
DOPO BARBA SPLASH	508	MANPE MONOUSO	86-89
		MASCARA	741
ELICHE	720	MASCHERA IALURONICA	144
EMULSIONE DA BARBA SENZA ALCOOL	513	MASCHERA NERA PULIZIA PROFONDA	580
EROGATORE	80	MASCHERA VISO	596
ESFOLIANTE VISO	580	MASCHERE VISO	800

MASSAGGI MYRSOL		SCHERMO VISO FACEPRO	399
MATITA OCCHI IN LEGNO POLLIE	512,514-515	SCHIUMA DA BARBA	461
MATITA SOPRACCIGLIA IN LEGNO POLLIE	738	SCOPE	569
MATITE IN PLASTICA POLLIE	740	SCOPE DI GOMMA	410
MIXER RICARICABILE DI COLORE	737	SCRUB CORPO	604
MOBILI COMPLEMENTARI	53	SCUDO VISO	400
MORSETTO IN ACCIAIO INOX. USO GENERALE	827	SEDIA SPECIALE PER BAMBINI	530
MR.BEAR FAMIGLIA	784	SEDIE	223
MYRSOL	509	SEDIE DA BARBIERE	230-232,234-237
	12-515	SEDIE PER BAMBINI	219-220
NAPPA	517-519	SEDIE PER BAMBINI	529
OCCHIALI PROTETTIVI ANTIAPPANNAMENTO		SEPARATORI PER CAPELLI	541
OLI	791	SET DOCCIA ADATTABILE	243.535
OLI BASE	436	SET MONOCOMANDO E DOCCIA	536
OLI ESSENZIALI	601-603	SGABELLI	221-222
OLIO DA BARBA	592-595	SGABELLI, SEDIE E SUPPORTI	832-836
OSMA	509	SHAKER DA COCKTAIL E METRI	75
OSSIDANTE CAPILLARE	511	SHAMPOO	141,146-147,153-154
	132-135	SHAMPOO AL BOURBON	874 504
PACCHETTO BARBA CAPITANO CUOCO	504	SHAMPOO CAPITANO CUOCO	498
PACCHETTO CAPTAIN COOK	504	SHAMPOO CAPITANO CUOCO	499
PACK CAPTAIN COOK	429	SHAMPOO E MASCHERE	142-143,145,155-157
PANTALONE LACLA	118-119	SHAMPOO IALURONICO	144
PAPILLOTT	335	SHAMPOO PREVENZIONE CADUTA CAPELLI	517
PARAFFINA	679	SILKOMB PETTINI PROFESSIONALI	310
PARTITE EMOSTATICHE	516	SMALTO P-MANCANZA	653-655
PELLI BASSA	516	SMALTO POLLIE	647-651
PENNA RASOIO	724	SOFFIONE DOCCIA CROMATO	244.536
PENNELLI E PENNELLI PER IL TRUCCO	461	SOFFIONE DOCCIA IONICO	243.535
PENNELLI ESPOSITORI	749-751,754	SOLVENTI	394
PENNELLI PER TRUCCO POLLIE	758	SPAZZOLA A SOFFIETTO CON MANICO IN LEGNO	252
PENNELLO ANGOLATO	748	SPAZZOLA A SOFFIETTO CON MANICO IN PLASTICA	258-263
PETTINE COLORE LATTINE	747	SPAZZOLA A SOFFIETTO DISTRICANTI	257
PETTINE CON LIVELLI	315-319	SPAZZOLA CIRCOLARE	286
PETTINE DA BARBA SPECIALE	280.495	SPAZZOLA CIRCOLARE IN LEGNO	249-251
PETTINE ELETTRICO ANTIPIDOCCHI	478	SPAZZOLA CIRCOLARE IN PLASTICA	249
PETTINE PROFESSIONALI EUROSTIL	52	SPAZZOLA DA BARBA RAGNAR	478
PETTINE SFILANTE IN LEGNO	287-296,298	SPAZZOLA DISTRUTTRICE	267
PETTINE SPECIALE STOPPINI	324	SPAZZOLA ELETTRICA TERMICA	52
PETTINI	350	SPAZZOLA IN LEGNO CON MANICO IN GOMMA	252
PETTINI	302-303	SPAZZOLA LINEA BARBER	479
PETTINI ANONIMI	84-85	SPAZZOLA PER SHAMPOO MASSAGGIATORE	315
PETTINI COLOR LEGNO	301	SPAZZOLA PROFESSIONALE OVALE	259
PETTINI DA BARBIERE LINEA	320-321	SPAZZOLA RAGNAR	481
PETTINI IN ACETATO	491	SPAZZOLA SFERICA 3D	269
PETTINI IN CARBONIO	325-326	SPAZZOLA TERMICA	286
PETTINI LENDRE/SPAZZOLE PER NEONATI	299-300.493	SPAZZOLE	476
PETTINI PEGASUS	279	SPAZZOLE	759
PETTINI PER GETTARE	304	SPAZZOLE	784
PETTINI PER LA PULIZIA	322-323	SPAZZOLE A SOFFIETTO CON MANICO IN GOMMA	264-265
PETTINI PROFESSIONALI MATADOR	495	SPAZZOLE A SOFFIETTO CON MANICO IN LEGNO	253-254,256
PETTINI PROFESSIONALI POLLIE	307-309	SPAZZOLE A SPIRALE	248
PETTINI RAGNAR	305-306	SPAZZOLE CON MANICO IN LEGNO	755-757
PETTINI SILKOMB	485-488	SPAZZOLE DA BARBIERE	475
PETTINI VARI COLORI	494	SPAZZOLE EUROSTIL	482-483
PINZE	311-314	SPAZZOLE GEL E ACRILICHE	661-662
PINZE ARRICCIANT	181-187	SPAZZOLE IN BAMBÙ	255
PINZE PER PROLUNGHE	46-51	SPAZZOLE KABUKI	752-753
PINZE PER TAGLIO CUTICOLE	385	SPAZZOLE LINEA BARBER	480-481
PINZE PER TAGLIO UNGHIE	712-715,717	SPAZZOLE PER CREPE	247
PINZE PER TAGLIO UNGHIE	711	SPAZZOLE PER FERRO	278
PINZE PINZE	716	SPAZZOLE PIATTE DISTRANGENTI	277
PINZE TAGLIO CUTICOLE	640-645	SPAZZOLE PNEUMATICHE	266
POGGIAPIEDI IN METALLO	711	SPAZZOLE RAGNAR	479
POLLIE 630 KIT DEPILAZIONE	222	SPAZZOLE SCHELETRO	272-276
POLO DA BARBIERE	630	SPAZZOLE TERMICHE	283-284
POLTRONA DA BARBIERE	521	SPAZZOLE TERMICHE IN ALLUMINIO	285
POLTRONE PER PARRUCCHIERE	522-526	SPAZZOLE TERMICHE IN CERAMICA	282
PORTA ASCIUGAMANI	233	SPAZZOLE TERMICHE IONICHE	282
PORTA ASCIUGAMANI	243	SPECCHI	400.531.566.793-799
PORTA ASCIUGAMANI	535	SPECIFICHE PEDICURE	725-735
PORTA CARTE DA COLLO	839	SPRUZZATORI	401-403.552-555.816
PORTA CARTE IN ALLUMINIO	541	SPUGNE DI KONJAC	599
PORTA ESSICCATORE	400	SPUGNE STRUCCANTI	742-743
PORTA PARRUCCA	25	SPUGNE TRUCCO	744-746
PORTA PENNELLI TRUCCO	401	STERILIZZATORI	54-56,443-445,709-710
PORTA SACCHETTI	760-761	STOLE LACLA	111-117
PORTA UTENSILI IN SILICONE	400	STRATI	90-101,543-545
PORTA UTENSILI NERO	399	STRISCE MECHAS	61-62
PRODOTTI PER LA FINITURA	397	SUPPORTI E TREPPIEDE	215.573
PROLUNGHE PINZE PER SALDARE	158-167	SUPPORTO MAGNETICO PER IL POLSO	181
PROTEZIONE DELL'ORECCHIO	53		
PROTEZIONI	541	TAGLIA CAPELLI	377
PROTEZIONI E GUANTI	80.567	TAGLIA CAPELLI E RASOIO	378-379
PROTEZIONI OCULARI	781-783	TAGLIA UNGHIE	E 718
PROTEZIONI RAGGI UV	541	TAGLIA UNGHIE ARTIFICIALI	718
PULITORE PER SPAZZOLE IN SILICONE	817	TALCO	477
PULIZIA E IGIENE	760	TAPPETO DA BARBIERE RAGNAR	437
	405-408	TAPPETO DISINFEZIONE CALZATURE	791
RAGNAR 360° MACCHINE PER RITOCOCCO	430	TARGHE	35-45
RAGNAR MACCHINE PER RITOCOCCO	426	TAVOLI PER MANICURE	T 828-829
RAGNAR RASOIO	432 R	TEMPERAMATITE	759
RASOI	638-639	TENDE PER CAPELLI	381
RECEPTION MOBILI	831	TESTE DI MANICHINO BARBER LINE	572
RETI INVISIBILI	352	TESTE DI MANICHINO BERGMANN	214
RICAMBI PER TORNII	688-689	TESTE DI MANICHINO EUROSTIL	571-572
RICAMBI TORNII	684	TIMER	62
RICAMBI TORNII MANICURE	683	TINTURA PER CAPELLI	136-138
RICCI CIGLIA	774	TITANIO E FORBICI DECORATE	359-360
RICCI CIGLIA IN GOMMA DI RICAMBIO	774	TITOLARE	562
RIDUTTORE DI FLUSSO D'ACQUA	245.537	TONICO RIVITALIZZANTE	579
RIMOZIONE LUCIDO	658-660	TORNII	681-682,686-687
RITOCOCCO RADICE RAGNAR	497	TRATTAMENTI UNGHIE POLLIE	651
RONDELLE PORTATILI	238-239	TUBO DI SCARICO RONDELLA	245.537
ROTOLO BENDAGGI A FREDDO	608	TUBO DOCCIA FLESSIBILE IN NYLON	245.537
RULLI	336-343	TUBO DOCCIA FLESSIBILE IN PVC	245.537
		TURBANTI	199
SACCHETTO DI GANCI PER ANELLI	385	UGELLI EUROSTIL	435
SACCHETTO DI PROLUNGHE CLIP	384	UNGUENTO LE LEGGENDE	516
SACCHETTO PER SPIEDINI	343	UNITA DI LAVAGGIO MONOCOMANDO	244
SAPONE DA BARBA BAGNO	476	USO SINGOLO	785-791
SCALA IN LEGNO SPA	826	VALIGIE E BORSE	388-396
SCALE	62-63	VALVOLA LAVABO LAVAVETE	244.536
SCATOLA ORGANIZZATIVA (VUOTA)	399	VAPORI E ACCESSORI	597-598
SCATOLA SPIEDINI	343	VAPORIZZATORE EUROSTIL	33
		VISUALIZZA CAPTAIN COOK	506



C/Ciudad de Asunción 56 · Barcelona 08030 (Spain)
Tel. +34 93 274 07 84
ventas@eurostil.com · export@eurostil.com