



2021

Besondere Friseur

SPECIALE PER PARRUCCHIERI

Pollié 

lacla 

Ondina 

ETI 

PEGASUS 

Leriotti 
MADE IN ITALY

TRAMUNTANA 

MEDITERRÁNEO 

SILK OMB 

BERGMANN
HAIR AND MORE... 

MATADOR
PROFESIONAL 

Valera 

REMINGTON 

01 Elektrogeräte Articoli elettrici 4

Trockner · <i>Asciugacapelli</i>	5
Diffusoren · <i>Diffusori</i>	18
Thermische Aktivatoren · <i>Caschi e lampade a termostimolazione</i>	20
Haubentrockner, Dampfhaube Cerotti <i>Casco asciugacapelli, Vaporizzatore Cerotti</i>	21
Haubentrockner, Dampfhaube Eurostil <i>Casco asciugacapelli, Vaporizzatore Eurostil</i>	23
Valera Haubentrockner · <i>Casco asciugacapelli Valera</i>	24
Glätteisen · <i>Piastre</i>	25
Lockenstäbe · <i>Arriciacapelli</i>	35
Farbstoffmischer · <i>Miscelatore per tintura</i>	41
Sterilisatoren · <i>Sterilizzatori</i>	42
Staubsauger · <i>Aspiratore</i>	44
Kämme und Bürstenreineriger <i>Detergente per pettini e spazzole</i>	45

02 Färbemittel Articoli per la tintura 46

Färberei-Zubehör · <i>Accessori colore</i>	47
Dochtstreifen · <i>Fogli termici per mèches</i>	49
Zeitschaltuhr · <i>Timer</i>	50
Wagen · <i>Bilance</i>	51
Färbeschüssel · <i>Vaschette tintura</i>	52
Kleine Färbepinsel · <i>Panello per tintura</i>	56
Nackenschutz und Schutz für Waschbecken <i>Lavatesta e protettori per lavatesta</i>	61
Misch und Messbecher · <i>Shaker e misurini</i>	62
Aluminiumfolie · <i>Foglio di alluminio</i>	64
Schutzbeutel · <i>Protettori</i>	66
Handschuhe · <i>Guanti</i>	67
Gummi Nackenumhang · <i>Coprispalle</i>	70
Einweg Umhänge · <i>Mantelline monouso</i>	71
Delantales · <i>Grembiuli</i>	84
Kinder-Umhänge · <i>Mantelline bambino</i>	86
Umkleideraum LACLA · <i>Abbigliamento LACLA</i>	88

03 Haarkosmetik Cosmetici per capelli 102

Bright Colour Farbstoffe · <i>Tinta per capelli BRIGHT.COLOUR</i>	103
Oxidierende OXY BRIGHT · <i>OXY BRIGHT ossidante</i>	110
Haarfärbemittel · <i>Tinta per capelli</i>	112
Bleichpulver · <i>Decolorante</i>	114
Behandlung IONI-K · <i>Trattamento ONI-K</i>	116
Shampoo, Haar-Kur · <i>Shampoo, Maschera capillare</i>	119
Veredelungsprodukte, Haarfasern <i>Prodotti di finitura, Fibre capillari</i>	125

04 Spangen und klammern Clip e fermagli 134

Steckklammern · <i>Mollette</i>	135
Haarklammer und Haarnadeln · <i>Forcine e mollette</i>	139
Haarklammern · <i>Pinzette</i>	146
Metall Haarpangen · <i>Fermagli in metallo</i>	150
Haargummis · <i>Elastici</i>	155
Turban · <i>Turbanti</i>	159
Haarnadeln mit Perlen · <i>Fermagli con perle</i>	160

05 Papier Carta 162

Handtücher und Schutz <i>Tovaglioli e protettori</i>	163
Dauerwellen Papier · <i>Carta permanente</i>	164
Kreppansatzpapier für den Hals · <i>Carta da collo</i>	165

06 Ausbildung Formazione 166

Schaufensterpuppen-Kopf, NATURHAAR · <i>Teste studio, capelli naturali</i>	167
Schaufensterpuppenköpfe SYNTHETISCHES <i>Teste studio, capelli sintetici</i>	172
BERGMANN-Trainingköpfe <i>Teste studio bergmann</i>	173
Halterungen · <i>Supporti</i>	175

07 Möbel Complementi d'arredo 176

Theken und Spiegel · <i>Banconi e specchi</i>	177
Friseurstühle für Kinder · <i>Poltrone da parrucchiere per bambini</i>	179
Hocker · <i>Sgabelli</i>	181
Friseurstühle · <i>Poltrone</i>	183
Kopfwaschanlage · <i>Poltrona lavatesta</i>	184
Friseurstuhl <i>Poltrona da parrucchiere</i>	190
Tragbare Kopfwaschanlagen · <i>Lavatesta portatile</i>	196
Arbeitswagen · <i>Carrelli</i>	197
Verschiedenes · <i>Vari</i>	201

08 Kämme und bürsten Pettini e spazzole 202

Kreppbürste · <i>Spazzola per cotonare</i>	203
Bürste · <i>Spazzole</i>	204
Rundholzbürste	205
<i>Spazzole circolare</i>	
Bürste mit Balg und Holzgriff	209
<i>Spazzole pneumatiche con manico in legno</i>	
Bürste mit Balg und Kunststoffgriff	213
<i>Spazzole pneumatiche, districanti</i>	
Bürste mit Balg und Kunststoffgriff	214
<i>Spazzole pneumatiche con manico in plastica</i>	
Bürste mit Balg und Gummigriff	220
<i>Spazzole pneumatiche con manico in gomma</i>	
Entwirrende Bürste · <i>Spazzole districante</i>	223
Aussteller Entwirrende · <i>Espositore Spazzole</i>	224
Farbige Skelettbürsten · <i>Spazzole scheletro colorata</i>	228
Flache Bürsten zum Entwirren · <i>Spazzole piatte per districare</i>	233
Baby-Bürsten · <i>Spazzole baby</i>	234
Wärmebürste	236
<i>Spazzola termica</i>	
Professionelle Kämme · <i>Pettini professionali</i>	242
Kämme aus carbon · <i>Pettini in CARBONIO</i>	254
Set Kämme Eurostil · <i>Eurostil set pettini</i>	257
Professionelle PEGASUS-Kämme · <i>Pettini professionali PEGASUS</i>	259
Professionelle Pollié-Kämme · <i>Pettini professionali</i>	260
Professionelle MATADOR-Kämme · <i>MATADOR Pettini professionali</i>	262
Silkomb Profi-Kämme · <i>Pettini professionali Silkomb</i>	265
Farbige Kämme · <i>Pettini colorati</i>	266
Dose mit farbigen Kämmen · <i>Pettini colorati</i>	270
Kämme Holzfarbe · <i>Pettini color legno</i>	275
Fingerkamm · <i>Pettine districante</i>	277
Muschel/Acetat-Kamm · <i>Pettine tartaruga/acetato</i>	279
Produktlinie aus recyceltem material <i>Linea di prodotti in materiale riciclato</i>	282

09**Lockenwickler, duttkissen
und kopfbedeckungen
Bigodini, cuffie e retine****284**

Dauerwellenwickler aus Holz · <i>Bigodini in legno</i>	285
Dauerwellenwickler aus Plastik · <i>Bigodini di plastica</i>	287
Schaumlockenwickler · <i>Bigodini flessibili</i>	289
Lockenwickler · <i>bigodini</i>	290
Haarnete · <i>Retine</i>	298
Duttkissen · <i>Ciambelle acconciatura</i>	307

11**Klebe-extensions undhaarteile
Extension adesive e retine****332**

Haarteil · <i>Extension</i>	333
Ringe · <i>Anelli</i>	334
Extensions mit Clip · <i>Extension con clip</i>	335
Vercchiedenes · <i>Varis</i>	336

10**Rasiermesser und haarschnei-
descheren · Rasoi e forbici****312**

Verzierte Profi-Scheren	313
<i>Forbici professionali</i>	
Scheren · <i>Forbici</i>	320
Schere für Linkshänder · <i>Forbici speciali per MANCINI</i>	
Professionelle Scheren · <i>Forbici professionali</i>	321
Schere special academy kunststoffgriff · <i>Forbici speciali studenti</i>	323
Professioneller Scherenkoffer · <i>Astucci per forbici professionali</i> ..	325
Haarschneidmesser und Rasierklingen	326
<i>Rasoi</i>	327

12**Verschiedenes
Vari****338**

Watte · <i>Cotone</i>	339
Koffer · <i>Valigie</i>	340
Friseurertasche · <i>Porta utensili</i>	348
Facepro · <i>Facepro</i>	350
Verschiedenes · <i>Vari</i>	351
Halter für Perücken · <i>Porta parrucca</i>	352
Sprühflasche · <i>Spruzzatori</i>	353
Handtücher · <i>Asciugamani</i>	355
Hygiene-Artikel · <i>Articoli per l'igiene</i>	356

Die in diesem Katalog aufgeführten Preise sind empfohlene Preise, Steuern nicht inbegriffen.
Die Preise gelten bis auf Tippfehler.
Industrias Oriol 1942, S.L. behält sich das Recht vor, Änderungen ohne vorherige Ankündigung
vorzunehmen.

*I prezzi indicati in questo catalogo sono prezzi consigliati, tasse escluse.
I prezzi saranno validi salvo errori tipografici.
Industrias Oriol 1942, S.L. si riserva il diritto di apportare modifiche senza preavviso.*

01

Elektrogeräte

ARTICOLI
ELETTRICI

*Föhne, Glätteisen, Lockenstab,
Thermische Aktivatoren, Trockenhaube...*

*Asciugacapelli, piastre, ferri arricciacapelli,
caschi e lampade a termostimolazione,
caschi asciugacapelli...*



Trockner CALIMA
Asciugacapelli CALIMA



NEW

REF. 07171/50

NEW

REF. 07171/70



18,6 cm



18,6 cm

- » Leistung: 2300 W
- » Professioneller AC Wechselstrommotor
- » Gewicht: 530 g
- » Luftdurchsatz 98 m³/h
- » 2 Geschwindigkeiten, 3 Temperaturen
- » Kaltluftstufe
- » 2 verstellbare Luftdüsen 62 und 70 mm
- » Abnehmbarer Filter aus Edelstahl
- » Kabel mit Ring zum Aufhängen
- » Niedriger Schallpegel: 80 dB
- » Spannung 220-240V~
- » Frequenz: 50/60 Hz
- » Super kompakt
- » Ion, Keramisch und Turmalin
- » Diffusorkompatibel: 04346/50

- » Potenza: 2300w
- » Motore AC professionale.
- » Peso: 530 gr.
- » Portata d'aria: 98 m³/h
- » 2 velocità, 3 temperature
- » Pulsante aria fredda.
- » 2 bocchette regolabili da 62 e 70 mm
- » Filtro estraibile in acciaio inossidabile
- » Cavo flessibile con anello per
- » Silenzioso: 80 Db
- » Voltaggio 220-240V~
- » Frequenza: 50/60 Hz
- » Super compatto
- » Ionico, Ceramica e Turmalina
- » Compatibile diffusore: 04346/50

Trockner FURIOUS COMPACT PLUS

Asciugacapelli FURIOUS COMPACT PLUS



Die Eurostil-Modelle Furious und Furious Plus stammen aus unserem Sortiment mit 2200W – Sie sind ideal für alle Profis, die einen vielseitigen und anspruchsvollen Haartrockner suchen.

Gli asciugacapelli Eurostil Furious e Furious Plus sono una gamma di asciugacapelli da 2200 W ideali per qualsiasi professionista alla ricerca di un asciugacapelli versatile che soddisfi le aspettative più esigenti.

- » Kompakter AC-Motor mit langer Lebensdauer
- » Gewicht: 494 gr
- » Luftdurchsatz: 84 m³/Stunde
- » 2 Geschwindigkeiten, 3 Temperaturen
- » Kaltluft-Knopf
- » 2 Düsen
- » Herausnehmbarer Filter
- » Sicherheitsthermostat
- » Kabel mit Ring zum Aufhängen
- » Spannung 220-240V~
- » Frequenz: 50/60 Hz
- » Lila Zierleiste
- » Kompatibel mit Diffusoren: 04346/50 - 01147

- » Potenza: 2200W.
- » Motore compatto di lunga durata AC
- » Peso: 494 gr.
- » Portata d'aria: 84 m³/ora
- » 2 velocità, 3 temperature
- » Pulsante aria fredda
- » 2 bocchette
- » Filtro rimovibile
- » Termostato di sicurezza
- » Cavo flessibile
- » Voltaggio 220-240V~
- » Frequenza: 50/60 Hz
- » Finitura viola
- » Compatibile con diffusori: 04346/50 - 01147



REF. 06474



FURIOUS-Trockner Asciugacapelli FURIOUS



REF. 04922



- » Leistung: 2200W
- » Kompakter AC-Motor mit langer Lebensdauer
- » Gewicht: 590 gr
- » Luftdurchsatz: 74 m³/Stunde
- » 2 Geschwindigkeiten, 3 Temperaturen
- » Kaltluft-Knopf
- » 2 Düsen: 1 breit, 1 schmal
- » Herausnehmbarer Filter
- » Sicherheitsthermostat
- » Kabel mit Ring zum Aufhängen
- » Spannung 220-240V~
- » Frequenz: 50 Hz
- » Silberne Zierleiste
- » Kompatibel mit Diffusoren: 04346/50 - 01147

- » Potenza: 2200W.
- » Motore compatto di lunga durata AC
- » Peso: 590 gr.
- » Portata d'aria: 74 m³/ora
- » 2 velocità, 3 temperature
- » Pulsante aria fredda
- » 2 bocchette: 1 largo, 1 stretto
- » Filtro rimovibile
- » Termostato di sicurezza
- » Cavo flessibile
- » Voltaggio 220-240V~
- » Frequenza: 50 Hz
- » Finitura argento
- » Compatibile con diffusori: 04346/50 - 01147



22,6 cm



Trockner Eurostil ZONDA

Asciugacapelli Eurostil ZONDA



Die Haartrockner EUROSTIL sind mit der dreifachen TECHNOLOGIE (Ionen, Keramik und Turmalin) ausgestattet. Sie sind ein unverzichtbares Werkzeug für Fachleute. Sie spenden Feuchtigkeit, Geschmeidigkeit und Glanz, sie trocknen schneller, haben eine antibakterielle Wirkung und beschützen die Haarwurzeln. Sie begünstigen, jede Art von Frisur, ob glatt, wellig oder voluminös, zu gestalten.

I nuovi asciugacapelli Eurostil dotati di TRIPLA TECNOLOGIA (ionica, ceramica e tormalina) sono uno strumento essenziale per i professionisti. Forniscono idratazione, morbidezza e lucentezza, asciugano più velocemente, hanno un effetto battericida e riducono l'invecchiamento della fibra capillare. Permettono di creare qualsiasi tipo di acconciatura: liscia, ondulata, voluminosa, ecc.

REF. 04993/53

REF. 04993/70



23,6 cm



23,6 cm

- » Leistung: 2400W
- » Kompakter AC-Motor mit langer Lebensdauer
- » Gewicht: 590 gr
- » Luftdurchsatz: 97 m³/Stunde
- » 2 Geschwindigkeiten, 3 Temperaturen
- » Fester Kaltluft-Knopf
- » 2 einstellbare Düsen von 62 mm und 70 mm
- » Herausnehmbarer Filter
- » Sicherheitsthermostat
- » Flexibles Kabel 3m mit Ring zum Aufhängen
- » Niedriger Geräuschpegel
- » Spannung 220-240V~
- » Frequenz: 50/60 Hz
- » Filter aus rostfreiem Stahl
- » Ion-, Keramik und Turmalin
- » Kompatibel mit Diffusoren: 04346/50 - 01147 - 03036/50

- » Potenza: 2400W.
- » Motore compatto di lunga durata AC
- » Peso: 590 gr.
- » Portata d'aria: 97 m³/ora
- » 2 velocità, 3 temperature
- » Pulsante aria fredda fisso
- » 2 bocchette regolabili da 62mm e 70mm
- » Filtro rimovibile
- » Termostato di sicurezza
- » Cavo flessibile 3m
- » Silenzioso
- » Voltaggio 220-240V~
- » Frequenza: 50/60 Hz
- » Filtro in acciaio inossidabile
- » Ionico, Ceramica e Tormalina
- » Compatibile con diffusori: 04346/50 - 01147 - 03036/50

WIND-Trockner Asciugacapelli WIND



Die mit TRIPLE TECHNOLOGY (ionisch, keramisch und Turmalin) ausgestatteten Windtrockner von Eurostil sind unverzichtbare Werkzeuge für Fachleute. Sie spenden Feuchtigkeit, Weichheit und Glanz, trocknen schneller, haben eine bakterizide Wirkung und reduzieren die Alterung der Haarfasern. Sie ermöglichen es, jede Art von Frisur zu kreieren: glatt, wellig, voluminös usw.

I nuovi asciugacapelli Wind di Eurostil dotati di TRIPLA TECNOLOGIA (ionica, ceramica e tormalina) sono uno strumento essenziale per i professionisti. Forniscono idratazione, morbidezza e lucentezza, asciugano più velocemente, hanno un effetto battericida e riducono l'invecchiamento della fibra capillare. Permettono di creare qualsiasi tipo di acconciatura: liscia, ondulata, voluminosa, ecc.



- » Leistung: 2300W
- » Kompakter AC-Motor mit langer Lebensdauer
- » Gewicht: 530 gr
- » Luftdurchsatz: 88 m³/Stunde
- » 2 Geschwindigkeiten, 3 Temperaturen
- » Kaltluft-Knopf
- » 2 einstellbare Düsen von 62 mm und 70 mm
- » Herausnehmbarer Filter
- » Sicherheitsthermostat
- » Flexibles Kabel 3m mit Ring zum Aufhängen
- » Niedriger Geräuschpegel
- » Spannung 220-240V~
- » Frequenz: 50/60 Hz
- » Mit Temperaturanzeigeleuchte
- » Filter aus rostfreiem Stahl
- » Kompatibel mit Diffusoren: 04346/50 - 01147 - 03036/50

- » Potenza: 2300W.
- » Motore compatto di lunga durata AC
- » Peso: 530 gr.
- » Portata d'aria: 88 m³/ora
- » 2 velocità, 3 temperature
- » Pulsante aria fredda
- » 2 bocchette regolabili da 62mm e 70mm
- » Filtro rimovibile
- » Termostato di sicurezza
- » Cavo flessibile 3m
- » Filtro in acciaio inossidabile
- » Silenzioso
- » Voltaggio 220-240V~
- » Frequenza: 50/60 Hz
- » Con spia della temperatura
- » Compatibile con diffusori: 04346/50 - 01147 - 03036/50



KOMPAKTER PROFESSIONAL trockner Asciugacapelli COMPACT PROFESSIONAL



Der Profi-Trockner Compact hat ein attraktives, ergonomisches und leichtes Design. Erhältlich in schwarz, weiß und weiß mit farbigen Gummi. Leistungsstarker Motor mit Ionengenerator. Enthält zwei Düsen unterschiedlicher Größe.

L'asciugacapelli professionale Compact ha un design accattivante, ergonomico e leggero. Disponibile in nero, bianco e bianco con guarnizioni colorate. Motore potente con generatore di ioni. Include due bocchette di dimensioni diverse.

NEW



REF. 04202

21,5 cm

- » Leistung: 2000W
- » Kompakter AC-Motor mit langer Lebensdauer
- » Gewicht: 580 gr
- » Luftdurchsatz: 90 m3/Stunde
- » 2 Geschwindigkeiten, 3 Temperaturen
- » Kaltluft-Knopf
- » 2 einstellbare Düsen von 62 mm und 70 mm
- » Herausnehmbarer Filter
- » Sicherheitsthermostat
- » Flexibles Kabel 3m mit Ring zum Aufhängen
- » Niedriger Geräuschpegel
- » Spannung 220-240V~
- » Frequenz: 50/60 Hz
- » Ergonomische Gestaltung
- » Robustes und leichtes Polyamid-Gehäuse
- » Anti-Rutsch-Gummibesatz
- » Ionengenerator-Motor
- » Kompatibel mit Diffusoren: 04346/50 - 01147 - 03036/50

- » Potenza: 2000W.
- » Motore compatto di lunga durata AC
- » Peso: 580 gr.
- » Portata d'aria: 90 m3/ora
- » 2 velocità, 3 temperature
- » Pulsante aria fredda
- » 2 bocchette regolabili da 62mm e 70mm
- » Filtro rimovibile
- » Termostato di sicurezza
- » Cavo flessibile 3m
- » Silenzioso
- » Voltaggio 220-240V~
- » Frequenza: 50/60 Hz
- » Design ergonomico
- » Corpo in poliammide robusto e leggero
- » Rivestimento in gomma antiscivolo
- » Motore generatore di ioni
- » Compatibile con diffusori: 04346/50 - 01147 - 03036/50



REF. 04202/58/99

KOMPAKTER EXTRA-LICHT-Trockner Asciugacapelli COMPACT EXTRA LIGHT



Der Profi-Trockner Compact hat ein attraktives, ergonomisches und leichtes Design. Erhältlich in schwarz, weiß und weiß mit farbigen Gummi. Leistungsstarker Motor mit Ionengenerator. Enthält zwei Düsen unterschiedlicher Größe.

L'asciugacapelli professionale Compact ha un design accattivante, ergonomico e leggero. Disponibile in nero, bianco e bianco con guarnizioni colorate. Motore potente con generatore di ioni. Include due bocchette di dimensioni diverse.



REF. 04203

21,5 cm



REF. 04203/58

21,5 cm



- » Leistung: 1800W
- » Gleichstrommotor
- » Gewicht: 430 gr
- » Luftdurchsatz: 76 m³/Stunde
- » 2 Geschwindigkeiten, 3 Temperaturen
- » Kaltluft-Knopf
- » 2 einstellbare Düsen von 62 mm und 70 mm
- » Herausnehmbarer Filter
- » Sicherheitsthermostat
- » Flexibles Kabel 3m mit Ring zum Aufhängen
- » Sehr niedriger Geräuschpegel
- » Spannung 220-240V~
- » Frequenz: 50/60 Hz.
- » Kompakt und LEICHTER
- » Anti-Rutsch-Gummibesatz
- » Mit Ionengenerator
- » Kompatibel mit Diffusoren: 04346/50 - 01147 - 03036/50

- » Potenza: 1800W.
- » Motore DC
- » Peso: 430 gr.
- » Portata d'aria: 76 m³/ora
- » 2 velocità, 3 temperature
- » Pulsante aria fredda
- » 2 bocchette regolabili da 62mm e 70mm
- » Filtro rimovibile
- » Termostato di sicurezza
- » Cavo flessibile 3m
- » Impatto acustico molto basso
- » Voltaggio 220-240V~
- » Frequenza: 50/60 Hz
- » Compatto e PIÙ LEGGERO
- » Rivestimento in gomma antiscivolo
- » Motore potente con generatore di ioni.
- » Compatibile con diffusori: 04346/50 - 01147 - 03036/50



REF. 04203/58/99

Trockner NEO 3800 Asciugacapelli NEO 3800

NEO3800
PROFESSIONAL



REF. 03323

- » Leistung: 2000W
- » Kompakter AC-Motor mit langer Lebensdauer
- » Gewicht: 590 gr
- » Luftdurchsatz: 84 m3/Stunde
- » 2 Geschwindigkeiten, 3 Temperaturen
- » Kaltluft-Knopf
- » 2 einstellbare Düsen 63 mm und 72 mm
- » Herausnehmbarer Filter
- » Sicherheitsthermostat
- » Flexibles Kabel 3m mit Ring zum Aufhängen
- » Spannung 220-240V~
- » Frequenz: 50/60 Hz
- » Thermischer Schutz
- » Kompatibel mit Diffusoren: 04346/50 - 01147 - 03036/50

- » Potenza: 2000W.
- » Motore compatto di lunga durata AC
- » Peso: 590 gr
- » Portata d'aria: 84 m3/ora
- » 2 velocità, 3 temperature
- » Pulsante aria fredda
- » 2 bocchette regolabili da 63 mm e 72mm
- » Filtro rimovibile
- » Termostato di sicurezza
- » Cavo flessibile 3m
- » Voltaggio 220-240V~
- » Frequenza: 50/60 Hz
- » Protezione termica
- » Compatibile con diffusori: 04346/50 - 01147 - 03036/50



Trockner NEO 3830 Asciugacapelli NEO 3830

ionic NEO 3830
PROFESSIONAL



REF. 03904

- » Leistung: 2000W
- » Kompakter AC-Motor mit langer Lebensdauer
- » Gewicht: 590 gr
- » Luftdurchsatz: 82 m3/Stunde
- » 2 Geschwindigkeiten, 3 Temperaturen
- » Kaltluft-Knopf
- » 2 einstellbare Düsen 62 mm und 70 mm
- » Herausnehmbarer Filter
- » Sicherheitsthermostat
- » Flexibles Kabel 3m mit Ring zum Aufhängen
- » Spannung 220-240V~
- » Frequenz: 50/60 Hz
- » Mit Turmalin und ionischen
- » Thermischer Schutz
- » Kompatibel mit Diffusoren: 04346/50 - 01147 - 03036/50

- » Potenza: 2000W.
- » Motore compatto di lunga durata AC
- » Peso: 590 gr.
- » Portata d'aria: 82 m3/ora
- » 2 velocità, 3 temperature
- » Pulsante aria fredda
- » 2 bocchette regolabili da 62mm e 70mm
- » Filtro rimovibile
- » Termostato di sicurezza
- » Cavo flessibile 3m
- » Voltaggio 220-240V~
- » Frequenza: 50/60 Hz
- » Con tormalina e ionico
- » Protezione termica
- » Compatibile con diffusori: 04346/50 - 01147 - 03036/50



Trockner NEO 3820 Asciugacapelli NEO 3820

ionic NEO 3820
PROFESSIONAL



REF. 03905

- » Leistung: 2000W
- » Kompakter AC-Motor mit langer Lebensdauer
- » Gewicht: 585 gr
- » Luftdurchsatz: 79 m3/Stunde
- » 2 Geschwindigkeiten, 3 Temperaturen
- » Kaltluft-Knopf
- » 2 Düsen: 1 breit, 1 schmal
- » Herausnehmbarer Filter
- » Sicherheitsthermostat
- » Flexibles Kabel 3m mit Ring zum Aufhängen
- » Spannung 220-240V~
- » Frequenz: 50/60 Hz
- » Turmalin und Ionengenerator
- » 1 Diffusor

- » Potenza: 2000W.
- » Motore compatto di lunga durata AC
- » Peso: 585 gr.
- » Portata d'aria: 79 m3/ora
- » 2 velocità, 3 temperature
- » Pulsante aria fredda
- » 2 bocchette: 1 largo, 1 stretto
- » Filtro rimovibile
- » Termostato di sicurezza
- » Cavo flessibile 3m
- » Voltaggio 220-240V~
- » Frequenza: 50/60 Hz
- » Con tormalina e ionico
- » 1 diffusore



Trockner NEO 3840 Asciugacapelli NEO 3840

ionic NEO 3840
PROFESSIONAL



REF. 04363

- » Leistung: 2200W
- » Kompakter AC-Motor mit langer Lebensdauer
- » Gewicht: 590 gr
- » Luftdurchsatz: 83 m3/Stunde
- » 2 Geschwindigkeiten, 3 Temperaturen
- » Kaltluft-Knopf
- » 2 einstellbare Düsen: 1 breit, 1 schmal
- » Herausnehmbarer Filter
- » Sicherheitsthermostat
- » Flexibles Kabel 3m mit Ring zum Aufhängen
- » Spannung 220-240V~
- » Frequenz: 50/60 Hz
- » Ergonomische Gestaltung
- » Robustes und leichtes Polyamid-Gehäuse
- » Turmalin und Ionengenerator
- » Kompatibel mit Diffusoren: 04346/50 - 01147 - 03036/50

- » Potenza: 2200W.
- » Motore compatto di lunga durata AC
- » Peso: 590 gr.
- » Portata d'aria: 83 m3/ora
- » 2 velocità, 3 temperature
- » Pulsante aria fredda
- » 2 bocchette regolabili: 1 largo, 1 stretto
- » Filtro rimovibile
- » Termostato di sicurezza
- » Cavo flessibile 3m
- » Voltaggio 220-240V~
- » Frequenza: 50/60 Hz
- » Design ergonomico
- » Corpo in poliammide robusto e leggero
- » Con tormalina e ionico
- » Compatibile con diffusori: 04346/50 - 01147 - 03036/50



TRAMUNTANA-Trockner Asciugacapelli TRAMUNTANA



Der Tramuntana-Trockner hat ein attraktives, ergonomisches und leichtes Design. Erhältlich in Schwarz und 4 sehr trendigen und angenehmen Farben. Enthält zwei Düsen unterschiedlicher Größe und einen Diffusor für lockiges Haar.

L'asciugacapelli Tramuntana ha un design accattivante, ergonomico e leggero. Disponibile in nero e 4 colori molto moderni. Include due bocchette di dimensioni diverse e un diffusore per capelli ricci.



REF. 04264/50

18,2 cm



INCLUS · INCLUDE



REF. 04264/62



REF. 04264/64



REF. 04264/68



REF. 04264/75

- » Leistung: 2000W
- » Kompakter AC-Motor mit langer Lebensdauer
- » Gewicht: 500 gr
- » Luftdurchsatz: 70 m3/Stunde
- » 2 Geschwindigkeiten, 3 Temperaturen
- » Kaltluft-Knopf
- » 2 Düsen: 1 breit, 1 schmal
- » Herausnehmbarer Filter
- » Sicherheitsthermostat
- » Kabel 3m mit Ring zum Aufhängen
- » Spannung 220-240V~
- » Frequenz: 50/60 Hz
- » Schalter seitlich
- » 1 Diffusor
- » Diffusorkompatibel: 04346/50

- » Potenza: 2000W.
- » Motore compatto di lunga durata AC
- » Peso: 500 gr.
- » Portata d'aria: 70 m3/ora
- » 2 velocità, 3 temperature
- » Pulsante aria fredda
- » 2 bocchette: 1 largo, 1 stretto
- » Filtro rimovibile
- » Termostato di sicurezza
- » Cavo flessibile 3m
- » Voltaggio 220-240V~
- » Frequenza: 50/60 Hz
- » Pulsanti laterali
- » Compatibile diffusore: 04346/50
- » 1 diffusore
- » Compatibile diffusore: 04346/50

Haartrockner MEDITERRÁNEO

Asciugacapelli MEDITERRÁNEO

MEDITERRÁNEO

1
u.m.vta6
box

Der Mediterranean Dryer hat ein attraktives, ergonomisches und leichtes Design. Erhältlich in Schwarz und 4 sehr trendigen und angenehmen Farben. Enthält zwei Düsen unterschiedlicher Größe und einen Diffusor für lockiges Haar.

L'asciugacapelli Mediterraneo ha un design accattivante, ergonomico e leggero. Disponibile in nero e 4 colori molto moderni. Include due bocchette di dimensioni diverse e un diffusore per capelli ricci.



REF. 04263/50

EINSCHLISSLICH · INCLUDE



18,2 cm



REF. 04263/62



REF. 04263/64



REF. 04263/68



REF. 04263/75

- » Leistung: 2000W
- » Kompakter AC-Motor mit langer Lebensdauer
- » Gewicht: 500 gr
- » Luftdurchsatz: 70 m3/Stunde
- » 2 Geschwindigkeiten, 3 Temperaturen
- » Kaltluft-Knopf
- » 2 Düsen: 1 breit, 1 schmal
- » Herausnehmbare Filter
- » Sicherheitsthermostat
- » Kabel mit Ring zum Aufhängen
- » Spannung 220-240V~
- » Frequenz: 50/60 Hz
- » 1 diffusor

- » Potenza: 2000W.
- » Motore compatto di lunga durata AC
- » Peso: 500 gr.
- » Portata d'aria: 70 m3/ora
- » 2 velocità, 3 temperature
- » Pulsante aria fredda
- » 2 bocchette: 1 largo, 1 stretto
- » Filtro rimovibile
- » Termostato di sicurezza
- » Cavo flessibile
- » Voltaggio 220-240V~
- » Frequenza: 50/60 Hz
- » 1 diffusore

Trockner IL FUTURO Asciugatrice IL FUTURO

1 u.m.vta
12 box

- » Leistung: 2150W
 - » Kompakter AC-Motor mit langer Lebensdauer
 - » Gewicht: 595 gr
 - » Luftdurchsatz: 70 m3/Stunde
 - » 2 Geschwindigkeiten, 3 Temperaturen
 - » Kaltluft-Knopf
 - » 2 Düsen
 - » Herausnehmbarer Filter
 - » Sicherheitsthermostat
 - » Kabel 3m mit Ring zum Aufhängen
 - » Spannung 220-240V~
 - » Frequenz: 50/60 Hz
 - » Neues System zur Emission negativer Ionen zur Beseitigung statischer Elektrizität aus dem Haar
 - » Traditioneller und seitlicher Griff
 - » Faltbar
 - » Mit Ionen
 - » Kompatibel mit Diffusoren: 04346/50 - 01147
- » Potenza: 2150W.
 - » Motore compatto di lunga durata AC
 - » Peso: 595 gr.
 - » Portata d'aria: 70 m3/ora
 - » 2 velocità, 3 temperature
 - » Pulsante aria fredda
 - » 2 bocchette
 - » Filtro rimovibile
 - » Termostato di sicurezza
 - » Cavo flessibile 3m
 - » Voltaggio 220-240V~
 - » Frequenza: 50/60 Hz
 - » Nuovo sistema di emissione di ioni negativi per eliminare l'elasticità statica del capello
 - » Impugnatura tradizionale e laterale
 - » Pieghevole
 - » Ionico
 - » Compatibile con diffusori: 04346/50 - 01147



REF.03051

22 cm

Trockner TURBO STRATOS 3800 ETI Asciugacapelli TURBO STRATOS 3800 ETI



1 u.m.vta
12 box

- » Leistung: 2400W
 - » Kompakter AC-Motor mit langer Lebensdauer
 - » Gewicht: 590 gr
 - » Luftdurchsatz: 99 m3/Stunde
 - » 2 Geschwindigkeiten, 3 Temperaturen
 - » Kaltluft-Knopf
 - » 2 Düsen: 1 breit, 1 schmal
 - » Herausnehmbarer Filter
 - » Sicherheitsthermostat
 - » Kabel mit Ring zum Aufhängen
 - » Schallpegel: 69 dB
 - » Spannung 220-240V~
 - » Frequenz: 50/60 Hz
 - » Kompatibel mit Diffusoren: 04346/50 - 01147 - 03036/50
- » Potenza: 2400W.
 - » Motore compatto di lunga durata AC
 - » Peso: 590 gr.
 - » Portata d'aria: 99 m3/ora
 - » 2 velocità, 3 temperature
 - » Pulsante aria fredda
 - » 2 bocchette: 1 largo, 1 stretto
 - » Filtro rimovibile
 - » Termostato di sicurezza
 - » Cavo flessibile
 - » Impatto sonoro: 69 dB
 - » Voltaggio 220-240V~
 - » Frequenza: 50/60 Hz
 - » Compatibile con diffusori: 04346/50 - 01147 - 03036/50



REF.02931

24 cm

NANO STRATOS 3700 ETI-Trockner Asciugacapelli NANO STRATOS 3700 ETI



1 u.m.vta
12 box

- » Leistung: 2200W
 - » Professioneller AC-Motor mit langer Lebensdauer
 - » Gewicht: 575 gr
 - » Luftdurchsatz: 100 m3/Stunde
 - » 2 Geschwindigkeiten, 3 Temperaturen
 - » Kaltluft-Knopf
 - » 2 Düsen
 - » Herausnehmbarer Filter
 - » Sicherheitsthermostat
 - » Kabel mit Ring zum Aufhängen
 - » Schallpegel: niedrig
 - » Spannung 220-240V~
 - » Frequenz: 50/60 Hz
 - » Ausgezeichnete Technologie
 - » Kompatibel mit Diffusoren: 04346/50 - 01147 - 03036/50
- » Potenza: 2200W.
 - » Motore professionale di lunga durata AC
 - » Peso: 575 gr.
 - » Portata d'aria: 100 m3/ora
 - » 2 velocità, 3 temperature
 - » Pulsante aria fredda
 - » 2 bocchette
 - » Filtro rimovibile
 - » Termostato di sicurezza
 - » Cavo flessibile
 - » Voltaggio 220-240V~
 - » Impatto sonoro: basso
 - » Frequenza: 50/60 Hz
 - » Tecnologia avanzata
 - » Compatibile con diffusori: 04346/50 - 01147 - 03036/50



REF. 03003/50

19,8 cm

Halter für Trockner Porta asciugacapelli



REF.04431

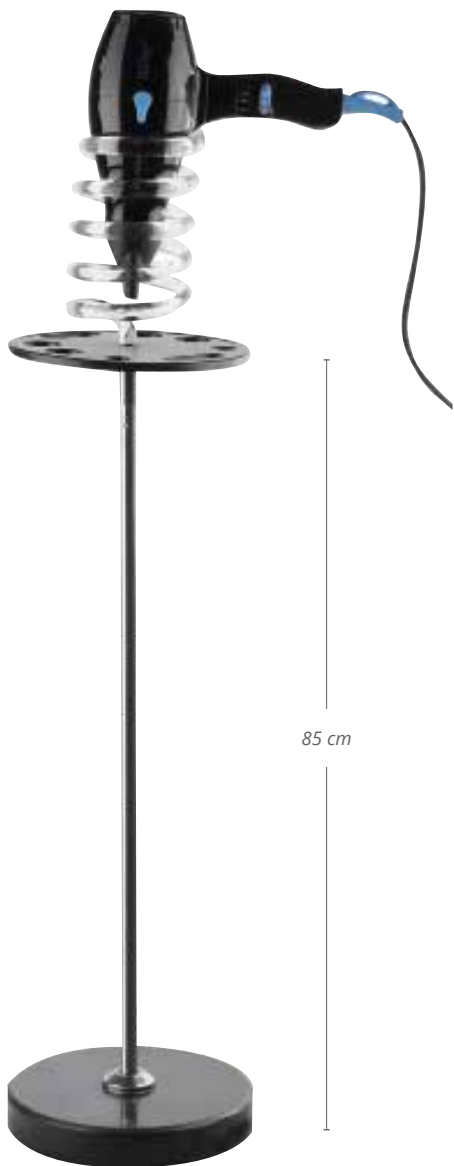

Ständer-Trocknerhalter aus Metall, geeignet für Trockner mit großer Düse. Leicht zu handhaben und zu bewegen, komfortabel für seine Stabilität. Elegantes und modernes Design.

Porta asciugacapelli con piedistallo in metallo, adatto per asciugacapelli con bocchette grandi. Facile da maneggiare e spostare, comodo per la sua stabilità. Design elegante e moderno.

Metall-wandhalter

Porta-asciugacapelli da parete in metallo



REF.07275

- » Material: aluminium
- » Mit gummeinfassung

- » Materiale: alluminio
- » Con finitura in gomma



Verstellbarer Halter für Trockner Porta asciugacapelli adattabile



REF. 00672



- » Metall
- » Metallo



REF. 02830



Universeller Diffusor

Diffusore universale



Diffusor schwarz
Diffusore nero



REF. 01147

Diffusor farbig
Diffusore colori misti



REF. 01147/99



Diffusor schwarz
Diffusore nero



REF. 03036/50

Diffusor farbig
Diffusore colori misti



REF. 03036/99

Faltbare SILICONE-Diffusoren

Diffusori pieghevoli in SILICONE

1
u.m.vta

8
box

- » Verteilt die Wärme gleichmäßig
- » Spezielles Design, leicht, faltbar und platzsparend
- » Universell, passt auf die meisten Trockner
- » Ref. 04346: Max. Höhe 12,9 cm min. 6,8 cm
- » Ref. 04346: Ø 6,3 cm - Ø 13,9 cm

- » Distribuisce il calore in modo uniforme
- » Design speciale, leggero, pieghevole e non occupa spazio
- » Universale, si adatta alla maggior parte degli asciugacapelli
- » Rif. 04346 Altezza massima 12,9 cm min. 6,8 cm
- » Rif. 04346 Ø 6,3 cm - Ø 13,9 cm



REF. 04346/62



REF. 04346/68



REF. 04346/64



REF. 04346/50



Schaum-Diffusor

Diffusore in spugna

1
u.m.vta

12
box

Ideal, um die Dochtwirkungsarbeit zu wärmen,
Färbung, Dauerwellen und Haarbehandlungen

*Ideale per fornire calore a meches, mettere colore,
permanenti e trattamenti per capelli*



REF. 02371

Schwarzer Aktivator

Attivatore nero

- » Leistung: 900W
- » Thermostimulator der neuesten Generation
- » Kompakt, braucht wenig Platz
- » Es wirkt mittels Wärme, so dass die Farbe in kurzer Zeit eindringt
- » Mit Zeitschaltuhr, elektronische Regelung der Energieabstrahlung
- » 5 einzelne Schalter zum Einschalten jeder der Lampen
- » Widerstandstyp: Infrarot
- » Maximale Temperatur 40°C
- » Frequenz: 50 Hz
- » Spannung 220-240V~

- » Potenza: 900W.
- » Stimolatore di calore di ultima generazione
- » Compatto, occupa poco spazio
- » Agisce per mezzo del calore in modo che il colore penetri velocemente
- » Con timer, regolatore elettronico della radiazione di energia
- » 5 singoli interruttori per accendere ciascuna delle lampade
- » Tipo di resistenza: infrarossi
- » Temperatura massima 40°C
- » Frequenza: 50 Hz
- » Voltaggio 220-240V~



Standfuß
Con piedistallo

REF.03007

Wandhalter
Supporto a parete

REF.03008

Weißer Aktivator

Attivatore bianco

- » Leistung: 1400W
- » Kompakter Thermostimulator der neuesten Generation
- » Es hat Belüftung
- » Mit Zeitschaltuhr, elektronischer Energiestrahlungsregler
- » Digitale Anzeige
- » Spannung: 220-240V~
- » Material: Nylon
- » Art der Resistenz: Infrarot
- » 3 Geschwindigkeiten

- » Potenza: 1400W.
- » Stimolatore di calore di ultima generazione compatto
- » Con ventilazione
- » Con timer, regolatore elettronico della radiazione di energia
- » Display digitale
- » Tensione: 220-240V~
- » Materiale: nylon
- » Tipo di resistenza: infrarossi
- » 3 velocità



Standfuß
Con piedistallo

REF.04273

Wandhalter
Supporto a parete

REF.04274

Elektronischer fernbetätigungsschalter schwarz

Termostimolatore elettronico nero

Kompakter Thermostimulator für Friseure, mit einem innovativen Design, das den höchsten Komfort für den Kunden bietet.

NEW

Eigenschaften:

- » Timer
- » Elektronischer Regler für die Energieabstrahlung
- » 5 einzelne Schalter zum Ein- und Ausschalten jeder kreisförmigen Lampe

Termostimolatore per parrucchieri compatto e dal design innovativo che offre il massimo confort per la cliente.

Caratteristiche:

- » Temporizzatore
- » Regolazione elettronica dell'irradiazione di energia
- » 5 interruttori singoli per l'accensione e spegnimento di ogni lampada circolar



Mit fuss
Con base da terra

REF.07433

Mit wandhalterung
Supporto a parete

REF.07434

Trockenhaube atomic turbo mit fuss

Casco ASCIUGACAPELLI ATOMIC turbo con base da terra



Professionelle Haartrockenhaube, mit Timer, Thermostat, Temperatur-Kontrollleuchte und Geschwindigkeitsregler.

- » Retro-futuristisches Design mit integrierter Blende
- » Höhere Leistung- 1400W ULTRA POWER
- » Glocke mit Luftstromausrichtung

Konfigurationen:

- » Automatisch / 1 Geschwindigkeit
- » 4 Geschwindigkeiten TURBO

Casco asciugacapelli professionale con temporizzatore, termostato, spia di controllo della temperatura e selettore di velocità.

- » Design retro-futuristico con visiera integrata
- » Potenza maggiorata - 1400W ULTRA POWER
- » Campana con direzionamento del flusso d'aria

Configurazioni:

- » Automatico/1 velocità
- » 4 velocità TURBO



Standfuß
Con piedistallo

REF.07436



Turbo-Hauben-Trockner GONG

Casco asciugacapelli Turbo GONG



- » Frequenz: 50 Hz
- » Leistung 1400W
- » TURBO-Geschwindigkeiten mit Zeitschaltuhr, Regelthermostat und Kontrollleuchte. Motor mit 4 Geschwindigkeiten ab 600 U/min
- » Geschwindigkeit 1: Leistung für freies und netzfreies Kämmen und Trocknen
- » Geschwindigkeit 2: Leistung für normales Kämmen und Trocknen
- » Geschwindigkeit 3: schnelle Trocknung
- » Geschwindigkeit 4: ultraschnelle Trocknung dank des hohen und gleichmäßigen Luftstroms

- » Frequenza: 50 Hz
- » Potenza 1400W.
- » Velocità TURBO con timer, termostato di regolazione e spia di controllo. Motore a 4 velocità da 600 giri al minuto
- » Velocità 1: servizi professionali di acconciatura e asciugatura libera senza retina
- » Velocità 2: servizi professionali di acconciatura e asciugatura normale
- » Velocità 3: asciugatura rapida
- » Velocità 4: asciugatura ultrarapida grazie all'elevata uniformità del portata d'aria



1 Geschwindigkeit
1 velocità

1 Geschwindigkeit
1 velocità

REF. 03005/50

REF. 03005/58

- » Modernes und ergonomisches design.
- » "Monofork"-system, das probleme beim brechen des scharnieres vermeidet
- » Trockner. Sehr schnelles trocknen durch den großen luftstrom verteilt
- » Gleichmässig
- » Einlassmessdurchmesser 28 cm
- » Inner max measure diameter 39 cm

- » Design moderno ed ergonomico.
- » Sistema "monoforzo" che previene problemi di rottura della cerniera anteriore
- » Essiccatore. Asciugatura molto veloce per il grande portata d'aria distribuita
- » Uniformemente
- » Diametro misurato aspirazione 28 cm
- » Misura massima interna diametro 39 cm

Haubentrockner GONG
Casco asciugacapelli GONG

- » Leistung 1400W
- » 1 Geschwindigkeit
- » Modernes und ergonomisches Design
- » Sehr schneller Trockner aufgrund des gleichmäßig verteilten hohen Luftstroms
- » Höhe 210 cm für die Wandmontage des Arms

- » Potenza 1400W.
- » 1 velocità
- » Design moderno ed ergonomico
- » Asciugacapelli molto veloce grazie al grande portata d'aria distribuito in modo uniforme
- » Altezza di 210 cm per montare il braccio alla parete



Wandhalter
Supporto a parete

REF. 03006

REF. 03006/58

Haubentrockner HOT WIND automatisch
Casco asciugacapelli HOT WIND automatico

- » Leistung: 1000W
- » Spannung: 220-240V~
- » Frequenz: 50/60Hz
- » 1 Geschwindigkeit
- » Motor mit 1300 U/min
- » Werkstoff: Stahl
- » Haubenmaterial: ABS

- » Potenza: 1000W
- » Voltaggio: 220-240V~
- » Frequenza: 50/60Hz
- » 1 velocità
- » Motore da 1300 rpm
- » Materiale: acciaio
- » Materiale del casco: ABS



Standfuß
Con piedistallo

REF. 04272/50

Ceriotti-Dampfhaube mit Standfuß
Vaporizzatore Ceriotti con piedistallo



Pink
Fucsia



REF.04275/68

Silber
Argento



REF.04275/54

- » Leistung: 1000W
- » Haube mit verstellbarem Visier Nylon, Polycarbonat und Stahl
- » Ohne OZONE

- » Potenza: 1000W.
- » Campana con visiera regolabile in nylon, policarbonato e acciaio
- » Senza OZON



Ceriotti-Dampfhaube GEYSER OZONO mit Standfuß
Vaporizzatore Ceriotti GEYSER OZONO con piedistallo

Professioneller Zerstäuber für Schönheits- und Heilbehandlungen. Erzeugt Dampf, Geyser begünstigt die Absorption der Haarpflegeprodukte durch die Kopfhaut und reduziert die Zeit der Exposition erheblich. Die Ozonlampe erzeugt (bei den angepassten Modellen) einen sterilisierenden Effekt, der dabei helfen kann, die Gesundheit des Haar und der Haut zu verbessern.

Vaporizzatore professionale per trattamenti estetico curativi. Generando vapore, Geyser aiuta la penetrazione dei prodotti tricologici nelle cuticole riducendo drasticamente i tempi di posa. La lampada ad ozono (nei modelli predisposti) produce un effetto sterilizzante che può aiutare a migliorare la salute del capello e della cute.

- » Timer
- » Elektronischer Regler für Temperatur und Dampfmenge
- » Betriebsanzeige
- » Kondensat-Behälter
- » Ozonlampe

- » Temporizzatore
- » Regolatore elettronico della temperatura e della quantità di vapore
- » Spia di funzionamento
- » Serbatoio condensa
- » Lampada ad ozono



REF.07435



Haubentrockner ORLA Casco asciugacapelli ORLA



- » Leistung: 1175W
- » Spannung: 220-240V~
- » Frequenz: 50/60Hz
- » 5 Geschwindigkeiten
- » Zeituhr maximal 60 Minuten
- » Temperatur maximal 70°C
- » Das Gerät verfügt über eine Sicherheitsvorrichtung, die im Falle einer Fehlfunktion automatisch aktiviert wird

- » Potenza: 1175W.
- » Voltaggio: 220-240V~
- » Frequenza: 50/60Hz
- » 5 velocità
- » Timer 60 minuti massimo
- » Temperatura massima 70°C
- » L'apparecchio dispone di un dispositivo di sicurezza che si attiva automaticamente in caso di malfunzionamento del dispositivo

Wandhalter
Supporto a parete

REF.03314



Innendurchmesser
Misura interna

33 cm

Standfuß
Con piedistallo

REF.03313



Eurostil-Dampfhaube Vaporizzatore Eurostil



- » Leistung: 400W
- » Vorwärmesystem
- » Einschaltanzeige-LED
- » LED-Licht und Ton, die Wassermangel im Verdampfer anzeigen
- » Ozon-Generator
- » Zeitschaltuhr
- » Innenbehälter für Wasserkondensation (Dampferzeugung)
- » mit Entlastungsventil und System zur Rückführung
- » NUR destilliertes Wasser kann verwendet werden

- » Potenza: 400W.
- » Sistema di preriscaldamento
- » Spia LED di alimentazione
- » Spia LED luminosa e acustica per indicare la mancanza d'acqua nel vaporizzatore
- » Generatore di ozono
- » Timer
- » Serbatoio interno per condensazione acqua (produzione vapore)
- » Con valvola di sfogo e sistema per eventuale ritorno
- » È possibile utilizzare SOLO acqua distillata

Standfuß
Con piedistallo

REF.03315



Wandhalter
Supporto a parete

REF.03316

Valera Haubentrockner
Casco asciugacapelli Valera



- » Leistung: 600W
- » 3m langes Kabel
- » Komfortabler und ergonomischer Haubentrockner
- » 2 Geschwindigkeiten und 3 Temperaturen
- » Kaltluft-Schalter
- » Ultraleicht, leise und weicher Oberfläche
- » Praktische Reisetasche inklusive
- » Ionen-Generator
- » Frequenz: 50/60 Hz

- » Potenza: 600W.
- » Cavo di 3m di lunghezza
- » Casco asciugacapelli comodo ed ergonomico
- » 2 velocità e 3 temperature
- » Pulsante aria fredda
- » Ultraleggero, silenzioso e morbido al tatto
- » Pratica borsa da viaggio inclusa
- » Generatore di ioni
- » Frequenz: 50/60 Hz

Haubentrockner mit Ionisator VALERA mod. Ionic Confort

Casco asciugacapelli con ionizzatore VALERA mod. Ionic Confort



REF. 04615

Heizwickler
Rulli caldi

REMINGTON



- » Leistung: 300W
- » 20 rollen, die in weichem velvet abgedeckt und mit wachs gefüllt sind eine weiche folie und anhaltende wärme
- » Ionen für erschrockenes haar
- » 3 grössen: 4 kleine (20 mm), 10 mittel (23 mm) und 6 grosse de 27 mm)
- » Power indicator pilot
- » Anzeigelicht, das die farbe ändert, wenn die rollen bereit sind verwenden rollen mit kalten enden für ein einfaches styling
- » 20 farbige gabeln und klemmklammer nach rollentyp

- » Potenza: 300W.
- » 20 rulli rivestiti in morbido velluto e riempiti di cera per ottenere un morbido scivolo e calore che dura
- » Ioni per capelli spaventati
- » 3 misure: 4 small (20 mm), 10 medium (23 mm) e 6 grandi (27 millimetri)
- » Pilota indicatore di potenza
- » Indicatore luminoso che cambia colore quando i rulli sono pronti uso rulli a freddo per un facile stile
- » 20 forche colorate e clip di fissaggio a seconda del tipo di rullo

REF. 06241



EASY-Platten Piastra EASY



Keramikplatten mit Turmalin, die das Haar pflegen und ihm Glanz und Geschmeidigkeit verleihen. Seine ionische Ladung verhindert, dass das Haar elektrisiert und kraus wird, und mit der Nano-Silber-Technologie werden Bakterien eliminiert. Automatische Abschaltautomatik: Das Gerät schaltet sich automatisch ab, wenn ca. 60 Minuten nicht benutzt wird.

Piastra in ceramica con tormalina che si prendono cura dei capelli donando lucentezza e morbidezza. La carica ionica impedisce ai capelli di diventare elettrici e crespi e la tecnologia Nano Silver elimina i batteri. Funzione autospegnimento automatico: l'apparecchio si spegne automaticamente se non viene utilizzato dopo circa 60 minuti.

- » Temperatur zwischen 130°C - 230°C
- » Leistung: 44W
- » Sicherheitsthermostat
- » Kabellänge: 2,7 m Kabel mit 360°-Drehung

- » Temperatura tra 130°C - 230°C
- » Potenza: 44W.
- » Termostato di sicurezza
- » Misura del cavo: 2,7 m con rotazione di 360°



REF. 06332/68

REF. 06332/70

INFRAROT Glätteisen Keramik und Turmalin Piastra a INFRAROSSI con ceramica e tormalina



Keramikplatten mit Turmalin, die das Haar pflegen und ihm Glanz und Geschmeidigkeit verleihen. Seine ionische Ladung verhindert, dass das Haar elektrisiert und kraus wird, und mit der Nano-Silber-Technologie werden Bakterien eliminiert. Automatische Abschaltautomatik: Das Gerät schaltet sich automatisch ab, wenn ca. 60 Minuten nicht benutzt wird. Infrarotlicht, das das Haar entgiftet und desinfiziert und gleichzeitig die harte Wärmeübertragung der Platten reduziert. Seine Haupteigenschaften sind die Verbesserung der Durchblutung und die Stimulierung des Haarwuchses.

Piastra in ceramica con tormalina che si prendono cura dei capelli donando lucentezza e morbidezza. La carica ionica impedisce ai capelli di diventare elettrici e crespi e la tecnologia Nano Silver elimina i batteri. Funzione autospegnimento automatico: l'apparecchio si spegne automaticamente se non viene utilizzato dopo circa 60 minuti. Luce infrarossa che disintossica e disinfetta i capelli e allo stesso tempo riduce l'aggressione del calore delle piastre. Le sue principali proprietà sono il miglioramento della circolazione e la stimolazione della crescita dei capelli.

- » Temperatur zwischen: 130°C - 230°C
- » Leistung: 44W
- » Sicherheitsthermostat
- » Kabellänge: 2,7 m Kabel mit 360°-Drehung
- » Plattenheizung: 20 Sekunden
- » MCH-Widerstand
- » LCD-Display mit Temperaturanzeige
- » Interner Thermostat verhindert Überhitzung
- » „SOFT-TOUCH“ Griff
- » Keramik und Turmalin

- » Temperatura tra: 130°C - 230°C
- » Potenza: 44W.
- » Termostato di sicurezza
- » Misura del cavo: Cavo da 2,7 m con rotazione di 360°
- » Riscaldamento della piastra: 20 secondi
- » Resistenza MCH
- » Display LCD che indica la temperatura
- » Termostato interno che impedisce il surriscaldamento
- » Manico "SOFT-TOUCH"
- » Ceramica e tormalina



REF. 06331/68

FRIZZE Profi-Glätteisen

Piastra professionale FRIZZE



Turmalinplatten, die das Haar pflegen und ihm Glanz und Geschmeidigkeit verleihen. Seine ionische Ladung verhindert, dass das Haar elektrisiert und kraus wird, und mit der Nano-Silber-Technologie werden Bakterien eliminiert.

Piastre con tormalina che si prendono cura dei capelli donando lucentezza e morbidezza. La carica ionica impedisce ai capelli di diventare elettrici e crespi e la tecnologia Nano Silver elimina i batteri.



REF. 06163/68



- » Temperatur: zwischen 130°C und 230°C
- » Leistung: 65W
- » Sicherheitsthermostat
- » Kabellänge: 3 m Kabel mit 360°-Drehung
- » Spannung: 110 - 240 V~
- » Frequenz: 50/60 Hz
- » Automatische Abschaltung nach 60 Minuten
- » Widerstand: ultraschnelle Erwärmung mit PTC-Widerstand
- » Temperatureinstellung per Skala
- » Mikroprozessor-Steuerung
- » Soft touch Oberfläche
- » Temperatur-Leuchtanzeiger
- » Keramik und Turmalin
- » 3 austauschbare Platten
- » Für natürliches Haar
- » NICHT FÜR SYNTHETISCHES ODER NASSES HAAR VERWENDEN

- » Temperatura tra 130°C - 230°C
- » Potenza: 65W.
- » Termostato di sicurezza
- » Misura del cavo: Cavo da 3 m con rotazione di 360°
- » Voltaggio: 110 - 240 V~
- » Frequenza: 50/60 Hz
- » Spegnimento automatico dopo 60 minuti di inutilizzo
- » Resistenza: riscaldamento ultra rapido con resistenza PTC
- » Regolatore della temperatura a manopola
- » Controllo con microprocessore
- » Finitura soft touch
- » Spia della temperatura
- » Ceramica e tormalina
- » 3 piastre intercambiabili
- » Per capelli naturali
- » NON USARE SU CAPELLI SINTETICI O BAGNATI

Professionelles Keramik- und Turmalin-Glätteisen

Piastra professionale con CERAMICA e TORMALINA



Keramikplatten mit Turmalin, die das Haar pflegen und ihm Glanz und Geschmeidigkeit verleihen. Seine ionische Ladung verhindert, dass das Haar elektrisiert und kraus wird, und mit der Nano-Silber-Technologie werden Bakterien eliminiert.

Piastra in ceramica con tormalina che si prendono cura dei capelli donando lucentezza e morbidezza. La carica ionica impedisce ai capelli di diventare elettrici e crespi e la tecnologia Nano Silver elimina i batteri.



REF. 06173/50



REF. 06173/53



REF. 06173/70



- » Temperatur: zwischen 80°C und 230°C
- » Leistung: 43W
- » Interner Thermostat verhindert Überhitzung
- » Kabellänge: 3 m Kabel mit 360°-Drehung
- » Spannung: 110 - 240 V~
- » Frequenz: 50/60 Hz
- » LCD-Display zur Anzeige der Temperatur
- » Automatische Abschaltung nach 60 Minuten
- » Widerstand: Erwärmung der Platten in nur 20 Sekunden, mit MCH-Widerstand
- » Temperatureinstellung mit Hilfe von Tasten
- » Soft-Touch-Griff
- » Temperatur-Speicher
- » Für natürliches Haar
- » NICHT FÜR SYNTHETISCHES ODER NASSES HAAR VERWENDEN

- » Temperatura tra 80°C - 230°C
- » Potenza: 43W.
- » Termostato interno che impedisce il surriscaldamento
- » Misura del cavo: Cavo da 3 m con rotazione di 360°
- » Voltaggio: 110 - 240 V~
- » Frequenza: 50/60 Hz
- » Display LCD che indica la temperatura
- » Spegnimento automatico dopo 60 minuti di inutilizzo
- » Resistenza: riscaldamento della piastra in soli 20 secondi, con resistenza MCH
- » Regolatore della temperatura a pulsante
- » Manico "SOFT-TOUCH"
- » Memoria della temperatura
- » Per capelli naturali
- » NON USARE SU CAPELLI SINTETICI O BAGNATI

Profi-Eisen TITANIUM**Piastra professionale TITANIO**

Titanplatten, die das Haar pflegen und ihm Glanz und Geschmeidigkeit verleihen, und mit der Nano-Silber-Technologie, die Bakterien eliminiert.

Piastra in Titanio che si prendono cura dei capelli donando loro lucentezza e morbidezza e con tecnologia Nano Silver che elimina i batteri.



REF. 06174/50

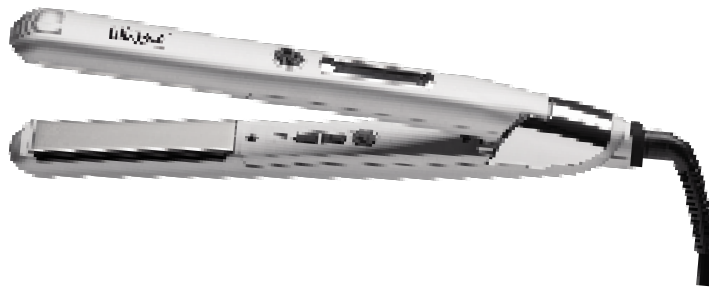

REF. 06174/54



REF. 06174/70



- » Temperatur: zwischen 80°C und 230°C
- » Leistung: 38W
- » Interner Thermostat verhindert Überhitzung
- » Kabellänge: 3 m Kabel mit 360°-Drehung
- » Spannung: 110 - 240 V~
- » Frequenz: 50/60 Hz
- » LCD-Display zur Anzeige der Temperatur
- » Automatische Abschaltung nach 60 Minuten
- » Widerstand: Erwärmung der Platten in nur 20 Sekunden, mit MCH-Widerstand
- » Temperatureinstellung mit Hilfe von Tasten
- » Soft-Touch-Griff
- » Temperatur-Speicher
- » Keramik und Turmalin
- » Für natürliches Haar
- » NICHT FÜR SYNTHETISCHES ODER NASSES HAAR VERWENDEN

- » Temperatura tra 80°C - 230°C
- » Potenza: 38W.
- » Termostato interno che impedisce il surriscaldamento
- » Misura del cavo: Cavo da 3 m con rotazione di 360°
- » Voltaggio: 110 - 240 V~
- » Frequenza: 50/60 Hz
- » Display LCD che indica la temperatura
- » Spegnimento automatico dopo 60 minuti di inutilizzo
- » Resistenza: riscaldamento della piastra in soli 20 secondi, con resistenza MCH
- » Regolatore della temperatura a pulsante
- » Manico "SOFT-TOUCH"
- » Memoria della temperatura
- » Ceramica e tormalina
- » Per capelli naturali
- » NON USARE SU CAPELLI SINTETICI O BAGNATI

ADVANCE Profi-Eisen

Piastra professionale ADVANCE



Keramikplatten, die das Haar pflegen und ihm Glanz und Geschmeidigkeit verleihen, sowie die Nano-Silber-Technologie, die Bakterien eliminiert.

Piastra in ceramica che si prendono cura dei capelli donando loro lucentezza e morbidezza e con tecnologia Nano Silver che elimina i batteri.



REF. 06139/50

REF. 06139/70

REF. 06139/71



- » Temperatur: zwischen 130°C und 230°C
- » Leistung: 50W
- » Interner Thermostat verhindert Überhitzung
- » Kabellänge: 2,7 m Kabel mit 360°-Drehung
- » Spannung: 110 - 240 V~
- » Frequenz: 50/60 Hz
- » LCD-Display zur Anzeige der Temperatur
- » Automatische Abschaltung nach 60 Minuten
- » Widerstand: Erwärmung der Platten in nur 20 Sekunden, mit MCH-Widerstand
- » Temperatureinstellung mit Hilfe von Tasten
- » Soft-Touch-Griff
- » Für natürliches Haar
- » NICHT FÜR SYNTHETISCHES ODER NASSES HAAR VERWENDEN

- » Temperatura tra 130°C - 230°C
- » Potenza: 50W.
- » Termostato interno che impedisce il surriscaldamento
- » Misura del cavo: Cavo da 2,7 m con rotazione di 360°
- » Voltaggio: 110 - 240 V~
- » Frequenza: 50/60 Hz
- » Display LCD che indica la temperatura
- » Spegnimento automatico dopo 60 minuti di inutilizzo
- » Resistenza: riscaldamento della piastra in soli 20 secondi, con resistenza MCH
- » Regolatore della temperatura a pulsante
- » Manico "SOFT-TOUCH"
- » Per capelli naturali
- » NON USARE SU CAPELLI SINTETICI O BAGNATI

Professionelles IONIC-Eisen

Piastra professionale IONIC



Keramikplatten, die das Haar pflegen und ihm Glanz und Geschmeidigkeit verleihen, sowie die Nano-Silber-Technologie, die Bakterien eliminiert.

Piastrre in ceramica che si prendono cura dei capelli donando loro lucentezza e morbidezza e con tecnologia Nano Silver che elimina i batteri.



REF. 06138/50

REF. 06138/59

REF. 06138/53



- » Temperatur: zwischen 130°C und 230°C
- » Leistung: 44W
- » Interner Thermostat verhindert Überhitzung
- » Kabellänge : 2,7 m Kabel mit 360°-Drehung
- » Spannung: 110 - 240 V~
- » Frequenz: 50/60 Hz
- » LED-Display zur Anzeige der Temperatur
- » Automatische Abschaltung nach 60 Minuten
- » Widerstand: Erwärmung der Platten in nur 20 Sekunden, mit MCH-Widerstand
- » Temperatureinstellung mit Hilfe von Tasten
- » Soft-Touch-Griff
- » Ionengenerator, der das Haar weich macht und befeuchtet und so die Trockenzeit verkürzt.
- » Plattenverriegelungssystem über Hebel
- » Keramik und Turmalin
- » Für natürliches Haar
- » NICHT FÜR SYNTHETISCHES ODER NASSES HAAR VERWENDEN

- » Temperatura tra 130°C - 230°C
- » Potenza: 44W.
- » Termostato interno che impedisce il surriscaldamento
- » Misura del cavo: Cavo da 2,7 m con rotazione di 360°
- » Voltaggio: 110 - 240 V~
- » Frequenza: 50/60 Hz
- » Display LCD che indica la temperatura
- » Spegnimento automatico dopo 60 minuti di inutilizzo
- » Resistenza: riscaldamento della piastra in soli 20 secondi, con resistenza MCH
- » Regolatore della temperatura a pulsante
- » Manico "SOFT-TOUCH"
- » Generatore di ioni, che ammorbidisce e idrata i capelli, riducendo i tempi di asciugatura.
- » Sistema di chiusura delle piastre tramite leva
- » Ceramica e tormalina
- » Per capelli naturali
- » NON USARE SU CAPELLI SINTETICI O BAGNATI

PLATINIUM-Keramik-Glätteisen Piastra ceramica PLATINIUM



PLATINIUM-Platten mit kippbaren Keramik- und Turmalinplatten
Piastra PLATINIUM con piastre basculanti in ceramica e tormalina

REF. 06145

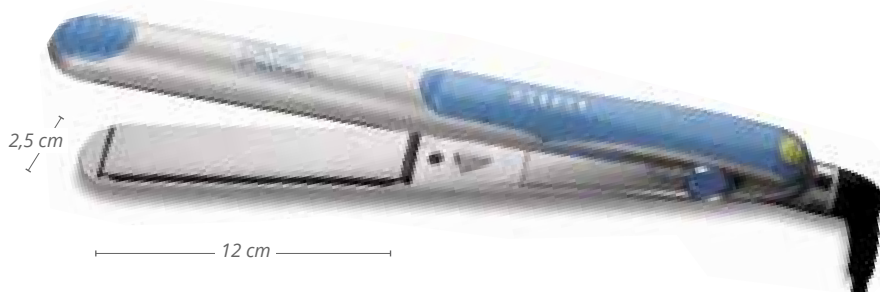

- » Temperatur: zwischen 150°C und 230°C
- » Leistung: 48W
- » Kabellänge: 2,7 m Kabel mit 360°-Drehung
- » Spannung: 220 - 240 V~
- » Frequenz: 50/60 Hz
- » Automatische Abschaltung nach 60 Minuten
- » Widerstand: Erwärmung der Platten in nur 20 Sekunden, mit MCH-Widerstand
- » Temperatureinstellung per Skala
- » Plattenverriegelungssystem über Hebel
- » Ionen-Generator
- » NICHT FÜR SYNTHETISCHES ODER NASSES HAAR VERWENDEN

- » Temperatura tra 150°C - 230°C
- » Potenza: 48W.
- » Misura del cavo: Cavo da 2,7 m con rotazione di 360°
- » Voltaggio: 220 - 240 V~
- » Frequenza: 50/60 Hz
- » Spegnimento automatico dopo 60 minuti di inutilizzo
- » Resistenza: riscaldamento della piastra in soli 20 secondi, con resistenza MCH
- » Regolatore della temperatura a manopola
- » Sistema di chiusura delle piastre tramite leva
- » Generatore di ioni
- » NON USARE SU CAPELLI SINTETICI O BAGNATI



Mini-Keramik-Haarglätter Zange
Mini piastra con placche in ceramica

Keramikplatten mit Turmalin, die das Haar pflegen und ihm Glanz und Geschmeidigkeit verleihen
Piastrre in ceramica con tormalina che si prendono cura dei capelli donando lucentezza e morbidezza

REF. 06568/50



- » Maximale Temperatur 200°C
- » Leistung: 22W
- » Sicherheitsthermostat
- » 2 m langes Gummikabel
- » Spannung: 100-240V~
- » Frequenz: 50/60 Hz
- » Aufheizen der Platten in nur 30 Sekunden, mit PTC-Widerstand
- » PTC-Widerstand verhindert Überhitzung
- » Geeignet für alle natürlichen Haartypen
- » NICHT FÜR SYNTHETISCHES ODER NASSES HAAR VERWENDEN

REF. 06568/68



- » Temperatura massima 200°C
- » Potenza: 22W
- » Termostato di sicurezza
- » Cavo in gomma lungo 2m
- » Voltaggio: 100-240V~
- » Frequenza: 50/60 Hz
- » Riscaldamento della piastra in soli 30 secondi, con resistenza PTC
- » Resistenza PTC che impedisce il surriscaldamento
- » Adatta a qualsiasi tipo di capello naturale
- » NON USARE SU CAPELLI SINTETICI O BAGNATI

REF. 06568/70

**Accessoires**
Accessori

REF. 02991

- » Halter für Glätteisen schmal Typ (06139) Mit Saugnäpfen

- » Supporto per piastra stretta modello 02926
- » Con ventose



REF. 03076

- » Fingerschutz für hohe Temperaturen

- » Protezione per le dita alte temperature



REF. 03857

- » Handschuh 3-Finger-Hochtemperaturschutz

- » Guanto protettivo a 3 dita per alte temperature



Glätteisenbürste
Spazzola lisciante

REF. 04583



- » Temperatur zwischen: 80°C und 230°C
- » Leistung: 55W
- » Interner Thermostat verhindert Überhitzung Aufheizen in 60 Sekunden
- » 2,5 m langes, um 360° drehbares Kabel
- » Spannung 220-240V~
- » LCD-Bildschirm
- » Automatische Abschaltung in 60 Minuten, wenn nicht verwendet
- » Für natürliches Haar
- » NICHT FÜR SYNTHETISCHES ODER NASSES HAAR VERWENDEN

- » Temperatura tra: 80°C - 230°C
- » Potenza: 55W.
- » Termostato interno che impedisce il surriscaldamento.
- » Cavo giratorio 360°, 2,5 m di lunghezza
- » Voltaggio 220-240V~
- » Display LCD
- » Spegnimento automatico in 60 min. se non utilizzato
- » Per capelli naturali
- » NON USARE SU CAPELLI SINTETICI O BAGNATI



Dampf-Glätteisenbürste

Spazzola piastra a vapore



Neues Dampfglätteisen mit Eurostil-Bürste der letzten Generation und Ausführung. Es ermöglicht Ihnen, Ihr Haar zu glätten, ohne es zu beschädigen, da der Wasserdampf das Haar während des Glättens vor dem Austrocknen schützt. Ihr Haar erhält ein glattes, glänzendes und gesundes Aussehen und Finish. Professionelle Nutzung.

Nuova piastra a vapore con spazzola Eurostil di ultima generazione e design. Ti permette di lisciare i capelli senza danneggiarli grazie al suo vapore acqueo che protegge i capelli dalla disidratazione durante la lisciatura. I capelli avranno un aspetto e una finitura liscia, lucente e sana. Uso professionale.



REF. 04737/50

REF. 04737/58

REF. 04737/68

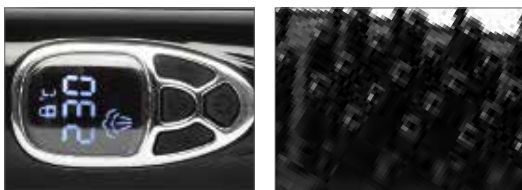

- » Temperatur: einstellbar zwischen 150°C und 230°C
- » Leistung: 75W
- » Interner Thermostat verhindert Überhitzung
- » Kabellänge: 2,5 m Kabel mit 360°-Drehung
- » Spannung 220-240V~
- » Frequenz: 50/60 Hz
- » LCD-Display mit Temperaturanzeige
- » Automatische Abschaltung nach 60 Minuten
- » Widerstand: Aufheizen in nur 90 Sekunden, mit PTC-Widerstand
- » Temperatureinstellung per Skala
- » Wasserdampf-Funktion
- » Geeignet für alle natürlichen Haartypen.
- » NICHT BEI KUNSTHAAR ANWENDEN



- » Temperatura: regolabile tra 150°C - 230°C
- » Potenza: 75W
- » Termostato interno che impedisce il surriscaldamento
- » Misura del cavo: Cavo da 2,5 m con rotazione di 360°
- » Voltaggio 220-240V~
- » Frequenza: 50/60 Hz
- » Display LCD che indica la temperatura
- » Spegnimento automatico dopo 60 minuti
- » Resistenza: riscaldamento della piastra in soli 90 secondi, con resistenza PTC
- » Regolatore della temperatura a manopola
- » Funzione vapore
- » Adatta a qualsiasi tipo di capello naturale
- » NON USARE SU CAPELLI SINTETICI

Mit Zwei-Wege-Rotation Con rotazione bidirezionale



Leistung: 45W
Potenza: 45W

REF. 04637

Ø 13-25



13 cm



Leistung: 70W
Potenza: 70W

REF. 04639

Ø 32



13,5 cm

- » Temperatur einstellbar zwischen: 130°C und 220°C
- » Interner Thermostat verhindert Überhitzung
- » 360° drehbares Gummikabel und 2,5 m lang
- » LCD-Bildschirm
- » Automatische Sicherheitsabschaltfunktion
- » Rohrbeschichtung aus Keramik und Turmalin
- » Drehknöpfe der Pinzette (rechts oder links)
- » Perlweißer Griff
- » Geeignet für jedes natürliche Haar
- » NICHT FÜR SYNTHETISCHES ODER NASSES HAAR GEEIGNET

- » Temperatura: regolabile tra 100°C - 220°C
- » Termostato interno che impedisce il surriscaldamento
- » Cavo in gomma girevole a 360° e lungo 2,5 m
- » Display LCD
- » Funzione di spegnimento automatico di sicurezza
- » Rivestimento dei tubi in ceramica e tormalina
- » Pulsanti rotazione arricciatura a destra o a sinistra
- » Manico bianco perla
- » Adatta a qualsiasi tipo di capello naturale
- » NON ADATTO PER CAPELLI SINTETICI O BAGNATI



Dreifach-Stab
Tripla barra

REF. 04594



Ø 22



- » Temperatur einstellbar zwischen 130°C und 220°C
- » Leistung 65W
- » Gummikabel drehbar um 360° und ist 2,5 m lang
- » Universelle Selbststeuerungs-Spannung 100-240V~
- » LCD-Bildschirm
- » Automatische Abschaltfunktion nach 60 Minuten ohne Aktivität
- » Keramik- und Turmalinbeschichtung der Röhren, die das Haar pflegen und ihm Glanz und Weichheit verleihen
- » Schnelles und sicheres Heizsystem
- » Soft-Touch-Griff
- » Für natürliches Haar
- » NICHT FÜR SYNTHETISCHES ODER NASSES HAAR GEEIGNET

- » Temperatura: regolabile tra 130°C - 220°C
- » Potenza 65W
- » minuti senza attività
- » Cavo in gomma girevole a 360° e lungo 2,5 m
- » Autocontrollo universale del voltaggio 100-240 V~
- » Display LCD
- » Spegnimento automatico dopo 60 minuti di inutilizzo
- » Rivestimento tubolare in ceramica e tormalina che si prende cura dei capelli donando lucentezza e morbidezza
- » Sistema di riscaldamento veloce e sicuro
- » Manico "SOFT-TOUCH"
- » Per capelli naturali
- » NON ADATTO PER CAPELLI SINTETICI O BAGNATI

Konisch
ConicoØ 13-25
REF. 04593Ø 19-32
REF. 04598

- » Leistung: 65W
- » Temperatur einstellbar zwischen 130°C und 220°C
- » Gummikabel drehbar um 360° und ist 2,5 m lang
- » Universelle Spannungssteuerung 100-240V~
- » LCD-Bildschirm
- » Automatische Abschaltfunktion nach 60 Minuten ohne Aktivität
- » Keramik- und Turmalinbeschichtung der Röhren, die das Haar pflegen und ihm Glanz und Weichheit verleihen
- » Schnelles und sicheres Heizsystem
- » Soft-Touch-Griff
- » Für natürliches Haar
- » NICHT FÜR SYNTHETISCHES ODER NASSES HAAR GEEIGNET

- » Potenza: 65W
- » Temperatura: regolabile tra 130°C - 220°C
- » Cavo in gomma girevole a 360° e lungo 2,5 m
- » Autocontrollo universale del voltaggio 100-240 V~
- » Display LCD
- » Spegnimento automatico dopo 60 minuti di inutilizzo
- » Rivestimento tubolare in ceramica e tormalina che si prende cura dei capelli donando lucentezza e morbidezza
- » Sistema di riscaldamento veloce e sicuro
- » Manico "SOFT-TOUCH"
- » Per capelli naturali
- » NON ADATTO PER CAPELLI SINTETICI O BAGNATI



Lockenstab mit Klemme Piastra per arricciacapelli

- » Temperatur einstellbar zwischen 185°C und 195°C
- » Leistung 25W
- » Gummikabel drehbar um 360° und ist 2,5 m lang
- » Spannung 230V~
- » Frequenz: 50 Hz
- » Mit Klemme

- » Temperatura: regolabile tra 185°C - 195°C
- » Potenza 25W.
- » Cavo in gomma girevole a 360° e lungo 2,5 m
- » Voltaggio 230V~
- » Frequenza: 50 Hz
- » Con pinza



REF. 01664



REF. 01981

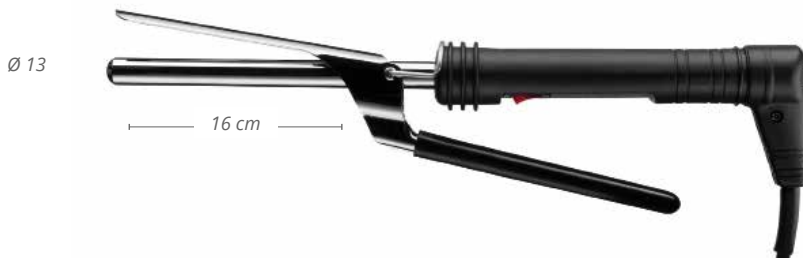

REF. 01665

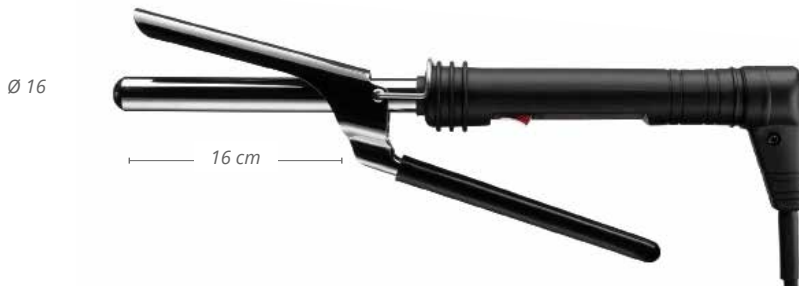

REF. 01666

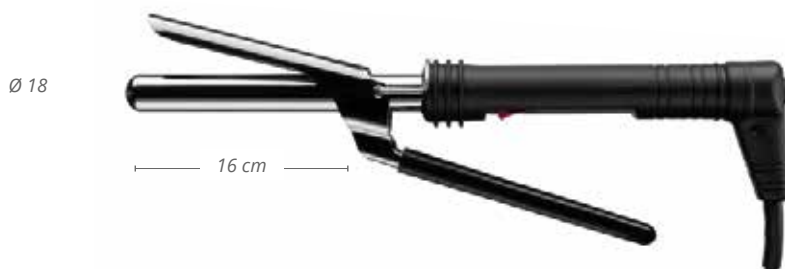

REF. 01667

Lockenstab mit Klemme
Piastra per arricciacapelli

- » Temperatur einstellbar zwischen 185°C und 195°C
- » Leistung: 25W
- » Gummikabel drehbar um 360° und ist 2,5 m lang
- » Spannung 230V~
- » Frequenz: 50 Hz
- » Mit Klemme

- » Temperatura: regolabile tra 185°C - 195°C
- » Potenza: 25W
- » Cavo in gomma girevole a 360° e lungo 2,5 m
- » Voltaggio 230V~
- » Frequenza: 50 Hz
- » Con pinza

Ø 22



REF. 01982

Ø 25



REF. 01668

Ø 32



REF. 02797

Unsere klassische Serie an Lockenstäben
La nostra linea più classica di arricciacapelli

Turmalin-Keramik Lockenstab

Arricciacapelli in ceramica e tormalina



- » Temperatur von 80°C bis 210°
- » Leistung: 65W
- » Thermostat zur Vermeidung von Überhitzung
- » 2,5 m langes 360°-Schwenkkabel
- » LCD-Bildschirm
- » Automatische Abschaltung nach 60 Minuten ohne Aktivität
- » Keramik- und Turmalinbeschichtung
- » Schnelles und sicheres Heizsystem
- » Hält die Temperatur konstant
- » Für natürliches Haar
- » Soft-Touch-Griff

- » Temperatura da 80°C a 210°
- » Potenza: 65W
- » Termostato per evitare il surriscaldamento
- » Cavo giratorio 360°, 2,5 m di lunghezza
- » Display LCD
- » spegnimento automatico dopo 60 minuti di inutilizzo
- » Rivestimento in ceramica e tormalina
- » Sistema di riscaldamento veloce e sicuro
- » Mantiene la temperatura costante
- » Per capelli naturali
- » Manico "SOFT-TOUCH"



REF. 04847

Ø 19



15,6 cm

REF. 04848

Ø 22



15,6 cm

REF. 04849

Ø 25



15,6 cm

REF. 04850

Ø 28



15,6 cm

REF. 04851

Ø 32



15,6 cm

REF. 04852

Ø 38



15,6 cm

Zweifach Lockenstab
*Arricciacapelli a doppio tubo*1
u.m.vta 12
box

REF. 03413

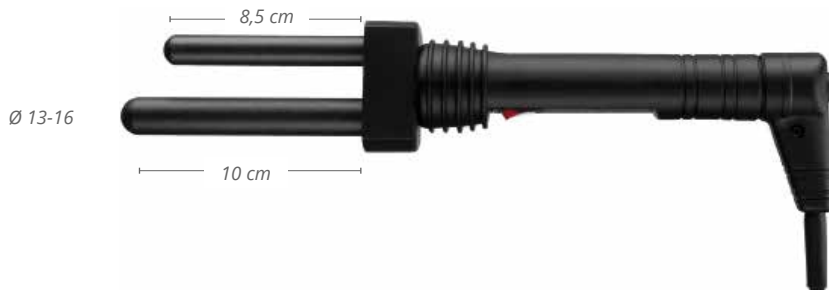

- » Temperatur von 185°C bis 195°C
- » Leistung: 25W
- » 2,5 m langes 360°-Schwenkkabel
- » Spannung 230-240V~
- » Frequenz: 50 Hz
- » Ideal, um wellige Locken zu erzeugen
- » Schnelles und sicheres Heizsystem
- » Hält die Temperatur konstant
- » Glattere, definiertere Locken

- » Temperatura da 185°C a 195°C
- » Potenza: 25W
- » Cavo giratorio 360°, 2,5 m di lunghezza
- » Voltaggio 230-240V~
- » Frequenza: 50 Hz
- » Ideale per fare onde finger waves
- » Sistema di riscaldamento veloce e sicuro
- » Mantiene la temperatura costante
- » Ricci con finitura più liscia e definita

Konischer Lockenstab
*Arricciacapelli conico*1
u.m.vta 1
box

REF. 03414

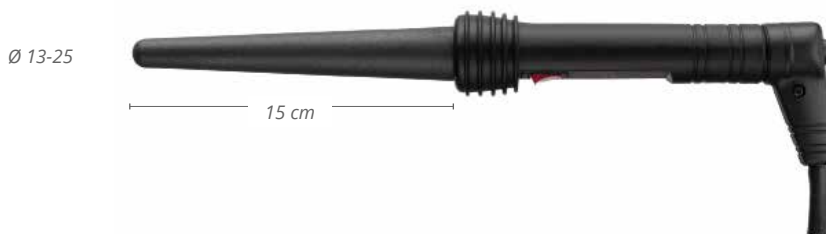

- » Temperatur von 185°C bis 195°C
- » Leistung: 25W
- » Aluminiumrohr mit Teflonbehandlung
- » Schnelles und sicheres Heizsystem
- » Hält die Temperatur konstant

- » Temperatura da 185°C a 195°C
- » Potenza: 25W
- » Tubo in alluminio con trattamento in Teflon
- » Sistema di riscaldamento veloce e sicuro
- » Mantiene la temperatura costante

Elektrische Wärmebürste
*Spazzola elettrica termica*1
u.m.vta 1
box

REF. 01949



- » Temperatur von 185°C bis 195°C
- » Leistung: 25W
- » 2,5 m langes 360°-Schwenkkabel
- » Spannung 230V~
- » Frequenz: 50 Hz
- » Ideal für weiche Locken

- » Temperatura da 185°C a 195°C
- » Potenza: 25W
- » Cavo giratorio 360°, 2,5 m di lunghezza
- » Voltaggio 230V~
- » Frequenza: 50 Hz
- » Ideal para cachos macios

Schweißzange für Extensions Saldatore per extension

Leistung: 21W
Potenza: 21W



REF. 02557



Leistung: 26W
Potenza: 26W



REF. 02558



Nachfüllbarer Farbmischer Miscelatore colorante ricaricabile



REF. 04092



Ideal zum schnellen und automatischen Mischen von Farbstoffen
Ideale per miscelare i coloranti in modo rapido e automatico



- » Leistung: 9W
- » Spannung: 100-240V~
- » Wiederaufladbarer Mischer (Gesamtladezeit 180 Minuten und funktioniert dann 80 Minuten)
- » Funktioniert im Leerlauf 100 Minuten
- » 4 Schalen mit 400 ml mit rutschfestem Gummi und 4 Haarfärbepinsel
- » Hält an, wenn Sie den Deckel öffnen
- » Zeitauswahl 45-60 und 75 s
- » Mit manueller Ein-/Ausschalttaste, die Funktion kann angehalten werden oder wird automatisch nach 3min gestoppt.
- » Die Mischgitter sind aus rostfreiem Stahl mit einer Kunststoffbeschichtung
- » Ersatz-Deckel Mischer RE04092/01
- » Ersatz-Mischgitter RE04092/02
- » Abmessungen 156 x 126 x 139 mm

- » Potenza: 9W
- » Voltaggio: 100-240V~
- » Miscelatore ricaricabile (carica totale 180 minuti e 80 min di funzionamento)
- » A vuoto funziona 100 minuti
- » 4 ciotole con gomma antiscivolo da 400 ml e 4 pennelli
- » Si ferma se il coperchio viene aperto
- » Selezione del tempo 45-60 e 75 s
- » Con il pulsante on/off manuale, se viene acceso funziona circa 3 minuti e si ferma se viene spento per qualsiasi motivo.
- » Le eliche sono in acciaio inossidabile rivestite in plastica
- » Ricambio coperchio miscelatore RE04092/01
- » Ricambio elica miscelatore RE04092/02
- » Dimensioni 156 x 126 x 139 mm



UV-Sterilisator Eurostil-Kunststoff
Sterilizzatore UV Eurostil in plastica

REF. 06618

- » Leistung: 8W
- » Ultraviolett-Sterilisator für alle Arten von Werkzeugen sowohl für die Friseur- als auch für die Schönheitspflege

- » Potenza: 8W
- » Sterilizzatore ultravioletto per tutti i tipi di strumenti, sia per parrucchieri che per estetisti

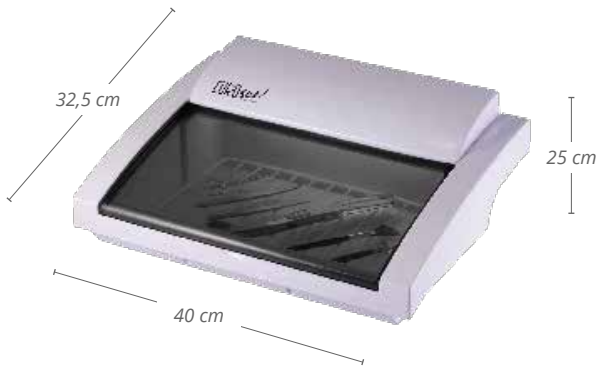
**Ersatzteile · Ricambi**Ersatz-UV-Lampe
Ricambio lampadina UV

REF. RE06618/01

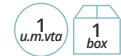
**Sterilisator Eurostil UV-Aluminium**
Sterilizzatore Eurostil UV in alluminio

REF. 03317

- » Leistung: 8W
- » Geeignet für die Sterilisation von kleinen Utensilien aus Kunststoff oder Metall unter Verwendung einer keimtötenden UVC-Lampe
- » Nicht für andere, nicht angegebene Objekte verwenden
- » Die Glühbirne hält etwa 1300/1500 Stunden (= 1 Jahr Betriebsdauer)

- » Potenza: 8W
- » Indicato per la sterilizzazione di piccoli utensili in plastica o metallo mediante una lampadina UVC germicida.
- » Non utilizzare con altri oggetti non indicati.
- » La lampadina dura circa 1300/1500 ore (= 1 anno di funzionamento).

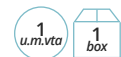
**Keimtötender Sterilisator gx4**
Sterilizzatore germicida gx4

REF. 03009/59

- » Leistung: 15W
- » Temperatur von 20°C bis 200°C
- » Ultraflach. Hochwertiges keimtötendes Licht

- » Potenza: 15W.
- » Temperatura da 20°C a 200°C
- » Ultra piatto. Luce germicida di alta qualità

Ersatz-UV-Lampe
Ricambio lampadina UV

REF. RE00891/01



Sanity Security Heissluft-Sterilisator

Sterilizzatore a calore secco Sanity Security

1 u.m.vta 1 box

REF. 03011

- » Temperatur von 20°C bis 200°C
- » Leistung 400W
- » Innenmaße: 25 cm x 14,5 cm x 7 cm

- » Temperatura da 20°C a 200°C
- » Potenza 400W.
- » Misure interne: 25 cm x 14,5 cm x 7 cm



EUROSTIL-Quarz-Sterilisator

Sterilizzatore al quarzo EUROSTIL

1 u.m.vta 6 box

REF. 07013

- » Quarz
- » Ideal für Metallutensilien wie Käämme, Scheren
- » Inklusive Tasche mit Quarzperlen

- » Quarzo
- » Ideale per utensili in metallo come pettini e forbici, etc.
- » Include borsa con perle di quarzo



Medisana Elektrischer Läusekamm

Pettine elettrico per pidocchi Medisana

1 u.m.vta 4 box

REF. 06584

- » Entfernt Läuse und Nissen bei einfachem Abbürsten.
- » Läuse werden durch elektrischen Strom bei Kontakt mit den Zinken des Kamms zerstört
- » Keine Nebenwirkungen, da keine Chemikalien benötigt werden
- » Batterien enthalten: 1 × 1,5v aa
- » Gewicht: 95 gr ca.

- » Elimina pidocchi e lendini con una semplice spazzolatura
- » I pidocchi vengono distrutti da una corrente elettrica a contatto con i denti del pettine
- » Nessun effetto collaterale perché non sono necessari prodotti chimici
- » Batterie incluse: 1 × 1,5v AA
- » Peso: 95 gr. aprox.



Haarabsauger Aspiratore per capelli



Der Absauger HAIR VACUUM mit moderner Technologie erleichtert die Arbeit für den Fachmann. Er verfügt über zwei Arbeitseinstellungen:
1) Handbetrieb: Für eine Absaugdauer von 5 sek. Bei Bedarf kann man es mit Knopfdruck mehrmals aktivieren.
2) Autobetrieb: Mit Hilfe der leistungsfähigen Sensoren können die Resthaare dauernd abgesaugt werden, das erleichtert dem Fachmann die Arbeit. Das Gerät schaltet aus, wenn keine Reste mehr vorhanden sind.

Aspiratore per capelli di ultima tecnologia. In modalità manuale, spazza i capelli verso la bocchetta di aspirazione alla base dell'apparecchio. Premere il pulsante di attivazione manuale e lasciare che HAIR VACUUM aspiri i capelli attraverso la bocchetta di aspirazione e li conservi nel deposito.

1. La modalità MANUALE durerà 5 secondi. A seconda della quantità di capelli, potrebbe essere necessario premere il pulsante di attivazione manuale più di una volta.

2. Quando la manopola di controllo viene ruotata sulla posizione AUTO, aspira i detriti attraverso la bocchetta di aspirazione alla base dell'apparecchio e i sensori rilevano i detriti e avviano automaticamente un ciclo di aspirazione che terminerà una volta che i sensori non rileveranno alcun capello.



REF. 06612



- » Nennleistung: 1400 W
- » Modell: VA001A-BK
- » Nennspannung: 220-240V~
- » Frequenz: 50/60Hz
- » Größe: (Länge x Breite x Höhe): 33 cm Länge x 21 Breite x 56,4 cm Höhe
- » Nettogewicht: etwa 5,1Kg
- » Betriebsgeräusch: ≥83db 1,5m
- » Automatischer Arbeitsmodus: Einführung von Infrarotstrahlung
- » Sog (Zugfestigkeit): ≥2,8 Kg
- » Fassungsvermögen des Behälters: 2,7L MAX
- » Netzkabel Expositionsgröße: 2m

- » Potenza nominale: 1400 W.
- » Modello: VA001A-BK
- » Voltaggio nominale: 220-240V~
- » Frequenza: 50/60Hz
- » Dimensioni: (lunghezza x larghezza x altezza): 33 cm di lunghezza x 21 di larghezza x 56,4 cm di altezza
- » Peso netto: circa 5,1kg
- » Rumore di funzionamento: ≥83db 1,5 m
- » Modalità di lavoro automatica: introduzione di radiazione infrarossa
- » Aspirazione (forza di trazione): ≥2,8 Kg
- » Capacità del serbatoio dell'immondizia: 2,7 L MAX
- » Dimensioni del cavo di alimentazione: 2m

Kämme und bürstenreiniger

Pulitore per pettini e spazzole

1
u.m.vta

6
box



Auf Knopfdruck werden Ihre Bürsten in wenigen Sekunden gereinigt und bieten so einen besseren Service für Sie und Ihre Kunden.

Semplicemente premendo un pulsante, le tue spazzole verranno pulite in pochi secondi, offrendo così un servizio migliore a te e ai tuoi clienti.

- » Leistung: 120W
- » Spart Zeit bei der Reinigung von Bürsten und Kämmen
- » Unterscheiden Sie Ihr Unternehmen durch mehr Hygiene für den Kunden
- » Halten Sie die Bürsten nach jedem Gebrauch sauber
- » Hilft Ihnen, Ihre Arbeit besser zu erledigen

- » Potenza: 120W.
- » Risparmia tempo nella pulizia di spazzole e pettini
- » Distingue la tua attività offrendo maggiore igiene ai clienti
- » Tiene le spazzole pulite dopo ogni utilizzo
- » Aiuta ad eseguire meglio il lavoro

REF. 06954



02

Färbemittel

ACCESSORI
COLORE

*Schüsseln, Haarpinsel, Waagen, Schutzhüllen,
Handschuhe, Aluminiumfolie, Friseurumhang...*

*Ciotole, spatole, bilance, mantelle,
guanti, fogli di alluminio, protettori...*



Zubehör Accessori



REF. 00699



Neutralisierungsschwamm mit Halter
Spugna neutralizzante con sostegno



REF. 00971



Ersatzschwamm
Ricambio della spugna



REF. 03035



Färbelöffel 18 cm
Spatola applicatrice 18 cm

Spezialspatel für Strähnen und Balayage Spatole speciali per meches e balayage

Die Kellen sind ideal für Balayage und kalifornische Strähnen, da sie die Haarsträhnen beim Auftragen des Farbstoffs oder Bleichmittels unterstützen. Balayage ist eine französische Technik, die in den 90er Jahren in Mode kam und mit der man eine gleichmäßige Verteilung der Leichtigkeit im Haar erhält. Das Wort "Balayage" bedeutet "fegen", und gerade durch das Fegen der Farbe von den Wurzeln bis zu den Enden wird ein natürliches und leuchtendes Aussehen erreicht. Dies sind die klassischen kalifornischen Highlights sowohl für Blondinen als auch für Brünette.

Le spatole sono ideali per lavori di balayage e per meches californiane, poiché forniscono supporto per sostenere le ciocche di capelli per applicare il colore o il decolorante. Il balayage è una tecnica francese diventata di moda negli anni '90, con la quale si ottiene una distribuzione uniforme della luminosità nei capelli. La parola "balayage" significa "spazzare" ed è proprio così, spazzando il colore dalle radici alle punte, che si ottiene un aspetto naturale e luminoso. Sono le classiche meches californiane, sia per capelli castani, che per capelli biondi.



REF. 01845



REF. 00977



REF. 02172



Zubehör Accessori

Quetschschlüssel mit Band zum Umhängen
Spremitubetto con laccetto per appendere



1 u.m.vta
100 box

REF. 02537

ROLL-KA Kamm mit Produktapplikator
Pettine ROLL-KA con applicatore di prodotto



1 u.m.vta
6 box

REF. 02680

Tuben Quetsche Spremitubo

Kleine Aluminium-
Quetschpresse
Spremitubo acciaio

1 u.m.vta
12 box

REF. 01959

Kunststoff-Tuben
Quetscher
Spremitubo in plastica

1 u.m.vta
12 box

REF. 03398

Großer Aluminium-
Quetscher
Spremitubo acciaio, grande

1 u.m.vta
10 box

REF. 01496



Tubenquetsche Spremitubo

FarGrandee Tubenpresse
Spremitubo colorato

60 u.m.vta
60 box

REF. 01386

Beutel 10 Metallquetschen
Confezione da 10 spremitubo in metallo



1 u.m.vta
12 box

REF. 02590

Beutel 1 schwarzer Metallquetsche
Sacchetto da 1 spremitubo in metallo nero



12 u.m.vta
240 box

REF. 03521



Schachtel mit 200 verschweißten Spezialstreifen für Strähnen Confezione da 200 fogli termici per meches



REF. 04679



REF. 04679/53



REF. 04679/54



- » 200 Schaumstreifen
- » Widerstandsfähig - leicht - flexibel - thermisch
- » Für schnelles und einfaches Einfärben
- » Erzielen Sie optimale Ergebnisse mit Eurostil-Schaumstreifen
- » Sie ermöglichen es Ihnen, den Farbstoff näher an der Wurzel aufzutragen und die gewünschte Farbe zu erhalten.
- » Hilft, die Glanzeffekte verschiedener Schattierungen mit der Farbe des Papiers, Weiß, Gold und Silber, zu unterscheiden

JEDE FARBE DES PAPIERS WIRD EINER FARBE DER STRÄNDE ENTSPRECHEN:

- » Bei langen Haaren legen Sie einen Streifen unter die Strähne, tragen Sie den Farbstoff auf und falten Sie ihn zusammen, indem Sie die beiden Enden verbinden.
- » Keine Notwendigkeit, die Seiten der Streifen zu biegen
- » Die thermischen Eigenschaften der Eurostil-Streifen beschleunigen den Färbe- oder Verfärbungsprozess. Überprüfen Sie die Entwicklung regelmäßig
- » Selbstklebend: Sie ermöglichen es Ihnen, den Prozess so oft zu kontrollieren, wie Sie wollen

- » 200 fogli in polietilene
- » Resistenti · leggere · flessibili · termiche
- » Per una colorazione facile e veloce
- » Ottieni risultati ottimali con le fogli in polietilene Eurostil
- » Ti permettono di applicare il colore più vicino alla radice e ottenere il colore desiderato
- » Aiutano a differenziare le mechas di diverse tonalità con il colore della carta, bianco, oro e argento
- » Ogni colore della carta corrisponde a un colore delle mechas

CONSIGLI PRATICI PER L'USO:

- » Per i capelli lunghi, posizionare un foglio sotto la ciocca, applicare la tintura e piegarla unendo le due estremità
- » Non è necessario applicare il colore piegare i lati delle fogli
- » Le proprietà termiche delle fogli Eurostil accelerano il processo di colorazione o decolorazione. Controllare regolarmente lo sviluppo dell'effetto
- » Autoadesive: ti permettono di controllare il processo tutte le volte che vuoi

Schachtel mit 100 Strähnen Spezialstreifen 0,8 mm Confezione da 100 fogli speciali per meches 0,8mm



100 Streifen = 63 gr

100 fogli = 63 gr

REF. 03338



Schachtel mit 250 großen 1,1 mm Super-Strähnenblättern Confezione da 250 fogli grandi per supermeches 1,1mm

- » Dicke: 1,1 mm
- » Spessore: 1,1 mm



REF. 01874



Schachtel 100 Stk. Transparent Blätter Confezione da 100 clip trasparenti

Da sie transparent sind, ermöglichen sie es Ihnen, den Prozess mit "bloßem Auge" zu verfolgen, ohne sie öffnen und schließen zu müssen. Dank seines Klebesystems kommt man näher an die Wurzel und es gibt keine Lecks.

Essendo trasparenti, permettono di seguire il processo ad "occhio nudo", senza la necessità di aprire e chiudere. Grazie al loro sistema adesivo non ci sono perdite, essendo più vicine alla radice.



REF. 01025



Digitale Zeitschaltuhr Timer digitale

- » Spannung 9V~
- » Mit Magnethalter
- » Voltaggio 9V~
- » Con supporto e calamita



REF. 02539/50



Zeitschaltuhr Timer



REF. 01975



Digitale EUROSTIL-Waagen Bilance digitali EUROSTIL

- » Spannung 9V~
- » LCD-Anzeige
- » Messbereich bis zu 5 kg
- » Maßeinheit 1 g
- » Maßeinheiten einstellbar auf Kilogramm oder Pfund
- » Tara-Funktion (Bruttogewicht mit Tara-Speicher)
- » Große, stabile Glasauflageplatte für genaues Wiegen
- » Batterien nicht enthalten

- » Verchromte Waage
- » Bilancia cromata

REF. 03337/54

- » Waage matt schwarz
- » Bilancia nera opaca

REF. 03337/50



Digitale EUROSTIL-Waagen

Bilancia digitali EUROSTIL



- » Modernes Design
- » Fassungsvermögen: 5 kg / 11 lbs: 0,4 oz / 176 oz / 5 L
- » Skala: 1gr / 0,1oz / 1 ml
- » Tara-Funktion
- » Automatische Abschaltfunktion
- » Anzeige des Batteriestatus
- » Vier verschiedene Maßeinheiten: g / lb:oz / oz / ml
- » Stromversorgung durch CR2032-Lithiumbatterie (nicht enthalten)

- » Design moderno
- » Capacità: 5 kg / 11 libbre: 0,4 once / 176 once / 5 L
- » Scala: 1gr / 0,1 once / 1 ml
- » Funzione di tara
- » Funzione di spegnimento automatico
- » Indicatore di stato della batteria
- » Quattro diverse unità di misura: g / lb:oz / oz / ml
- » Funziona con batteria al litio CR2032 (non incluso)

- » Schwarze runde digital Waage
- » Bilancia digitale rotonda nera

REF. 04803/50

- » Weiße runde digital Waage
- » Bilancia digitale tonda bianca

REF. 04803/58



- » Schwarze rechteckige Digitalwaage
- » Bilancia digitale rettangolare nera

REF. 04804/50

- » Weiße rechteckige Digitalwaage
- » Bilancia digitale rettangolare bianca

REF. 04804/58



TASSEL Digitalwaage

Bilancia digitale TASSEL



- » Rund
- » Rotonda

REF. 06631



Haarfärbeschale Anti-Rutsch Vaschetta graduata con gomma antiscivolo

32
u.m.v.ta

32
box

» Standard Farben
» Colori standard

300 ml

» Schwarz
» Nero

300 ml

REF. 00647

REF. 00647/50



» Klassische Farben
» Colori classici

300 ml

REF. 00647/98



Haarfärbeschale Anti-Rutsch Vaschetta con gomma antiscivolo

32
u.m.v.ta

32
box

» Transparent
» Trasparente

300 ml

» Durchsichtig
» Semilucida

300 ml

REF. 00647/56

REF. 00647/76



Färbeschüssel Vaschetta per la tintura

72
u.m.vta 72
box

- » Klein
- » Standardfarben

300 ml

REF. 00654

- » Klein
- » Schwarz

300 ml

REF. 00654/50

- » Piccola
- » Colori standard

- » Piccola
- » Nero



11,5 cm

11,5 cm

72
u.m.vta 72
box48
u.m.vta 48
box

- » Klein klassische
Farben

300 ml

REF. 00654/98

- » Groß
- » Durchsichtig

600 ml

REF. 00655/56

- » Piccola
- » Colori classici

- » Grande
- » Semilucida



11,5 cm

14,5 cm

48
u.m.vta 48
box

- » Groß
- » Standard Farben

600 ml

REF. 00655

- » Groß
- » Schwarz

600 ml

REF. 00655/50

- » Grande
- » Colori standard

- » Grande
- » Nero



14,5 cm

14,5 cm



Haarfärbeschale Anti-Rutsch "TERRAZA"
vaschetta antiscivolo "TERRAZA"48
u.m.vta48
box» Durchsichtig
» Semilucida

550 ml

550 ml

REF. 03696

REF. 03696/50

**TASSEL "TERRAZA"- Schale**
Vaschetta TASSEL "TERRAZA"48
u.m.vta48
box**Haarfärbeschale mit Griff**
Vaschetta graduata con manico40
u.m.vta40
box

550 ml

250 ml

REF. 06426

REF. 02340

**Haarfärbeschale mit rutschfestem Gummi und Griff**
Vaschetta graduata con gomma antiscivolo e manico40
u.m.vta40
box

» Durchsichtig

» Metallic Farben

» Semilucida

250 ml

250 ml

REF. 02341

» Colori metallizzati

REF. 02341/97



SAVE abgestufte Haarfärbeschale Vaschetta graduata SAVE

20
u.m.vta

20
box

Plastikschale, die mit einem gestuften Teil versehen ist, um die Menge des Produkts nach Ihren Bedürfnissen zu definieren und so die Entnahme des Produkts zu erleichtern.

Vaschetta in plastica provvista di una parte graduata per stabilire la quantità di prodotto necessaria, facilitandone così la rimozione.

600 ml

REF. 04967/50



REF. 04967

Schale zum Färben und zum Aufhängen am Wagen Vaschetta per tintura da agganciare al carrello

Hängende Farbschale auf einer Fläche von maximal 1,5 cm Dicke. Praktisch für die Anwendung des Färbmittels, welches eine bequeme, schnelle und saubere Anwendung begünstigt. (Siehe Foto im Anhang).

Vaschetta per tintura da agganciare in una superficie massima di 1,5 cm di spessore. Pratico per l'applicazione della tintura, favorendo un'applicazione comoda, veloce e pulita. (Vedi foto allegata).

» Transparent
» Transparente

8
u.m.vta

8
box

700 ml

REF. 01169

» Transparent
» Transparente

14
u.m.vta

14
box

250 ml

REF. 01170



Klein Färbepinsel · Pennelli colore, piccoli

Standard Farben
Colori standard

3,5 cm



20,5 cm

144
u.m.vta144
box1
u.m.vta1
u.m.vta100
box

REF. 00101/01

REF. 00101

Schüttgut
SfusiEinzelverpackt
Confezione individualeSchwarz, mit schwarzen Borsten
Nero, con setole nere

3,5 cm

20,5 cm

REF. 00101/50/01

REF. 00101/50

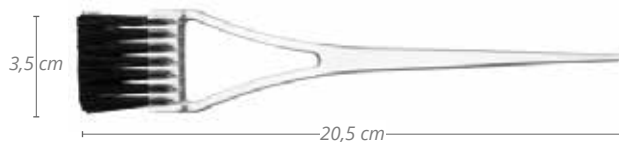
Schüttgut
SfusiEinzelverpackt
Confezione individualeTransparent
Transparente

3,5 cm

20,5 cm

REF. 00101/56/01

REF. 00101/56

Schüttgut
SfusiEinzelverpackt
Confezione individualeMetallic Farben
Colori metallizzati

3,5 cm



20,5 cm

REF. 00101/97

Einzelverpackt
Confezione individualeFarben "klassisch"
Colori "classici"

3 cm



20,5 cm

REF. 00101/98

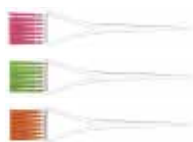
Einzelverpackt
Confezione individualeTransparent mit gefärbten Bündeln
Trasparenti con setole colorate

3 cm



20,5 cm

REF. 00101/56/99

Einzelverpackt
Confezione individuale

Große Färbepinsel · Pennelli colore, grandi

72
u.m.vta72
box1
u.m.vta50
box

REF. 00102/01

REF. 00102

Schüttgut
SfusiEinzelverpackt
Confezione individualeSchwarz, mit schwarzen Borsten
Nero, con setole nere

REF. 00102/50/01

REF. 00102/50

Schüttgut
SfusiEinzelverpackt
Confezione individualeTransparent
Transparente

REF. 00102/56/01

REF. 00102/56

Schüttgut
SfusiEinzelverpackt
Confezione individuale

REF. 00102/97

Einzelverpackt
Confezione individuale

REF. 00102/98

Einzelverpackt
Confezione individuale

REF. 00102/56/99

Einzelverpackt
Confezione individuale

Dose 24 Färbepinsel mod.102
Confezione da 24 pennelli mod.102

REF. 04682

"TERRACE"Pinzel durchscheinend
Pennello semilucido "TERRAZA"

REF. 03697/01

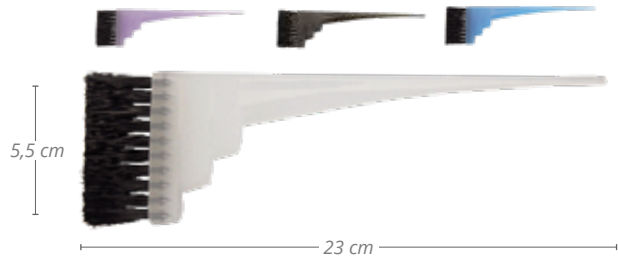

REF. 03697

Schüttgut
SfusiEinzelverpackt
Confezione individuale**TASSEL "TERRAZA" grosser Haarfärbepinsel**
Pennello grande TASSEL "TERRAZA"

REF. 06425

**SOFTLY Haarfärbepinsel mit poliertem Stiel**
Pennello con setole smussate SOFTLY

REF. 04654

Klein
PiccoloEinzelverpackt
Confezione individuale

REF. 04655

Groß
GrandeEinzelverpackt
Confezione individuale

Großer Spezial Haarfärbepinsel
Pennello grande, speciale per colore

REF. 01335

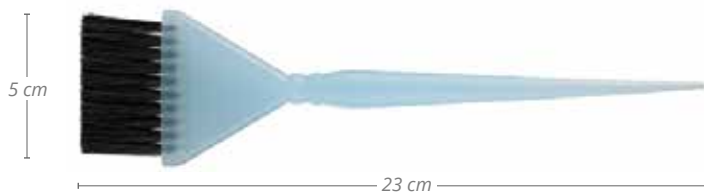
Einzelverpackt
Confezione individuale**Mittelgrosser Spezial Haarfärbepinsel**
Pennello medio speciale per colore

REF. 01280

Einzelverpackt
Confezione individuale**Kleiner Haarfärbepinsel**
Pennello piccolo per colore

REF. 01334

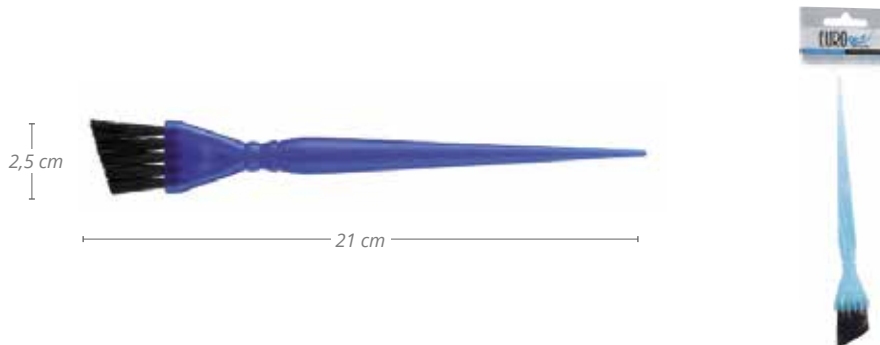
Einzelverpackt
Confezione individuale**Haarfärbepinsel mit Stiel aus Kunststoff**
Spatola con punte in plastica

REF. 03033

Einzelverpackt
Confezione individuale

Haarfärbe Silikonpinsel Spatola colore, in silicone



Silikonkissen für präziseren und schnelleren Farbauftrag:

- » Schnellere Anwendung
- » Näher an der Kopfhaut
- » Größere Produkteinsparungen

Spatola in silicone per l'applicazione del colore in modo più preciso e veloce:

- » Applicazione più veloce
- » Più vicino al cuoio capelluto
- » Maggiore risparmio sui prodotti

REF. 04297

- » Geradlinig und groß
- » Dritta e grande



Einzelverpackt
Confezione individuale

- » Schräg und groß
- » Inclinata e grande



REF. 04298

Einzelverpackt
Confezione individuale

- » Mittlere Spitzen
- » Punte medie



REF. 04299

Einzelverpackt
Confezione individuale

Haarfärbepinsel mit stumpfer Spitze aus Kunststoff Pennello a setole smussate in plastica



REF. 04739



Einzelverpackt
Confezione individuale

Haarfärbepinsel mit Kamm Pennello con pettine



REF. 02529/50



REF. 01128



Nackenschutz Poggiatesta

- » Nackenschutz für Waschbecken
- » Poggiatesta per lavatesta



REF. 01464



- » Silikon mit Saugnapfen
- » In silicone con ventose



REF. 03258



- » Sonderbecken Ondina
- » Lavatesta speciale Ondina



REF. 00979



- » Beutel 2 Stk. schwarze Waschbecken
- » Confezione 2 poggiatesta per lavatesta, neri



REF. 01363



- » Schwarzer Kunststoff-Nackenschutz
- » Poggiatesta, in plastica nera



REF. 02522/50



- » Nackenschutz weich
- » Lavatesta morbido



REF. 02370



- » Nackenschutz aus Silikon für Waschbecken
- » Poggiatesta in silicone, per lavatesta



REF. 04507/60



REF. 04507/59

Comfort



REF. 04507/62



Messbecher mit Skala Misurino graduato

» Messbecher mit Skala
» Misurino graduato

30
u.m.vta

30
box

150 ml

REF. 02530/50



» Modell TERRAZA
» Modello TERRAZZA

32
u.m.vta

32
box

150 ml

REF.04285



» Mit Griff
» Con manico

36
u.m.vta

36
box

100 ml

REF. 00609



24
u.m.vta

24
box

150 ml

REF. 00604



» Mit Griff
» Con manico

16
u.m.vta

16
box

250 ml

REF. 00608

Mischbecher mit Skala aus Kunststoff Shaker graduato in plastica

24
u.m.vta

24
box

160 ml

REF. 01846



18
u.m.vta

18
box

210 ml

REF. 01144



16
u.m.vta

16
box

350 ml

REF. 00978



Messflasche / Applikator Applicatore

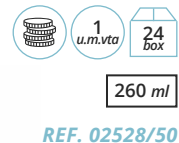
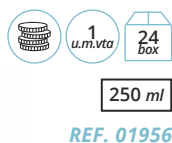
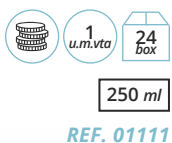
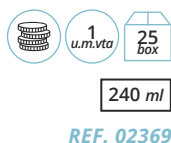
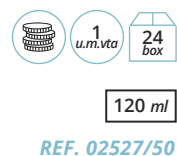

Set mit 3 Trichtern in 3 Mini-Größen Set di 3 imbusti in 3 mini formati

» Für Parfümerie, Friseurhandwerk
» Per profumeria, parrucchiere

REF. 00997

Ø: 3 cm

Ø: 4 cm

Ø: 5 cm



Dosierlöffel Misurino



REF. 01164



Aluminiumfolienrolle farGrande Rotolo di foglio di alluminio colorato

8
u.m.vta8
box

- » Bruttogewicht: 600 gr
- » Nettogewicht ohne Dorn: 537 gr
- » Dicke: 12 Mikrometer +/-

- » Peso lordo: 600 gr
- » Peso netto senza tubo: 537 gr
- » Spessore: 12 micron +/-

125 m
Aprox

- » Bruttogewicht: 475 gr
- » Nettogewicht ohne Dorn: 425 gr
- » Dicke: 15 Mikrometer +/-

- » Peso lordo: 475 gr
- » Peso netto senza tubo: 425 gr
- » Spessore: 15 micron +/-

6
u.m.vta6
box100 m
Aprox

Mit einer sehr scharfen
eingebauten Klinge
Con lama per taglio molto
affilata incorporata



Aluminium-Folienrolle Alufolienrolle Rotolo alluminio

6
u.m.vta6
box

- » Bruttogewicht: 600 gr
- » Nettogewicht ohne Dorn: 537 gr
- » Dicke: 10 Mikrometer +/-

- » Peso lordo: 600 gr
- » Peso netto senza tubo: 537 gr
- » Spessore: 10 micron +/-

118 m
Aprox

REF. 01139



Aluminium-Folienrolle Alufolienrolle Rotolo alluminio

Mit transparentem Streifen
Con striscia trasparente

6
u.m.vta6
box60 m
Aprox

REF. 02531



PVC-Folienrolle Rotolo PVC con tubo

6
u.m.vta6
box210 m
Aprox

REF. 01198



Geprägtes Aluminium Fogli di alluminio goffrato

- » 18 Mikrometer Silberaluminium, ausgezeichnete Qualität und Prägung
- » Mit Klebelasche und 200 Blatt
- » Dank seiner Prägung atmet das Haar mehr bei der Realisierung der Strähnen und Färbungen, für ein besseres Ergebnis der geleisteten Arbeit.

- » *Alluminio argentato brillante di alta qualità, 18 micron, goffrato*
- » *200 fogli con linguetta adesiva*
- » *Grazie alla goffratura, i capelli respirano di più quando si eseguono le meches e le tinture, favorendo un miglior risultato del lavoro svolto*



REF. 06079

- » Glanzsilberfarbenes Aluminium. Mit Klebelasche und 100 Blatt
- » Dank der Prägung des Aluminiums und seiner leichten visuellen Charakteristik erlaubt es, die geleistete Arbeit zu visualisieren, ohne das Papier öffnen und schließen zu müssen, was die Arbeit des Fachmanns erleichtert und beschleunigt.

- » *Alluminio argentato lucido. 100 fogli con linguetta adesiva*
- » *Grazie alla goffratura dell'alluminio, e alla sua caratteristica visual light, permette di visualizzare il lavoro in esecuzione senza la necessità di aprire e chiudere la carta, facilitando e velocizzando il lavoro del professionista*



REF. 06080

- » Hervorragende Qualität und geprägte, Aluminiumfolienrolle von etwa 18 Mikrometer und einem Bruttogewicht von 400 gr
- » Dank seiner Prägung atmet das Haar bei der Realisierung der Strähnen und Färbungen mehr, was ein besseres Ergebnis der durchgeführten Arbeit begünstigt
- » 9 Meter lang und 12 cm breit

- » *Rotolo di foglio di alluminio di ottima qualità e goffrato di circa 18 micron e peso lordo di 400 gr*
- » *Grazie alla goffratura, i capelli respirano di più quando si eseguono le meches e le tinture, favorendo un miglior risultato del lavoro*
- » *9 metri di lunghezza per 12 cm di larghezza svolto*



REF. 06081

- » Schachtel mit 300 Blatt
- » Dispenser da 300 fogli



REF. 06193



Spender Dispenser



REF. 02426

Schutzbeutel Protettori

- » Beutel 180 u.
- » Schutz für Brillen
bügel

- » Sacchetto da 180 unità
- » Protettore per occhiali



REF. 03217

- » Beutel 50 Stk.
- » Schutzbeutel für die
Stuhllehne

- » Sacchetto da 50 unità
- » Protezione per lo
schienale della sedia

5,4 x 5,5 x 2,3 cm



REF. 03634

- » Schachtel 200 Stk. Handy-Schutz
- » Confezione da 200 unità Protettore cellulare



REF. 03633

- » Beutel 2 Stk. Ohrschutz
- » Sacchetto da 2 unità Protezione per le orecchie



REF. 01915



Ohrschutz 50 Stk Protezione per le orecchie 50 unità

- » Abmessungen: 2*4,5 cm
- » Gewicht: 0,40 gr
- » Material: Kunststoff

- » Dimensioni: 2*4,5 cm
- » Peso: 0,40 gr
- » Materiale plastico



REF. 07008

Beutel mit 100 Einweghandschuhen Confezione da 100 guanti monouso

NEW



REF. 07304



Beutel mit 200 Plastikhandschuhen Confezione da 200 guanti di plastica



REF. 00963



100 HANDSCHUHE PE zum einmaligen Gebrauch und für eine astreine Hygiene**100 Guanti pe monouso**

REF. 07257

- » Beidhändig
- » Einheitsgröße
- » Multifunktional

- » *Ambidestro consente a ciascun guanto di essere usato per qualsiasi mano*
- » *Taglia unica*
- » *Multiuoso*



NEW

100 transparente Polyethylenhandschuhe**100 Guanti polietilene trasparenti**

REF. 07804

- » 100% reines Polyethylen HDPE 0,7+/2%g/pc
- » Hypoallergen, undurchlässig, Einheitsgröße
- » EPI Handelsklasse 1, angefertigt und gekennzeichnet CE
- » Kompatibel mit Lebensmittelgebrauch 2011/10/CE
- » 30 cm. hoch x 25 cm. Breit – Finger 15 cm breit Handgelenk

- » *Polietilene hdpe 100% 0,7 +/- 2% g / pz*
- » *Anallergici, impermeabile, taglia unica,*
- » *DPI di categoria 1, prodotti e marcati CE,*
- » *Compatibile con uso alimentare 2011/10 / CE*
- » *30 Cm altezza x 25 cm larghezza x 15 larghezza polso 15*



NEW

Beutel 2 Stk. professionelle Handschuhe**Sacchetto 2 unità guanti professionali**

- » Material: Gummi
- » *Materiale: gomma*

6,5
Talla / Size

REF.01672

7
Talle / Size

REF.01673

7,5
Talla / Size

REF.01674

8
Talla / Size

REF.01675

Box 100 schwarze Nitril-Handschuhe**Scatola da 100 guanti in nitrile nero**NITRIL / NITRILE
AQL 1,5

- » *Ohne Pulver*
- » *SENZA polvere*



S

REF. 06686

M

REF. 06687

L

REF. 06688

Karton 50 synthetische Handschuhe

Confezione da 50 guanti sintetici



Ohne Pulver
SENZA polvere

- » Verbindet die Flexibilität von Latex und die Elastizität des geruchslosen Vinyls.
- » Gefühl einer zweiten Haut, dank ihrer elastischen Eigenschaften, sehr ähnlich wie beim Latex, und bietet die hypoallergenen Eigenschaften des Vinyls.
- » Material: PVC-Derivat.
- » Nicht steril
- » Farbe schwarz
- » Innen- und Außenoberfläche glatt
- » Geeignet für Latex-Allergiker

- » *Combinano la flessibilità del lattice e l'elasticità del vinile inodore.*
- » *Sensazione di seconda pelle grazie alle sue proprietà elastiche molto simili al lattice e alle proprietà ipoallergeniche del vinile.*
- » *Materiale: derivato del PVC*
- » *Non sterili*
- » *Colore nero*
- » *Superfici interne ed esterne lisce.*
- » *Adatti agli allergici al lattice.*

NEW



M

REF. 07263

L

REF. 07264

Schachtel mit 20 schwarzen Latexhandschuhen

Confezione da 20 guanti in latex

LATEX / LATEX
AQL 1,5

Ohne Pulver
SENZA polvere



S

REF. 02832

M

REF. 02833

L

REF. 02834

Schachtel mit 100 weißen Latexhandschuhen mit wenig Puder

Confezione da 100 guanti in latex bianco con poco talco

LATEX / LATEX
AQL 1,5

S/M

REF. 01671

S/M

REF. 01669

S/M

REF. 01670

Schachtel mit 100 Vinyl-Handschuhen

Confezione da 100 guanti in vinile

VINYL / VINILE
AQL 1,5

Ohne Pulver
SENZA polvere



S

REF. 02586

M

REF. 02587

L

REF. 02588

Eurostil-Gummi Nackenumhang
 Coprispalle in gomma Eurostil

REF.01350

BOB-TUO Gummi Nackenumhang
 Coprispalle in gomma BOB-TUO



REF.01082

Professioneller Silikon Nackenumhang
 Coprispalle professionale in silicone

REF. 03735

Nackenumhang mit magnetischem Verschluss
 Coprispalle con chiusura magnetica

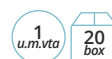
REF.02496

Professioneller Nackenumhang
 verstärkt
 Coprispalle professionale rinforzato

REF.00666/50

Nackenumhang mit magnetischem Verschluss
 Coprispalle con chiusura magnetica

REF. 02518/50



REF. 02519/50



REF. 02519/54

Silikon Nackenumhang mit magnetischem Verschluss EUROSTIL
Coprispalle con chiusura magnetica Coprispalle EUROSTIL in silicone



REF.07006



Professioneller Friseurumhang
Coprispalle professionale

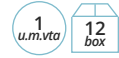

- » Werkstoff: Nylon
- » Klett-Verschluss
- » Materiale: nylon
- » Chiusura in velcro

REF.02595/50

REF.02595/58

REF.02595/70

REF.02595/59



Ø: 80 cm



- » Werkstoff: Nylon
- » Klett-Verschluss
- » Materiale: nylon
- » Chiusura in velcro

REF.02598/68

REF.02598/64

REF.02598/75

Ø: 80 cm



115 cm

84 cm



Beutel 50 einweschürzen Confezione 50 mantelle monouso

- » Material: PE
- » Dicke: ca. 18 Mikrometer
- » Gewicht pro Schürze 10 g
- » Schürze für nur einen Gebrauch
- » Ideal zum Schutz der Kleidung
- » Einmaliger Gebrauch für eine untadelige Hygiene

- » Materiale: PE
- » Spessore 18 micron circa
- » peso ogni grembiule 10g
- » Grembiule monouso ideale per proteggere i vestiti.
- » Monouso per un'igiene impeccabile



REF. 07266

NEW

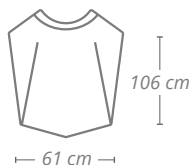

Beutel mit 30 umhängen schwarz Confezione 30 mantelle monouso

- » Material: Polyethylen niedriger Dichte LDPE
- » Dicke des Kunststoffs 20 Mikrometer
- » Verschluss durch Schlaufe
- » Gewicht 340 g

- » Materiale: Polietilene LDPE a bassa densità
- » Spessore plastica 20 micron
- » Chiusura con laccio
- » Peso 340 g



REF. 01078

NEW

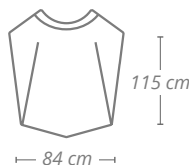

Beutel 30 Capes schwarz confezione da 30 mantelline nere

- » Einmaligen Gebrauch
- » Monouso



REF. 07243

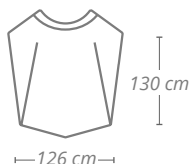

NEW



Packung 50 Einweg Umhänge Confezione da 50 mantelline monouso

- » Material P.E
- » Schleifenverschluss
- » Dicke: ca. 12,5 Mikrometer

- » Materiale P.E
- » Chiusura con laccio
- » Spessore 12,5 micron circa



REF. 07806/50

REF. 07806/58

REF. 07806/59



CLASSIC-Beutel mit 30 Umhängen
Confezione da 30 mantelline CLASSIC

- » Material: Kunststoff
- » Schleifenverschluss
- » Dicke: ca. 14 Mikrometer

» Materiale: plastica

- » Chiusura con laccio
- » Spessore 14 micron circa

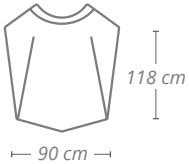

REF.02791/58



REF.02791/50



REF.02791/54



REF.02791/59



REF.02791/64



REF.02791/68



REF.02791/70



REF.02791/53

Packung 50 Umhänge SIMPLE - Confezione da 50 mantelline SIMPLE



REF. 01207

- » Material: Kunststoff
- » Schleifenverschluss
- » Blau

» Materiale: plastica

- » Chiusura con laccio
- » Blu

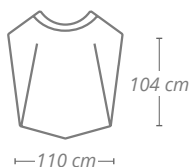

Packung 30 Umhänge TASSEL Confezione da 30 mantelline TASSEL

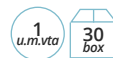

REF. 06427

- » Material: Kunststoff
- » Schleifenverschluss
- » Weiß

» Materiale: plastica

- » Chiusura con laccio
- » Bianco

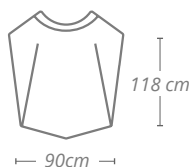

Packung 50 Einweg Umhänge Confezione da 50 mantelline monouso



REF. 02456/58

REF. 02456/59

- » Material P.E
- » Schleifenverschluss
- » Dicke: ca. 12,5 Mikrometer

- » Materiale P.E
- » Chiusura con laccio
- » Spessore 12,5 micron circa

REF. 02456/60

REF. 02456/64

REF. 02456/68

REF. 02456/70

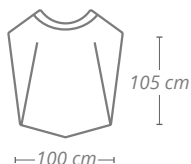

Beutel mit 30 Umhängen in Weiß Confezione da 30 mantelline WHITE



REF. 06113/58

- » Material: Polyethylen
- » Schleifenverschluss
- » Dicke: ca. 11 Mikrometer
Mit Aufhänger

- » Materiale: polietilene
- » Chiusura con laccio
- » Spessore 11 micron circa
- » Per appendere



Rolle 50 Umhänge zum einmaligen Gebrauch
Rotolo da 50 mantelline monouso

12
u.m.vta

12
box

- » Material P.E
- » Schleifenverschluss
- » Dicke: ca. 12,5 Mikrometer

REF. 02792/58

REF.02792/50

- » Materiale P.E
- » Chiusura con laccio
- » Spessore 12,5 micron circa

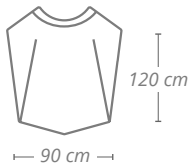

REF. 02792/59

Cape Polyester schwarz, mit Ärmeln
Mantellina in poliestere nero con maniche

1
u.m.vta

12
box

- » Material:100% Polyester
- » Hakenverschluss

REF. 07122

- » Materiale: 100% poliestere
- » Chiusura a gancio



MYSTERY Umhang Mantellina MISTERY

1
u.m.vta

6
box

- » Material: 76% Polyester, 24% P.U.
- » Klett-Verschluss
- » Wasserabweisend

REF. 02505/61

REF. 02505/69

- » Material: Kunststoff
- » Klett-Verschluss
- » Wasserabweisend

REF. 02506/50

- » Materiale: 76% poliester, 24% PU
- » Chiusura in velcro
- » Idrorepellente

- » Materiale: plastica
- » Chiusura in velcro
- » Idrorepellente

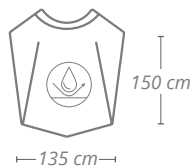
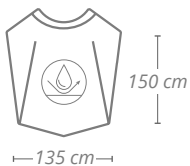

FACES 2019 Umhang Mantellina FACES 2019

1
u.m.vta

12
box

- » Material: Polyester
- » Klett-Verschluss

REF. 02501/50

REF. 02501/73

- » Materiale: poliester
- » Chiusura in velcro

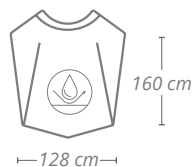

LOOK Umhang Mantellina LOOK

1 u.m.vta
12 box

- » Material: 100% Polyester
- » Bügelverschluss
- » Wasserabweisend
- » Antistatisch

- » Materiale: 100% poliestere
- » Chiusura con gancetti
- » Idrorepellente
- » Privo di elettricità statica

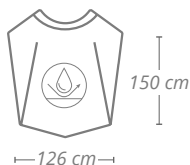

REF. 02504/75

REF. 02504/50

REF. 02504/68



NIGHT Umhang Mantellina NIGHT

1 u.m.vta
12 box

- » Material: Nylon
- » Knopf-Verschluss

- » Materiale: nylon
- » Chiusura a bottone

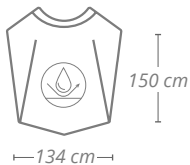

REF. 02503/50

REF. 02503/58

REF. 02503/75



REF. 02503/72

REF. 02503/68

REF. 02503/62

REF. 02503/60



SCISSORS-Umhang Mantellina SCISSORS

1
u.m.vta

12
box

- » Material: 100% PVC
- » Klett-Verschluss
- » Wasserabweisend

- » Materiale: 100% PVC
- » Chiusura in velcro
- » Idrorepellente

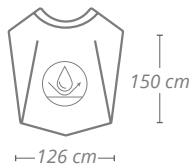

REF. 01842/68



REF. 01842/50

REF. 01842/59

REF. 01842/73



MODELL Umhang Mantellina MODEL

1
u.m.vta

12
box

- » Material: 100% Polyester
- » Klett-Verschluss
- » Wasserabweisend

- » Materiale: 100% poliestere
- » Chiusura in velcro
- » Idrorepellente

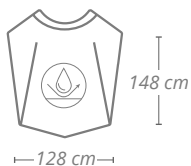

REF. 04303/50



REF. 04303/59



REF. 04303/72

BOB-Umhang Mantellina BOB

1
u.m.vta

12
box

- » Material: Polyester
- » Klettverschluss
- » Wasserabweisend

REF. 02632/59

REF. 02632/72

- » Materiale: poliester
- » Chiusura con gancetti
- » Idrorepellente

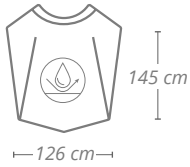

FACES 2000 Umhang Mantellina FACES 2000

1
u.m.vta

12
box

- » Material: Nylon
- » Klett-Verschluss
- » Wasserabweisend

REF. 01961/50

REF. 01961/59

- » Materiale: nylon
- » Chiusura in velcro
- » Idrorepellente

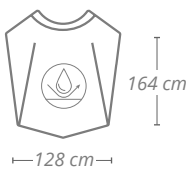

EUROSTIL Umhang
Mantellina EUROSTIL1
u.m.vta 12
box

REF. 04257/50

- » Material: Nylon
- » Knopf-Verschluss

- » Wasserabweisend

- » Materiale: nylon
- » Chiusura a bottone
- » Idrorepellente

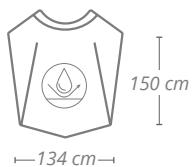
**BEAUTY Umhang**
Mantellina BEAUTY1
u.m.vta 12
box

REF. 04311

- » Material: 100% Polyester
- » Klett-Verschluss
- » Wasserabweisend

- » Materiale: 100% poliestere
- » Chiusura in velcro
- » Idrorepellente

**PLACTON Umhang für Färbearbeiten**
Mantellina PLACTON1
u.m.vta 50
box

- » Werkstoff: PVC
- » Klett-Verschluss

- » Materiale: PVC
- » Chiusura in velcro

REF. 01988/73

REF. 01988/50

REF. 01988/59

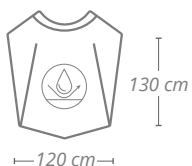

ANIMAL PRINT Umhang

Mantellina ANIMAL PRINT

1
u.m.vta

12
box

- » Werkstoff: Nylon
- » Klett-Verschluss

- » Materiale: nylon
- » Chiusura in velcro

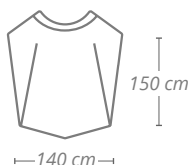

REF. 02502/58



- » Werkstoff: Nylon
- » Klett-Verschluss

- » Materiale: nylon
- » Chiusura in velcro



REF. 03522



REF. 02502/61



REF. 03523



ZEBRA Umhang

Mantellina ZEBRA

1
u.m.vta

12
box

- » Werkstoff: Nylon
- » Klett-Verschluss

- » Materiale: nylon
- » Chiusura in velcro

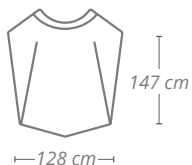

REF. 03524



DAY Umhang Mantellina DAY

- » Material: 65% Polyester
- » 35% Baumwolle
- » Klettverschluss

- » Materiale: 65% poliestere 35% cotone
- » Chiusura in velcro

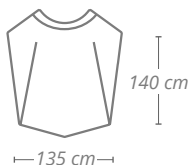

REF. 01077/58

REF. 01077/50



ELEGANT Umhang Mantellina ELEGANT

- » Material: 100% Polyester
- » Klett-Verschluss

- » Materiale: 100% poliestere
- » Chiusura in velcro

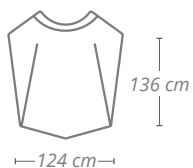

REF. 01175/60

REF. 01175/50

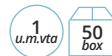

REF. 01175/58

REF. 01175/59

REF. 01175/72



BROSS-Umhang Mantellina BROSS

» Material: Kunststoff
» Klett-Verschluss

» Materiale: plastica
» Chiusura in velcro

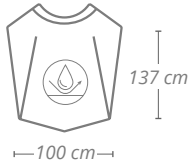

REF. 01228

» Material: Kunststoff
» Klett-Verschluss

» Materiale: plastica
» Chiusura in velcro

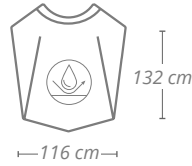

REF. 01774



LIGHTS Umhang Mantellina LIGHTS

» Material: Nylon
» Knopf-Verschluss

» Materiale: nylon
» Chiusura a bottone

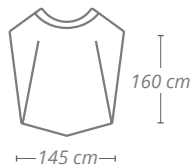

REF. 04877/54

REF. 04877/63

REF. 04877/68



STYLE Umhang
Mantellina STYLE1
u.m.vta50
box

- » Material: Nylon
- » Knopf-Verschluss

- » Materiale: nylon
- » Chiusura a bottone

REF. 04876/68

REF. 04876/50

REF. 04876/58

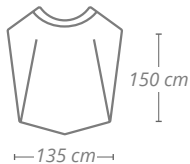
**FUNNY Umhang**
Mantellina FUNNY1
u.m.vta50
box

- » Material: Polyurethan und Polyester
- » Knopf-Verschluss
- » Wasserabweisend

- » Materiale: poliuretano e poliestere
- » Chiusura a bottone
- » Idrorepellente

REF. 04879/50

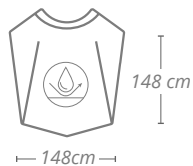
**GirovitaLINE Umhang**
Mantellina GirovitaLINE1
u.m.vta12
box

- » Material: 65% Polyester, 35% Baumwolle
- » Klett-Verschluss
- » Schneiden und Färben

- » Materiale: 65% poliestere, 35% cotone
- » Chiusura in velcro
- » Taglio e tintura

REF. 01076/50

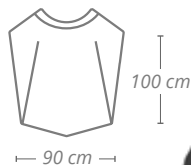

Schwarzer Mantel Camice nero



REF. 04301

- » Material: 100% Polyester
- » Knopf-Verschluss

- » Materiale: 100% poliestere
- » Chiusura a bottone



Schulter: 47 cm
Ärmel: 25 cm
Büste: 117 cm
Länge: 72 cm

Spalle: 47 cm
Manica: 25 cm
Giro del busto:
117 cm
Lunghezza: 72 cm

Kimono Kimono

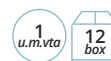

REF. 04300

- » Material: 100% Polyester
- » Knopf-Verschluss

- » Materiale: 100% poliestere
- » Chiusura a bottone



Schulter: 70 cm
Büste: 122 cm
Länge: 106 cm

Spalle: 70 cm
Giro del busto:
122 cm
Lunghezza:
106 cm

Transparente Schürze Grembiule trasparente



REF. 01929

- » Material: Durchsichtiges PVC
- » Schleifenverschluss
- » Schwarzer Rand
- » Wasserabweisend

- » Materiale: PVC trasparente
- » Chiusura con laccio
- » Bordo nero
- » Idrorepellente

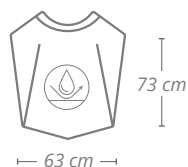

LONG Schürze Grembiule LONG



REF. 04880/50

- » Material: 100% Nylon
- » Schleifenverschluss
- » Wasserabweisend
- » Schwarz

- » Materiale: 100% nylon
- » Chiusura con laccio
- » Idrorepellente
- » Nero

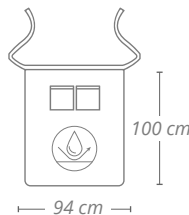

Schwarze Schürze Grembiule nero

- » Material: 100% Polyester
- » Schleifenverschluss
- » Wasserabweisend

- » Materiale: 100% poliestere
- » Chiusura con laccio
- » Idrorepellente

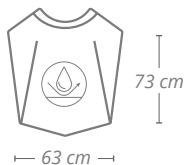

REF. 04305

Schürze mit Tasche Grembiule con tasca

- » Material: 100% Polyester
- » Schleifenverschluss
- » Wasserabweisend

- » Materiale: 100% poliestere
- » Chiusura con laccio
- » Idrorepellente

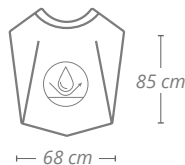

REF. 04302

Arbeitsschürze Grembiule

- » Material: 24% Polyurethan, 76% Polyester
- » Klett-Verschluss
- » Wasserabweisend

- » Materiale: 24% poliuretano, 76% poliestere
- » Chiusura in velcro
- » Idrorepellente

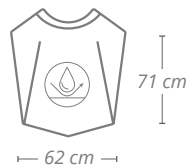

REF. 02510/50

Kinder-Umhang Katzen Mantellina per bambini, gatti

1
u.m.v.ta

12
box

- » Material: 100% Polyester
- » Klett-Verschluss
- » Wasserabweisend

- » Materiale: 100% poliestere
- » Chiusura in velcro
- » Idrorepellente

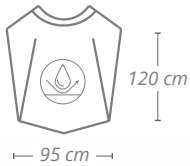

REF. 04313/68

REF. 04313/64



Kinder-Umhang Enten Mantellina per bambini, papere

1
u.m.v.ta

12
box

- » Material: 100% Polyester
- » Klett-Verschluss

- » Materiale: 100% poliestere
- » Chiusura in velcro

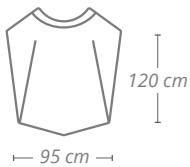

REF.02509/70



Kinder-Umhang Hunde

Mantellina per bambini, cani

- » Material: 100% Polyester
- » Klett-Verschluss

- » Materiale: 100% poliestere
- » Chiusura in velcro

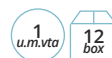
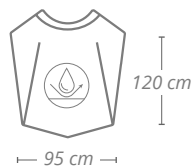

REF.02508/75



REF.02508/70



REF.02508/61



Lustige Designs in verschiedenen Drucken und Farben
Disegni molto divertenti in diversi modelli e colori

Professionelle Berufsbekleidung Abbigliamento professionale

* Nicht verfügbar für Portugal
* Non disponibile per il Portogallo

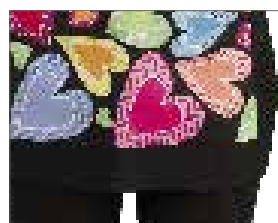
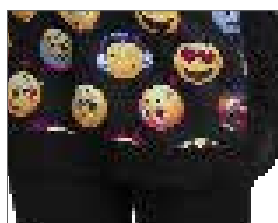

www.eurostil.com



Herz-Kasack
Camice con cuori**MOD. 51605128**

Mini-Kasack mit Brustklammer und Mao-Kragen. Enthält 1 Vordertasche, 1 bedruckte Tasche und 1 unbedruckte Tasche. Geknüpft mit farGrandeen Knöpfen, tailliertes Kleidungsstück mit Clips und seitlichen Öffnungen.
100% Polyester

Camice con maniche ad aletta, clip sul petto e colletto alla coreana. 1 tasca frontale, 1 tasca color fantasia e un'altra in tinta unita. Chiusura con bottoni colorati, capo aderente con pinces e aperture laterali.
100% poliester

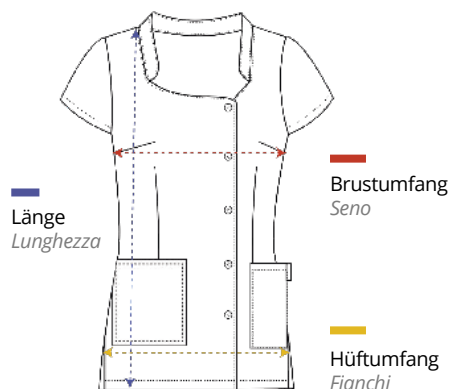

S
98 - 102 cm
102 - 106 cm
72 - 74 cm

REF.06297/50/1

M
106 - 110 cm
108 - 112 cm
73 - 75 cm

REF.06297/50/2

L
114 - 118 cm
116 - 120 cm
75 - 77 cm

REF.06297/50/3

XL
120 - 124 cm
124 - 128 cm
77 - 79 cm

REF.06297/50/4

XXL
126 - 130 cm
136 - 140 cm
78 - 80 cm

REF.06297/50/5

MOD. 51605128

Mini-Kasack mit Brustklammer und Mao-Kragen. Enthält 1 Vordertasche, 1 bedruckte Tasche und 1 unbedruckte Tasche. Geknüpft mit farGrandeen Knöpfen, tailliertes Kleidungsstück mit Clips und seitlichen Öffnungen.
100% Polyester

Camice con maniche ad aletta, clip sul petto e colletto alla coreana. 1 tasca frontale, 1 tasca color fantasia e un'altra in tinta unita. Chiusura con bottoni colorati, capo aderente con pinces e aperture laterali.
100% poliester

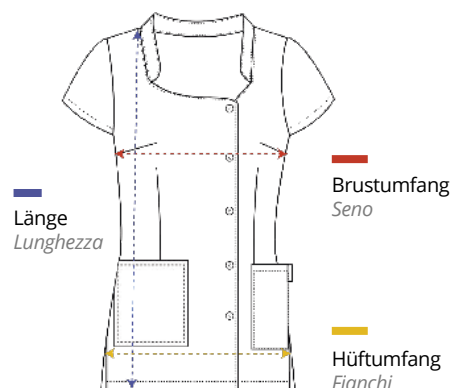

S
98 - 102 cm
102 - 106 cm
72 - 74 cm

REF.06297/58/1

M
106 - 110 cm
108 - 112 cm
73 - 75 cm

REF.06297/58/2

L
114 - 118 cm
116 - 120 cm
75 - 77 cm

REF.06297/58/3

XL
120 - 124 cm
124 - 128 cm
77 - 79 cm

REF.06297/58/4

XXL
126 - 130 cm
136 - 140 cm
78 - 80 cm

REF.06297/58/5

Frauen Kasack farGrande
Camice colorato

1 u.m.vta 40 box

MOD. 51505003

Brust- und Rücken Kasack mit quadratischem Dekolleté. Diagonaler Druck mit YKK-Reißverschluss und einer Tasche. Passendes Kleidungsstück mit Falten und Seitenschlitzen. 100% Polyester

Camice con pince sul petto e sulla schiena e scollatura quadrata. Fantasia in diagonale con zip YKK, giromanica e una tasca. Capo aderente con pince e aperture laterali. 100% poliester



Länge
Lunghezza

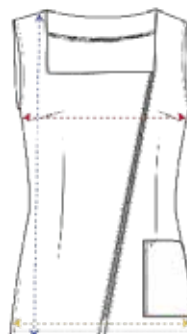

Brustumfang
Seno

Hüftumfang
Fianchi

S

88-92 cm
100-104 cm
69-71 cm

REF.06296/50/1

M

94-98 cm
100-108cm
71-73 cm

REF.06296/50/2

L

102-106 cm
110-114 cm
73-75 cm

REF.06296/50/3

XL

108-112 cm
120-124 cm
74-76 cm

REF.06296/50/4

XXL

118-122 cm
130-134 cm
75-77 cm

REF.06296/50/5

Kasack Lippenstift mit Reißverschluss
Camice fantasia rossetto con zip

1 u.m.vta 40 box

MOD. 51308060

Kasack mit Brustverschluss, Rücken und Dekolleté quadratischem Ausschnitt. 1 bedruckte Vorderseite, seitlicher YKK-Reißverschluss, und eine Tasche, tailliertes Kleidungsstück mit Abnähern und Seitenschlitzen.

Camice con pince sul petto e sulla schiena e scollatura quadrata. 1 stampa fantasia frontale, cerniera YKK, giromanica e tasca a filetto, capo aderente con pince e aperture laterali.



Länge
Lunghezza

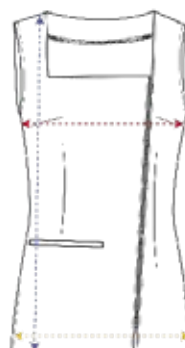

Brustumfang
Seno

Hüftumfang
Fianchi

S

88-92 cm
100-104 cm
69-71 cm

REF.06299/50/1

M

94-98 cm
100-108cm
71-73 cm

REF.06299/50/2

L

102-106 cm
110-114 cm
73-75 cm

REF.06299/50/3

XL

108-112 cm
120-124 cm
74-76 cm

REF.06299/50/4

XXL

118-122 cm
130-134 cm
75-77 cm

REF.06299/50/5

Kasack farGrandee Kreise
Camice a pois colorati1 u.m.vta
40 box

MOD. 51505005

Einfache ärmelloser Kittel mit bedrucktem Streifen. YKK-Reißverschluss an der Seite. Zusammensetzung 100% Polyester. Zwei Taschen, eine auf der Taille und eine auf der Brust. Empfohlen für Geschäfte und Schönheitssalons.

Camice colorato basic con fascia stampata. Chiusura con zip YKK sul lato. Materiale: 100% poliestere Due tasche, una in vita e una sul petto. Consigliato per negozi e centri estetici.

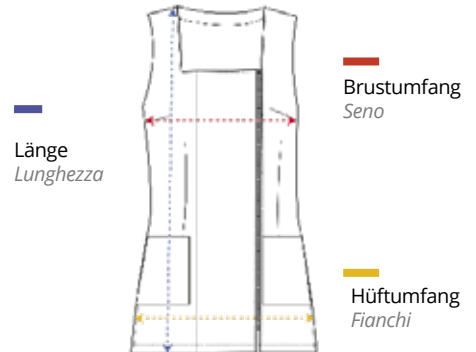

S

88-92 cm
100-104 cm
69-71 cm

REF. 06304/50/1

M

94-98 cm
100-108cm
71-73 cm

REF. 06304/50/2

L

102-106 cm
110-114 cm
73-75 cm

REF. 06304/50/3

XL

108-112 cm
120-124 cm
74-76 cm

REF. 06304/50/4

Kasack schwarz
Camice nero1 u.m.vta
40 box

MOD. 51605126

Einfache ärmelloser Kittel mit bedrucktem Streifen. YKK-Reißverschluss an der Seite. Zusammensetzung 100% Polyester. Zwei Taschen, eine auf der Taille und eine auf der Brust. Empfohlen für Geschäfte und Schönheitssalons.

Camice colorato basic con fascia stampata. Chiusura con zip YKK sul lato. Materiale: 100% poliestere Due tasche, una in vita e una sul petto. Consigliato per negozi e centri estetici.

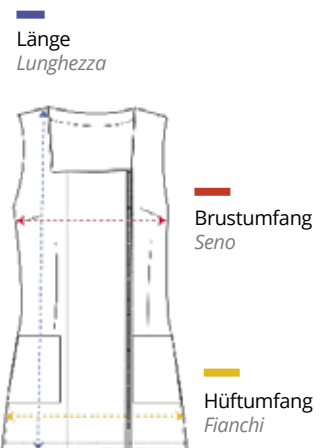

S

88-92 cm
100-104 cm
69-71 cm

REF. 06556/50/1

M

94-98 cm
100-108cm
71-73 cm

REF. 06556/50/2

L

102-106 cm
110-114 cm
73-75 cm

REF. 06556 /50/3

XL

108-112 cm
120-124 cm
74-76 cm

REF. 06556 /50/4

XXL

118-122 cm
130-134 cm
75-77 cm

REF. 06556/50/5

Kasack Kurzärmel aus Polyester mit Reißverschluss
Camice in poliestere a manica corta con zip

1 u.m.vta
40 box

MOD. 51308455N

Die Maße sind annähernd und gehören zum fertigen Kleidungsstück der Gesamtkontur. Sie müssen zwischen 4 und 6 cm je nach Größe der Person für den losen Sitz hinzufügen.

Le misure sono approssimative e riguardano il perimetro complessivo del capo. Alla misura della persona bisogna si devono invece aggiungere tra i 4 e i 6 cm per un uso confortevole.

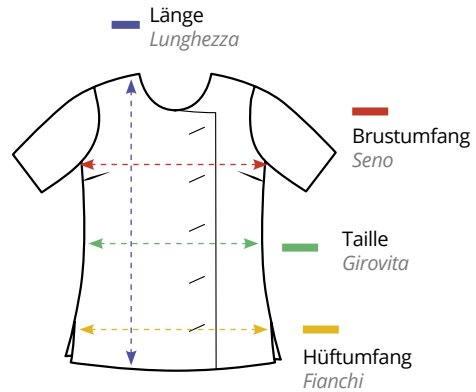

XS	S	M	L	XL	2XL
86 cm	92 cm	98 cm	106 cm	114 cm	122 cm
92 cm	98 cm	104 cm	111 cm	119 cm	127 cm
71 cm	72 cm	73 cm	74 cm	76 cm	77 cm
82 cm	88 cm	93 cm	101 cm	109 cm	116 cm
REF.07146/1	REF.07146/2	REF.07146/3	REF.07146/4	REF.07146/5	REF.07146/6

Kasack Ärmellos mit Gesicht
Camice senza maniche fantasia viso

1 u.m.vta
40 box

MOD. 51805322

Die Maße sind annähernd und gehören zum fertigen Kleidungsstück der Gesamtkontur. Sie müssen zwischen 4 und 6 cm zur Größe je Person für den losen Sitz hinzufügen.

Le misure sono approssimative e riguardano il perimetro complessivo del capo. Alla misura della persona si devono invece aggiungere tra i 4 e i 6 cm per un uso confortevole.



XS	S	M	L	XL	2XL
90 cm	96 cm	102 cm	110 cm	118 cm	126 cm
98 cm	104 cm	110 cm	117 cm	125 cm	133 cm
71 cm	72 cm	73 cm	74 cm	76 cm	77 cm
83 cm	89 cm	95 cm	102 cm	110 cm	118 cm
REF.07145/1	REF.07145/2	REF.07145/3	REF.07145/4	REF.07145/5	REF.07145/6

Frauen Kittelschürze Stola / Herzen
Camice fantasia cuori / silhouette

Enganliegende Kittel mit rundem Halsausschnitt und Armausschnitten in lebendigen bunten Farben. Einfaches Vorderteil mit zentraler bedruckter Teilungstasche, abgerundetem Saum und Taillen Anpassung mit Bändern, die über den Rücken laufen und in der Taille geknotet werden. 100% Polyester

Camice aderente dai colori accesi e giromanica semplice. Parte frontale superiore in tinta unita con tasca divisoria con stampa centrale, orli stondati e regolazione del girovita con fasce che passano dalla schiena e si allacciano in vita. 100% poliestere



MOD. 2150206
REF.06305/50

MOD. 21602109
REF.06306/50

MOD. 21304421
REF.06307/50

MOD. 21502001
REF.06308/50

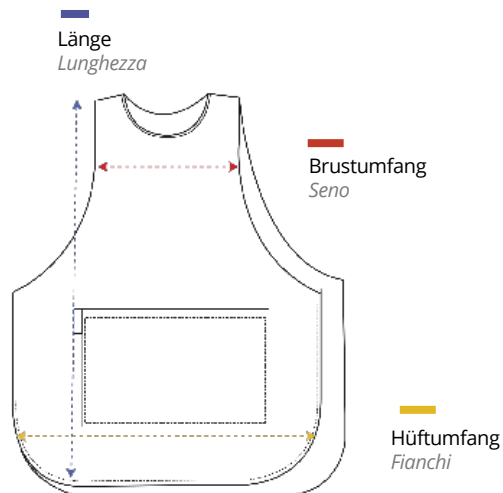

35 cm
50 cm
77 cm

Schürzenkittel bedruckt
Grembiuli con stampe

1 u.m.vta
40 box

MOD.21602130

Schürzenkittel, Einheitsgröße für alle. Schürzenkittel Größe A.
Grembiule, taglia unica, regolabile secondo le esigenze. Grembiule taglia A.



MOD. 21902326

Aufdruck Gesicht
Stampa con viso

REF.07140



MOD. 21802219

Herzen Vielfalt
Multi-cuori

REF.07144



MOD. 21902325

Comic
Comic

REF.07141

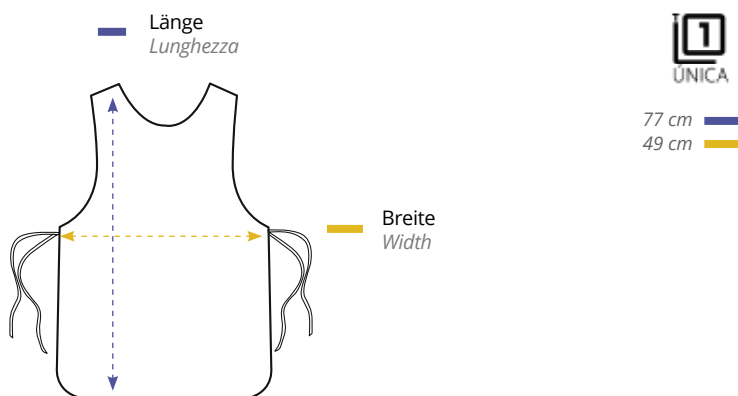

Schürzenkittel bedruckt
Grembiuli con stampe

MOD.21602130

Schürzenkittel, Einheitsgröße für alle. Schürzenkittel Größe A.
Grembiule, taglia unica, regolabile secondo le esigenze. Grembiule taglia A.

MOD. 21802218

Strähnen
Meches

REF.07143



MOD. 21802233

Gefärbtes Haar
Capelli colorati

REF.07142



MOD. 21802217

Nagellack
Smalto per unghie

REF.07148

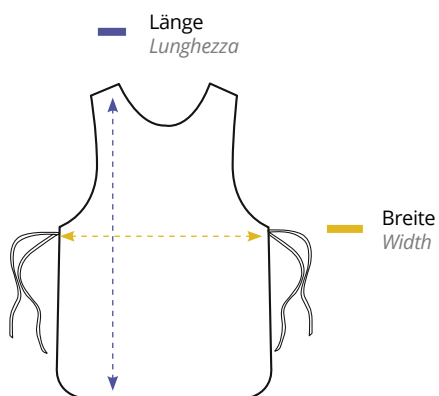
77 cm
49 cm

Schürzenkittel Stretch aus 100% Polyester
Grembiule elasticizzato 100% poliestere

1 u.m.vta 40 box

MOD. 21602124

Schürzenkittel Stretch aus 100 % Polyester mit Rückenschlaufen und großen, bequemen Vordertaschen. Rosa pinkfarbener Rand.

Grembiule 100% poliestere elasticizzato, regolabile con fiocco e dotata di ampie e comode tasche frontali.



Länge
Lunghezza

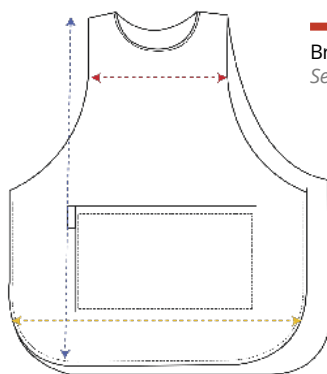

Brustumfang
Seno



35/36 cm
50/51 cm
77/78 cm

REF.06554/58

Hüftumfang
Fianchi

1 u.m.vta 40 box

MOD. 21602124

100% Polyester
100% poliestere



Länge
Lunghezza

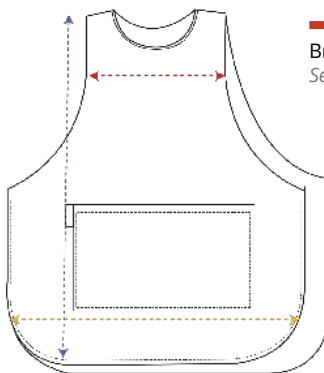

Brustumfang
Seno



35/36 cm
50/51 cm
77/78 cm

REF.06554/50

Hüftumfang
Fianchi

Transparente Schürze/schwarz
Grembiule trasparente/nero1 u.m.vta
40 box

MOD. 31306075

Schürzenkittel Stretch aus 100 % Polyester mit Rückenschlaufen und großen.

Grembiule 100% poliestere elasticizzato, regolabile sul dietro con fiocco e dotata di ampie tasche67/68 cm
79/180 cm

REF.06555

Hüfte
FianchiLänge
Lunghezza**Schürzenkittel mit Mao-Kragen**
Camice con colletto coreano1 u.m.vta
40 box

MOD.21602130

Schürzenkittel mit Mao-Kragen mit Metall-Druckknöpfen, Mini-Ärmeln und Front mit Seitentaschen. Er hat Bänder, die über den Rücken verlaufen und in der Taille gebunden werden.

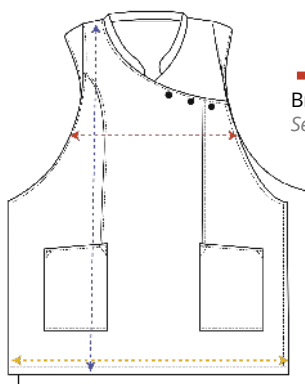
Camice con colletto alla coreana con bottoni in metallo, maniche ad aletta, e bottoni e tasche frontali. È regolabile con fasce che attraversano la schiena e annodate in vita.Länge
LunghezzaBrustumfang
SenoHüftumfang
Fianchi100% Polyester
100% poliestere

REF.06309/50

36/37 cm
59/60 cm
75/76 cm

Stretch Kittelschürze aus 100% Polyester
Grembiule elasticizzato 100% poliestere



Stretch Kittel aus 100 % Polyester mit nach hinten passender Schleife und großen, bequemen Vordertaschen
 Stola 100% poliestere elasticizzata regolata dietro con nastro e dotata di Grande e comode tasche frontali



MOD. 21304601

REF.06553/50

MOD. 21304601

REF.06553/58

MOD. 21304601

REF.06553/63

MOD. 21304601

REF.06553/68

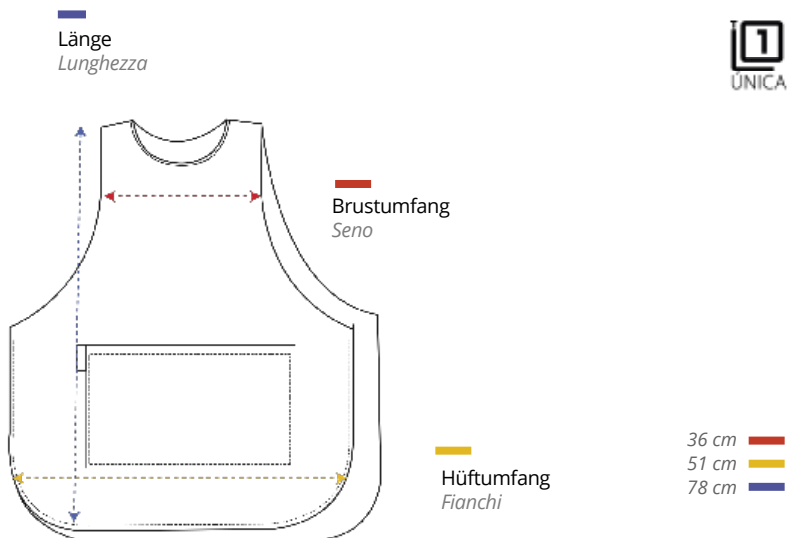

Emoticons Schürzenkittel
Grembiule emoticon

1 u.m.vta 40 box

MOD. 21602143

Enger Kittelmit Rundhalsausschnitt. Einfaches Vorderteil mit bedruckter Trenntasche in der Mitte, abgerundetem Saum und Taillenanpassung mit Bändern, die über den Rücken laufen und in der Taille geknotet werden. 100% Polyester.

Grembiule aderente con scollo tondo. Parte frontale superiore in tinta unita con tasca divisoria con stampa centrale, orli stondati e regolazione del girovita con fasce che passano dalla schiena e si allacciano in vita. 100% poliester.



36 cm
51 cm
78 cm

REF.06303/50



Länge
Lunghezza

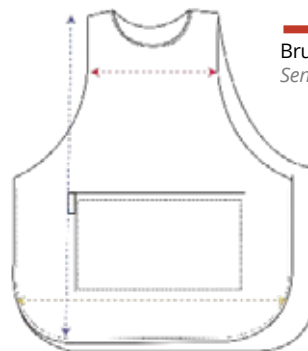

Brustumfang
Seno

Hüftumfang
Fianchi

Antistatisches KIMONO
KIMONO antistatico

1 u.m.vta 40 box

MOD. 21300013

Gekreuzter Kimono mit Gürtel und 3/4-Arm mit Minitasche am Ärmel. Leicht zu bügeln. Verbleichschutz. 100% marokkanischer Polyester.

Kimono con manica 3/4, cintura e mini tasca sulla manica. Facile da stirare. Non scolora. 100% poliester simipelle.



123 cm
123 cm
106 cm

REF.06302/50



Länge
Lunghezza

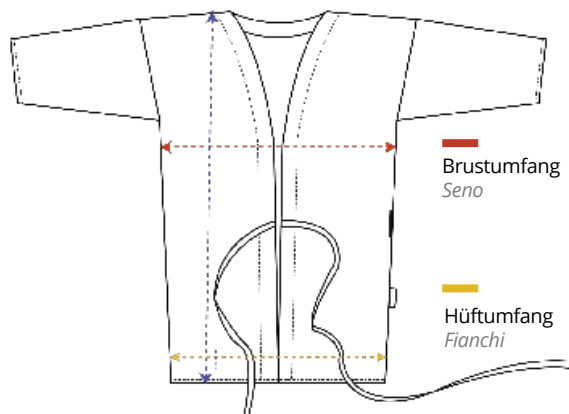

Brustumfang
Seno

Hüftumfang
Fianchi

Damen-Hosen
Pantaloni da donna

1 u.m.vta
40 box

MOD. 41300011N

» Hose mit mittlerer Taille, hinten
Elastikband mit 3 Schnüren
» 100% Polyester

» Pantaloni a vita media, elastico
posteriore con 3 lacci
» 100% poliestere

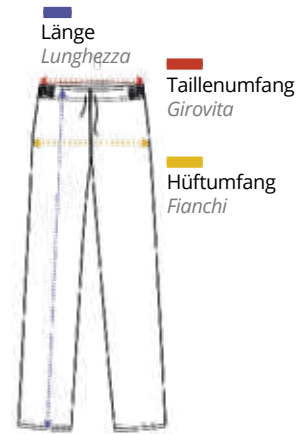

S

92-96 cm
92-96 cm
99-101 cm

REF.06312/50/1

M

98-102 cm
96-100 cm
101-103 cm

REF.06312/50/2

L

106-110 cm
106-110 cm
102-104 cm

REF.06312/50/3

XL

112-116 cm
114-118 cm
105-107 cm

REF.06312/50/4

Damen-Hosen
Pantaloni da donna

1 u.m.vta
40 box

MOD. 41300011B

» 67% Polyester
» 33% Baumwolle

» 67% poliestere
» 33% cotone

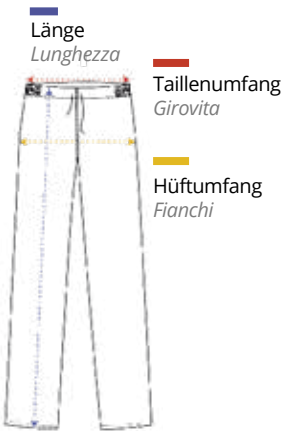

S

92-96 cm
92-96 cm
99-101 cm

REF.06312/58/1

M

98-102 cm
96-100 cm
101-103 cm

REF.06312/58/2

L

106-110 cm
106-110 cm
102-104 cm

REF.06312/58/3

XL

112-116 cm
114-118 cm
105-107 cm

REF.06312/58/4

Damen-Hosen

Pantaloni da donna



MOD. 41300901

Bi-elastische Hose, niedrige Taille, 2 Seitentaschen. Enganliegend.
 » 95% Polyester
 » 5% Bi-Elastic

Pantaloni doppio elastico, vita bassa, 2 tasche laterali. Aderenti al corpo.
 » 95% poliestere
 » 5% Bi-Elastic

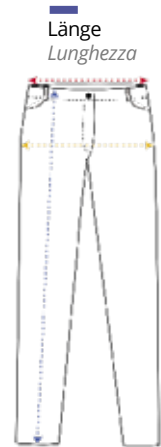

Länge
Lunghezza

Taillenumfang
Girovita

Hüftumfang
Fianchi

36	38	40	42	44
74-78 cm	78-82 cm	82-86 cm	88-92 cm	92-96 cm
90-94 cm	94-98 cm	96-100 cm	98-102 cm	100-104 cm
100-102 cm	100-102 cm	101-103 cm	103-105 cm	105-107 cm
REF. 06311/50/1	REF. 06311/50/2	REF. 06311/50/3	REF. 06311/50/4	REF. 06311/50/5

Unisex-Hosen

Pantaloni unisex



MOD. 41300904

Hose aus 100% Polyester fein mit 3 Taschen. In der Taille mit einem Kordelzug verstellbar. Leicht zu bügeln. Verbleichschutz und antistatisch.

Pantaloni 100% poliestere fine con 3 tasche. Vita regolabile con laccio. Facile da stirare. Antistatico e non scolora.



Länge
Lunghezza

Taillenumfang
Girovita

Hüftumfang
Fianchi

S	M	L	XL
92-96 cm	98-102 cm	106-110 cm	112-116 cm
92-96 cm	96-100 cm	106-110 cm	114-118 cm
99-101 cm	101-103 cm	102-104 cm	105-107 cm
REF.06356/1	REF.06356/2	REF.06356/3	REF.06356/4

Haarkosmetik

COSMETICI
PER CAPELLI

*Shampoos, masken, färbemittel,
Bleichmittel, oxidationsmittel...*

*Shampoo, balsamo, tinta per capelli,
Decoloranti, creme ossidanti...*



Bright Colour Farbstoffe von Tassel

Colore Bright Colour di Tassel



Oxidations-Cremefärbemittel, angereichert mit Arganöl, Keratin und pflanzlichen Wachsen, die die Farbe fixieren und gleichzeitig dem Haar Glanz und Schutz verleihen. Weich strukturierte Creme. Aufgrund ihrer Zusammensetzung behandelt es das Haar, pflegt es, schützt es und bildet eine Schutzbarriere, um die Haarstruktur nicht zu schädigen. Farbbeständigkeit und maximale Abdeckung. Große Auswahl an Farben, die die Marktbedürfnisse abdecken.

Colore in crema arricchito con olio di argan, cheratina e cere vegetali che aiutano a fissare il colore fornendo lucentezza e protezione ai capelli. Crema dalla texture delicata. Grazie alla sua composizione, si prende cura dei capelli proteggendoli e formando una barriera protettiva per non danneggiare la struttura capillare. Colore duraturo e massima copertura. Ampia gamma di colori che soddisfano le esigenze del mercato.



**100%ige Abdeckung und Haltbarkeit Verleiht
Glanz und Schutz
95 intensive Farben**

**Copertura e durata al 100%
Dona lucentezza e protezione
95 colori intensi**

- » Hergestellt aus Arganöl, Keratin und pflanzlichen Wachsen, die zur Fixierung der Farbe beitragen, dem Haar sowohl Glanz als auch Schutz verleihen
- » Sortierte Farben mindestens 3 Einheiten pro
- » Farbe von 36 Einheiten

- » *Composizione a base di olio di argan, cheratina e cere vegetali che aiutano a fissare il colore, donando lucentezza e protezione ai capelli*
- » *Colori assortiti. Minimo 3 unità per colore*
- » *Scatole complete: 36 unità*

**Keratin
Pflanzenwaxse
Arganöl**

**Cheratina Cere
Vegetali
Olio di Argan**

11.5

New

nordic BRIGHT COLOUR

Ref. 0646E

**10N** ▼

RUBIO SUPER CLARO
SUPER LIGHT BLONDE
BLOND SUPER CLAIR
LENTHNER BLONDEN
LOURO SUPER CLARO
الشعر فاتح جداً

Ref. 0646D

**10.3N** ▼

RUBIO SUPER CLARO DORADO
SUPER LIGHT GOLDEN BLONDE
BLOND SUPER CLAIR DORÉ
LOURO SUPER CLARO DOURADO
ЦВЕТ ПЕРЛОВОГО ЗОЛОТОГО ШОКОЛА
الشعر ذهبي فاتح جداً

Ref. 0646F

**10.31N** ▼

RUBIO SUPER CLARO DORADO CINZA
SUPER LIGHT GOLDEN ASH BLONDE
BLOND SUPER CLAIR DORÉ CENDRE
LOURO SUPER CLARO DOURADO CINZA
ЦВЕТ ПЕРЛОВАЯ ПИЛЬШАНО-ЗОЛОТОГО ШОКОЛА
الشعر ذهبي فاتح جداً مع رمادي

Ref. 0646H

**10.32N** ▼

RUBIO SUPER CLARO BEIGE
SUPER LIGHT BEIGE BLONDE
BLOND SUPER CLAIR BEIGE
LOURO SUPER CLARO BEGE
ЦВЕТ ПЕРЛОВАЯ БЕЖЕВАЯ ШОКОЛА
الشعر بيج فاتح جداً

Ref. 0646G

**9.13N** ▼

RUBIO MUY CLARO CINZA
VERY LIGHT GOLDEN ASH BLONDE
BLOND TRÈS CLAIR CENDRE DORÉ
LOURO MUITO CLARO CINZA DOURADO
ЦВЕТ ПЕРЛОВАЯ ПИЛЬШАНО-ЗОЛОТОГО ШОКОЛА
الشعر ذهبي فاتح جداً مع رمادي

Ref. 0646I

**9.21N** ▼

RUBIO MUY CLARO BEIGE CINZA
VERY LIGHT BEIGE ASH BLONDE
BLOND TRÈS CLAIR BEIGE CENDRE
LOURO MUITO CLARO BEGE CINZA
ЦВЕТ ПЕРЛОВАЯ БЕЖЕВАЯ ПИЛЬШАНО
الشعر رمادي فاتح جداً مع بيج

Ref. 0646A

**9.23N** ▼

RUBIO MUY CLARO BEIGE DORADO
VERY LIGHT GOLDEN BEIGE BLONDE
BLOND TRÈS CLAIR BEIGE DORÉ
LOURO MUITO CLARO BEGE DOURADO
ЦВЕТ ПЕРЛОВАЯ ЗОЛОТОГО БЕЖЕВАЯ ШОКОЛА
الشعر ذهبي فاتح جداً مع بيج

Ref. 0646J

**8.21N** ▼

RUBIO CLARO BEIGE CINZA
LIGHT BEIGE ASH BLONDE
BLOND CLAIR BEIGE CENDRE
LOURO CLARO BEGE CINZA
ЦВЕТ ПЕРЛОВАЯ БЕЖЕВАЯ ШОКОЛА
الشعر رمادي فاتح مع بيج

Ref. 0646K

**8.23N** ▼

RUBIO CLARO BEIGE DORADO
LIGHT GOLDEN BEIGE BLONDE
BLOND CLAIR BEIGE DORÉ
LOURO CLARO BEGE DOURADO
ЦВЕТ ПЕРЛОВАЯ ЗОЛОТОГО БЕЖЕВАЯ ШОКОЛА
الشعر ذهبي فاتح مع بيج

11.3

SUPER ACLARANTES

SUPER LIGHTENERS · SUPER ÉCLAIRCISANTS · СИЛЬНЫЕ ОСВЕТЛИТЕЛИ · SUPERACLARADORES · ألوان فاتحة مختلفة

Ref. 0394E

**11.21** ▼

RUBIO EXTRA CLARO PERLA CINZA
PEARL ASH EXTRA LIGHT BLONDE
BLOND EXTRA CLAIR PERLE CENDRE
ПЕРЛОВОШАЯ ШОКОЛАВА С
ПЕРЛОВОГО-ЗЕЛЕНОВАТОГО ОТТОНОВ
LOURO EXTRA CLARO PEROLA CINZA
الشعر فاتح جداً لؤلؤي رمادي

Ref. 0395

**11.00** ▼

RUBIO EXTRA CLARO NATURAL
NATURAL EXTRA LIGHT BLONDE
BLOND EXTRA CLAIR NATUREL
ПЕРЛОВОШАЯ ЗЕЛЕНОВАТОГО С
НАТУРАЛЬНЫМ ОТТОНОВ
LOURO NATURAL EXTRA CLARO
الشعر فاتح جداً طبيعي

Ref. 0495

**12** ▼

SUPERACLARANTE
RUBIO NATURAL
BLOND NATURAL SUPERLIGHTENING
BLOND NATUEL SUPER ÉCLAIRCISANT
ЦВЕТ ПЕРЛОВАЯ НАТУРАЛЬНАЯ ШОКОЛА
LOURO SUPER ACLARADOR NATURAL
الشعر طبيعي مع بيج فاتح

Ref. 0496

**12.1** ▼

SUPERACLARANTE RUBIO CINZA
SUPERLIGHTENING ASH BLONDE
BLOND CENDRE SUPER ÉCLAIRCISANT
ЦВЕТ ПЕРЛОВАЯ ПИЛЬШАНО ШОКОЛА
LOURO SUPER ACLARADOR CINZA
الشعر رمادي مع مختلف

Ref. 0497

**12.96** ▼

RUBIO SUPERACLARANTE CINZA VIOLETA
SUPERLIGHTENING VIOLET ASH BLONDE
BLOND VIOLET CENDRE SUPER
ÉCLAIRCISANT
ЦВЕТ ПЕРЛОВАЯ ПИЛЬШАНО ШОКОЛА
ШАКОЛАВА
LOURO SUPER ACLARADOR PLATINO VIOLETA
فاتح جداً مع رمادي مع
اللون البنفسجي

Ref. 0820

**PLATA** ▼

PLATA SUPERACLARANTE
SUPER LIGHTENING SEVERE
ARGENT SUPER ÉCLAIRCISANT
ОСВЕТЛИТЕЛЬ СУПЕРПЕРЛОВАЯ
PLATA SUPER ACLARADOR
الشعر فاتح جداً

11.4

TONOS PASTEL · PASTEL TONES · TONS PASTEL · ПАСТЕЛЬНЫЕ ОТТОНКИ · ألوان ناعمة

Ref. 0714D

**PT 0.8** ▼

ROSA PASTEL
PINK PASTEL
ROSE PASTEL
РОЗОВАЯ ПИЛЬШАНО
ناعم لؤلؤي

Ref. 0715D

**PT 0.7** ▼

LILA PASTEL
LILAC PASTEL
VIOLET PASTEL
ЛИЛОВАЯ ПИЛЬШАНО
ناعم لؤلؤي

Ref. 0715I

**PT 0.4** ▼

MELCOTON
PEACH ROSE
PEACH
РОЗОВО-ПЕРЛОВАЯ ШОКОЛА
ناعم لؤلؤي

Ref. 0715J

**PT 0.1** ▼

GRIS METÁLICO
METALIC GREY
GRIS METÁLICO
СЕРЫЙ МЕТАЛЛИК
ناعم لؤلؤي

BASES NATURALES

NATURAL BASE COLOURS · BASES NATURELLES · НАТУРАЛЬНЫЕ БАЗОВЫЕ · BASES NATURAIS · اَسْسِن طَبِيعِيَّة

Ref. 03954



10 ▼

RUBIO SUPER CLARO
SUPER LIGHT BLONDE
BLOND SUPER CLAIR
PLATYNORMA FLEISCHER
LOURO SUPER CLARO
اشقر فاتح فاتح

Ref. 03955



9 ▼

RUBIO MUY CLARO
VERY LIGHT BLONDE
BLOND TRÈS CLAIR
OPHÈE CÉSTIM FLEISCHER
LOURO MUITO CLARO
اشقر فاتح جدا

Ref. 03956



8 ▼

RUBIO CLARO
LIGHT BLONDE
BLOND MIEUX
CÉSTIM FLEISCHER
LOURO CLARO
اشقر فاتح

Ref. 03957



7 ▼

RUBIO MEDIO
MEDIUM BLONDE
BLOND FONCE
CÉSTIM FLEISCHER
LOURO MEDIO
اشقر متوسط

Ref. 03958



6 ▼

RUBIO OSCURO
DARK BLONDE
BLOND FONCÉ
TEHMAR FLEISCHER
LOURO ESCURO
اشقر داكن

Ref. 03959



5 ▼

CASTAÑO CLARO
LIGHT CHESTNUT
CHÂTAIGN CLAIR
CÉSTIM FLEISCHER
CASTAÑO CLARO
كستنائي فاتح

Ref. 03960



4 ▼

CASTAÑO MEDIO
MEDIUM CHESTNUT
CHÂTAIGN MOYEN
CÉSTIM FLEISCHER
CASTAÑO MEDIO
كستنائي متوسط

Ref. 03961



3 ▼

CASTAÑO OSCURO
DARK CHESTNUT
CHÂTAIGN FONCÉ
TEHMAR FLEISCHER
CASTAÑO OSCURO
كستنائي داكن

Ref. 03962



2 ▼

MORE BRUN
BRUN
KOPPELBERG
MORE BRUN
أسمر

Ref. 03963



1 ▼

NEIRO
BLACK
NOIR
CHÊNAUX
PRETO
أسود

BASES FRIAS

COOL BASE COLOURS · BASES FROIDES · ХОЛОДНЫЕ БАЗОВЫЕ · BASES FRIAS · اَسْسِن بَارِدَة

Ref. 03964



9.01 ▼

RUBIO MUY CLARO FRO
COOL VERY LIGHT BLONDE
BLOND TRÈS CLAIR FROID
CÉSTIM FLEISCHER
LOURO MUITO CLARO FRO
اشقر فاتح جدا بارد

Ref. 03965



8.01 ▼

RUBIO CLARO FRO
COOL LIGHT BLONDE
BLOND CLAIR FROID
CÉSTIM FLEISCHER
LOURO CLARO FRO
اشقر فاتح بارد

Ref. 03966



7.01 ▼

RUBIO MEDIO FRO
COOL MEDIUM BLONDE
BLOND MOYEN FROID
CÉSTIM FLEISCHER
LOURO CLARO FRO
اشقر متوسط بارد

Ref. 03967



6.01 ▼

RUBIO OSCURO FRO
COOL DARK BLONDE
BLOND FONCÉ FROID
TEHMAR FLEISCHER
LOURO ESCURO FRO
اشقر داكن بارد

VIOLETES

VIOLETS · ФИОЛЕТОВЫЕ · VIOLETAS · الرُّبَانِيَّة

Ref. 03968



7.88 ▼

FUSILIA ARDENTE
FUCHSIA
ROUGE ARDENT
CÉSTIM FLEISCHER
ROUX ARDENTE
أز هوالي حاد

Ref. 03969



4.20 ▼

CASTAÑO MEDIO VIOLETA
MEDIUM VIOLET CHESTNUT
CHÂTAIGN MOYEN VIOLET
CÉSTIM FLEISCHER
ФИОЛЕТОВЫЙ ОТТЕНОК
CASTAÑO MEDIO VIOLETA
كستنائي متوسط بنمسي

Ref. 03970



1.20 ▼

NEGRO MORA
VIOLET BLACK
NOIR VIOLET
CÉSTIM FLEISCHER
PRETO VIOLETA
أسود بنمسي

CAOBAS · DARK AUBURN · ACAJOU

МАХАГОНОВЫЕ · ACAJOU · ماهو غامبي

Ref. 03967



6.54 ▼

RUBIO OSCURO CAOBA CORRIDO
DARK AUBURN DARK BLONDE
BLOND FONCÉ ACAJOU CUNVE
TEHMAR FLEISCHER
MEDIO MAHAGONOVYIM OTTONOK
LOURO ESCURO ACAJOU ACORRIDO
اشقر داكن ماهو غامبي نجاسي

Ref. 03968



5.5 ▼

CASTAÑO CLARO CAOBA
LIGHT AUBURN
CHÂTAIGN CLAIR ACAJOU
CÉSTIM FLEISCHER
МАХАГОНОВЫЙ ОТТЕНОК
CASTAÑO CLARO ACAJOU
كستنائي فاتح ماهو غامبي

DORADOS
GOLDEN · DORÉS · ЗОЛОТЫЕ · DOURADOS · ذهنية

Ref. 03972



8.34 ▼

RUBIO CLARO DOURADO COBRE
GOLDEN COPPER LIGHT BLONDE
BLOND CLAIR DORÉ CUIVRE
СРЕДНЯЯ ЗОЛОТЫЙ С КОПРЬЮ
ЗОЛОТЫЙ СРЕДНЯЯ КОПРЬ
LOURO CLARO DOURADO ACOBRADO
ألقر فاتح ذهني نحاسي

Ref. 03977



5.3 ▼

CASTAÑO CLARO DOURADO
LIGHT GOLDEN CHESTNUT
CHÂTAIGN CLAIR DORÉ
СРЕДНЯЯ ЗОЛОТЫЙ С ЗОЛОТЫМ
ОТТЕКОМ
CASTAÑO CLARO DOURADO
كستنائي فاتح ذهني

Ref. 03973



9.3 ▼

RUBIO MUY CLARO DOURADO
VERY LIGHT GOLDEN BLONDE
BLOND TRÈS CLAIR DORÉ
ОЧЕНЬ СРЕДНЯЯ ЗОЛОТЫЙ С
ЗОЛОТЫМ ОТТЕКОМ
LOURO MUITO CLARO DOURADO
ألقر فاتح جدا ذهني

Ref. 04003



5.35 ▼

CASTAÑO CLARO DOURADO CACA
MEDIUM GOLDEN HAWGANY CHESTNUT
CHÂTAIGN CLAIR DORÉ ACAJOU
СРЕДНЯЯ ЗОЛОТЫЙ С КОКОСОВЫМ
КАЛЕНАКОМ
CASTAÑO CLARO DOURADO ACAJÚ
كستنائي فاتح مع حمر البرتقال

Ref. 03974



8.3 ▼

RUBIO CLARO DOURADO
GOLDEN LIGHT BLONDE
BLOND CLAIR DORÉ
СРЕДНЯЯ ЗОЛОТЫЙ С
СРЕДНЕЙ ТОН ОТТЕКОМ
LOURO CLARO DOURADO
ألقر فاتح ذهني

Ref. 04009



7.31 ▼

RUBIO MEDIO DOURADO FRO
COOL MEDIUM GOLDEN BLONDE
BLOND MOYEN DORÉ FROID
СРЕДНЯЯ ЗОЛОТЫЙ С ЗОЛОТЫМ
ТЕПЛОМ
LOURO MEDIO DOURADO FRO
ألقر متوسط ذهني بارد

Ref. 03975



7.3 ▼

RUBIO MEDIO DOURADO
MEDIUM GOLDEN BLONDE
BLOND MOYEN DORÉ
СРЕДНЯЯ ЗОЛОТЫЙ С ЗОЛОТЫМ
ОТТЕКОМ
LOURO MEDIO DOURADO
ألقر متوسط ذهني

Ref. 04130



8.31 ▼

RUBIO CLARO DOURADO CINZA
LIGHT GOLDEN ASH BLONDE
BLOND CLAIR DORÉ CENDRE
СРЕДНЯЯ ЗОЛОТЫЙ С
СРЕДНЕЙ ТОН
LOURO CLARO DOURADO CINZA
ألقر فاتح ذهني رمادي

Ref. 03976



6.3 ▼

RUBIO CLARO DOURADO
DARK GOLDEN BLONDE
BLOND CLAIR DORÉ
СРЕДНЯЯ ЗОЛОТЫЙ С ЗОЛОТЫМ
ОТТЕКОМ
LOURO CLARO DOURADO
ألقر فاتح ذهني

Ref. 04004



7.35 ▼

RUBIO MEDIO DOURADO CACA
MEDIUM GOLDEN HAWGANY BLONDE
BLOND MOYEN DORÉ ACAJOU
СРЕДНЯЯ ЗОЛОТЫЙ С КОКОСОВЫМ
КАЛЕНАКОМ
LOURO MEDIO DOURADO ACAJÚ
ألقر متوسط ذهني حمر البرتقال

CENIZAS
ASH · CENDRES · ПЕПЕЛЬНЫЕ · CINZAS · رمادية

Ref. 03958



8.1 ▼

RUBIO CLARO CINZA
LIGHT ASH BLONDE
BLOND CLAIR CENDRE
СРЕДНЯЯ ЗОЛОТЫЙ С
СРЕДНЕЙ ТОН ОТТЕКОМ
LOURO CLARO CINZA
ألقر فاتح رمادي

Ref. 03959



7.1 ▼

RUBIO MEDIO CINZA
MEDIUM ASH BLONDE
BLOND MOYEN CENDRE
СРЕДНЯЯ ЗОЛОТЫЙ С
СРЕДНЕЙ ТОН ОТТЕКОМ
LOURO MEDIO CINZA
ألقر متوسط رمادي

Ref. 03970



6.1 ▼

RUBIO OSCURO CINZA
DARK ASH BLONDE
BLOND FONCÉ CENDRE
СРЕДНЯЯ ЗОЛОТЫЙ С
СРЕДНЕЙ ТОН ОТТЕКОМ
LOURO OSCURO CINZA
ألقر داكن رمادي

Ref. 03971



5.1 ▼

CASTAÑO CLARO CINZA
LIGHT ASH CHESTNUT
CHÂTAIGN CLAIR CENDRE
СРЕДНЯЯ ЗОЛОТЫЙ С
СРЕДНЕЙ ТОН ОТТЕКОМ
CASTAÑO CLARO CINZA
كستنائي فاتح رمادي

Ref. 04038



1.1 ▼

NEIRO AZULADO
BLUE BLACK
NOIR BLEUÉ
NEIRO AZULADO
أزرق

Ref. 04033



10.1 ▼

RUBIO PLATINO CINZA
ASH PLATINUM BLONDE
BLOND PLATINE CENDRE
СРЕДНЯЯ ЗОЛОТЫЙ С
LOURO PLATINO CINZA
ألقر بلاتيني رمادي

Ref. 04039



PLATA ▼

PLATA INTENSO CINZA CINZA
ASH INTENSE SILVER
CENDRE ARGENT INTENSE
СРЕДНЯЯ ЗОЛОТЫЙ С
PILATA INTENSO CINZA
ألقر مركز مثل قزماني

BEIGE
BEЖЕБНЫЕ · BEGE · بيج

Ref. 03978



9.32 ▼

RUBIO MUY CLARO BEGE
VERY LIGHT BEIGE BLONDE
BLOND TRÈS CLAIR BEGE
ОЧЕНЬ СРЕДНЯЯ БИЖЕ
СРЕДНЯЯ БИЖЕ
LOURO MUITO CLARO BEGE
ألقر فاتح جدا بيج

Ref. 03979



8.32 ▼

RUBIO CLARO BEGE
LIGHT BEIGE BLONDE
BLOND CLAIR BEGE
СРЕДНЯЯ БИЖЕ
СРЕДНЯЯ БИЖЕ
LOURO CLARO BEGE
ألقر فاتح بيج

Ref. 03980



7.32 ▼

RUBIO MEDIO BEGE
MEDIUM BEIGE BLONDE
BLOND MOYEN BEGE
СРЕДНЯЯ БИЖЕ
СРЕДНЯЯ БИЖЕ
LOURO MEDIO BEGE
ألقر متوسط بيج

1+1.5

MARRONES

BROWN · MARRONS · КОПЧЕНЫЕ · MARRONS · ألوان بنية كلاسيكية

Ref. 04818



8.77 ▼

FIBRO CLARO CHOCOLATE
LIGHT CHOCOLATE BLONDE
BLOND CLAIR CHOCOLAT
BLOND CIEITO KOPCHENYEH
LOURO CLARO CHOCOLATE
ألوان فاتح شوكولاته

Ref. 03881



7.77 ▼

FIBRO MEDIO CHOCOLATE
MEDIUM CHOCOLATE BLONDE
BLOND MOYEN CHOCOLAT
CIELOHRYB KOPCHENYEH C
BLOND MOYEN OTTENSOM
LOURO MEDIO CHOCOLATE
ألوان متوسط شوكولاته

Ref. 04820



6.77 ▼

FIBRO OSCURO MARRON MEDIO
MEDIUM BROWN DARK BLONDE
BLOND FONCE MARRON MOYEN
TEMNABR SZONAL CIELOHRYB
KOPCHENYEH
LOURO ESCURO CASTANHO MEDIO
ألوان وادم كستنائي متوسط

Ref. 03882



5.77 ▼

MARRON CHOCOLATE
CHOCOLATE BROWN
MARRON CHOCOLAT
KOPCHENYEH C IBERKATAZSAB OTTENSOM
MARRON CHOCOLATE
ألوان شوكولاته

Ref. 04807



4.77 ▼

CASTANO MEDIO CHOCOLATE
MEDIUM CHOCOLATE CHESTNUT
CHATAIN MOYEN CHOCOLAT
CIELOHRYB KOPCHENYEH IBERKATAZSAB
CASTANHO MEDIO CHOCOLATE
كستنائي متوسط شوكولاته

Ref. 04817



8.7 ▼

FIBRO CLARO MARRON
LIGHT BROWN BLONDE
BLOND CLAIR MARRON
BLOND CIEITO KOPCHENYEH
LOURO CLARO CASTANHO
ألوان فاتح كستنائي

Ref. 04815



7.7 ▼

FIBRO MEDIO MARRON
MEDIUM BROWN BLONDE
BLOND MOYEN MARRON
CIELOHRYB KOPCHENYEH
LOURO MEDIO CASTANHO
ألوان متوسط كستنائي

Ref. 04811



6.7 ▼

FIBRO OSCURO MARRON
DARK BROWN BLONDE
BLOND FONCE MARRON
BLOND TEMNABR KOPCHENYEH
LOURO ESCURO CASTANHO
ألوان غامق كستنائي

Ref. 04812



5.7 ▼

CASTANO CLARO MARRON
LIGHT BROWN CHESTNUT
CHATAIN CLAIR MARRON
CIEITO CHATAIN
CASTANHO CLARO CASTANHO
كستنائي فاتح كستنائي

Ref. 04816



7.71 ▼

FIBRO MEDIO MARRON FRO
COOL MEDIUM BROWN BLONDE
BLOND MOYEN MARRON FRO
BLOND KOPCHENYEH FRO
LOURO MEDIO CASTANHO FRO
ألوان فاتح كستنائي

Ref. 04814



6.71 ▼

FIBRO OSCURO MARRON FRO
COOL DARK BROWN BLONDE
BLOND FONCE MARRON FRO
TEMNABR SZONAL KOPCHENYEH
LOURO ESCURO CASTANHO FRO
ألوان غامق كستنائي

Ref. 03903



7.73 ▼

FIBRO MEDIO AVELLANA
MEDIUM HAZELNUT BLONDE
BLOND MOYEN NOISETTE
CIELOHRYB KOPCHENYEH C
OTTENSOM
LOURO MEDIO AVELA
ألوان متوسط بندق

Ref. 03904



6.73 ▼

MARRON AVELLANA
HAZELNUT BROWN
MARRON NOISETTE
KOPCHENYEH C OTTENSOM
OTTENSOM
ألوان بندقCOLOR
PROFESIONAL
PROFESSIONAL COLOURACEITE
DE ARGÁN
ARGAN OIL

1+1.5

MATIZADORES

TONERS · NUANCEURS · OTTENSOMERN · مكثبات

Ref. 06488

AMARELO
YELLOW
JAUNE
KERTAM
AMARELO
الأصفر

Ref. 06482

ROJO
RED
ROUGE
KOPCHENYEH
VERMELHO
الأحمر

Ref. 06485

VIOLETA
VIOLET
VIOLET
BIORETZSAB
VIOLETA
البنفسجي

Ref. 06483

AZUL
BLUE
BLEU
CERMA
AZUL
أزرق

Ref. 06486

VERDE
GREEN
VERT
SEVERAL
VERDE
الأخضر

Ref. 06481

00 ▼
BASE BLANCA BEZCLA
SHATE NATURE BASE
BASI MELANGE BLANC BASE
SEKAR CHOKRA
SHANKA
الأساس الأبيض

1+1.3 ROJOS
RÉDS · ROUGES · КРАСНЫЕ · VERMELHOS · أحمر



Ref. 0434
5.6 ▼
CASTAÑO CLARO ROJO
LIGHT RED CHESTNUT
CHÂTAIN CLAIR ROUGE
CASTAÑO CLARO VERMELHO
كشاماني فاتح أحمر

Ref. 0431
6.6 ▼
RUBIO OSCURO ROJO
DARK RED BLONDE
BLOND FONCÉ ROUGE
TEMNO-KOPNÝ ROZOVÝ
LOURO ESCURO VERMELHO
أشقر داكن أحمر

Ref. 0380
6.64 ▼
RUBIO OSCURO ROJO COBRE
DARK COPPER RED BLONDE
BLOND FONCÉ ROUGE CUIVRE
TEMNO-KOPNÝ ROZOVÝ S OTTONOM
LOURO ESCURO VERMELHO ACORADO
أشقر داكن أحمر نحاسي

Ref. 0386
7.63 ▼
RUBIA
CHERRY RED
CERISE
NEDERBERRY
VERMELHO CEREA
كرزى

Ref. 0640
7.62 ▼
RUBIO MEDIO ROJO CEREZA
MEDIUM CHERRY BLONDE
BLOND MOYEN CERISE
LOURO MEDIO CEREJA
CEREA VERMELHO MEDIUM
أشقر متوسط كرزى



Ref. 0660
8.66 ▼
RUBIO CLARO ROJO FUEGO
LIGHT FIERY BLONDE
BLOND CLAIR FEU
CERTEAR DEȘNEU-KOPNÝ ROZOVÝ
LOURO VERMELHO CLARO FOGO
أشقر ناري فاتح

1+1.3 COBRES
COPPERS · CUIVRES · МЕДНЫЕ · ACORADOS · نحاسية



Ref. 0799
8.44 ▼
RUBIO CLARO COBRE INTENSO
INTENSE COPPER LIGHT BLONDE
BLOND CLAIR CUIVRE INTENSE
INTENSIVNO MEDNÝ CESTNÝ
SOKLA
LOURO CLARO ACORADO INTENSO
أشقر صاف نحاسي داكن

Ref. 0180
7.44 ▼
RUBIO MEDIO COBRE INTENSO
INTENSE MEDIUM COPPER BLONDE
BLOND MOYEN CUIVRE INTENSE
DREVNÝ ROZOVÝ S C. ROZ. MEDNÝM
OTTOMOM
LOURO MEDIO ACORADO INTENSO
أشقر متوسط نحاسي قوي

Ref. 0398
7.43 ▼
RUBIO MEDIO COBRE DORADO
MEDIUM GOLDEN COPPER BLONDE
BLOND MOYEN CUIVRE DORÉ
CERENNA DREVNÝ S
ZDORTAČTO MEDNÝM OTTOMOM
LOURO MEDIO ACORADO DOURADO
أشقر متوسط نحاسي ذهبي

Ref. 0391
7.4 ▼
RUBIO MEDIO COBRE
MEDIUM COPPER BLONDE
BLOND MOYEN CUIVRE
CERENNA OTTOMOM S MEDNÝM
OTTOMOM
LOURO MEDIO ACORADO
أشقر متوسط نحاسي



Ref. 0392
6.44 ▼
RUBIO OSCURO COBRE INTENSO
DARK INTENSE COPPER BLONDE
BLOND FONCÉ CUIVRE INTENSE
TEMNO-KOPNÝ S C. ROZ. MEDNÝM
OTTOMOM
LOURO ESCURO ACORADO INTENSO
أشقر داكن نحاسي قوي



Ref. 0393
6.4 ▼
RUBIO OSCURO COBRE I
DARK COPPER BLONDE
BLOND FONCÉ CUIVRE
TEMNO-KOPNÝ S C. MEDNÝM
OTTOMOM
LOURO ESCURO ACORADO
أشقر داكن نحاسي



CERAS VEGETALES
VEGETABLE WAXES



FANTASÍA
FANTASY · FANTAISIE · ФАНТАЗИЯ · FANTASIA · فانتازيا

· APLICACIÓN DIRECTA SIN EMULSION · DIRECT APPLICATION WITHOUT EMULSION
· APLICAZIONE DIRETTA SEN EMULSION · APLICAZIONE DIRETTA SEN EMULSION
· APLICAZIONE DIRETTA SEN EMULSION · APLICAZIONE DIRETTA SEN EMULSION



Ref. 0442
B.0 ▼
BLANCO
WHITE
BLANC
BIANCO
بياض

Ref. 0443
B.8 ▼
ROSA
PINK
ROSE
ROSE
روزى

Ref. 0444
B.5 ▼
CICLAMEN
CYCLAMEN
CYCLAMEN
CICLAMEN
سجور قزوينى

Ref. 0445
B.7 ▼
GRAP
GRAPE
BAGN
BIRHOFAE
UVA
عنب

Ref. 0446
B.6 ▼
AZUL
BLUE
BLEU
CAVALO
AZUL
كزى

Ref. 0447
B.3 ▼
AMARILLO
YELLOW
JAUNE
GELTR
AMARILLO
أصفر

Farbkarte mit Strähnen
*Catalogo colori, tinte per capelli, a ciocche*1
u.m.vta20
box

REF.04581/4

**Farbkarte mit gedruckten Farben**
*Catalogo colori, delle tinte per capelli*1
u.m.vta25
box

REF.EM49325



Oxidationscreme 20 vol. Crema ossidante 20 vol.

Schnelle und bequeme Trockenreinigung
Lavaggio a secco veloce e comodo

NEW



75 ml

20 vol

REF. 07160



Oxidierende Creme Crema ossidante



Dank ihrer cremigen Textur und ihrer Bestandteile aus Pflanzenextrakten und natürlichen Ölen lässt es sich leichter emulgieren und auf dem Haar verteilen, wobei es die Haarfaser viel besser schützt und das Haar weich und gepflegt bleibt.

Grazie alla sua grazie alla sua cremosita e ai suoi componenti a base di estratti vegetali e oli naturali, è più facile da miscelare e applicare sui capelli, nel pieno rispetto del cuoio capelluto e delle fibre del capello, lasciando i capelli morbidi e trattati.

» Apfel-Parfüm
» Profumo di mela

150 ml

10 vol

REF. 04336

20 vol

REF. 04209

30 vol

REF. 04210

40 vol

REF. 04211



» Apfel-Parfüm
» Profumo di mela



1L

10 vol

REF. 04337

20 vol

REF. 04067



30 vol

REF. 04068

40 vol

REF. 04069

Oxidierende Creme Crema ossidante

» Apfel-Parfüm
» Profumo di mela

1
u.m.vta

2
box

5L

10 vol

REF.04438

20 vol

REF.04439

30 vol

REF.04440

40 vol

REF.04441



Oxidationsmittel Creme Antigelbstich Crema ossidante BLUE



1
u.m.vta

6
box

Die innovative Formel von OXY BRIGHT BLUE mit ihrer leichten und fließenden Textur eignet sich besonders für blonde Flecken (ab Höhe 8) und Verfärbungen. Es eliminiert den Gelb- und Orange-Effekt und erhält gleichzeitig die natürliche Farbe ohne unerwünschte Reflexionen.

1L

L'innovativa formula di OXY BRIGHT BLUE leggera e fluida, è particolarmente indicata per tinte bionde (a partire da altezza 8) e decolorazioni. Elimina l'effetto giallo e arancio mantenendo il colore naturale senza riflessi indesiderati.



10 vol

REF. 07153

20 vol

REF. 06632

30 vol

REF. 06633

40 vol

REF. 06634

Färbekasten mit 6 Fantasiefarben
Confezioni di Tinta per capelli da 6 colori fantasia1 u.m.vta
1 box

Färbekasten mit 6 Fantasiefarben. Direkt auf das Haar auftragen. Entdecken Sie alle Kombinationen, die Sie machen können, indem Sie einfach eine unserer Farben mit Weiß mischen und so eine breite Palette von Pastelltönen erhalten. Sie können sie auch miteinander kombinieren. Um einen Hauch von Fantasie hinzuzufügen, können Sie sie auch mit Bright Colour mischen.

Confezione da 6 colori fantasia. Si applicano direttamente sui capelli. Scopri tutte le combinazioni che puoi realizzare semplicemente mescolando uno qualsiasi dei nostri colori con il bianco, ottenendo così una vasta gamma di tonalità pastello. Inoltre, puoi combinarli tra loro. Per aggiungere un tocco di fantasia, puoi anche mescolarli con le tinture Bright Color.

- » Weich und feuchtigkeitsspendend.
- » Delicato e idratante.

100 gr

REF.04611



Kein Oxidationsmittel erforderlich
Non ha bisogno di ossidante

1 u.m.vta
6 boxB-0 ○
REF. 04442B-3 ●
REF. 04447B-5 ●
REF. 04444B-6 ●
REF. 04446B-7 ●
REF. 04445B-8 ●
REF. 04443

*Nur zum Mischen und verdünnen geeignet · * Adatto solo per miscele e soluzioni

Farbstoffschutzöl

Olio protettivo per tintura



α -Bisabolol vermindert das Risiko einer Hautsensibilisierung und Reizbarkeit und schützt zusammen mit den Vitaminen E, C und Sojalecithin die Haut vor Oxidation. Es bildet eine Schutzbarriere, damit der Farbstoff die Haut nicht befleckt.

L' α -bisabololo riduce il rischio di sensibilizzazione e irritabilità della pelle e insieme alle vitamine E, C e alla lecitina di soia protegge la pelle dall'ossidazione. Crea una barriera protettiva in modo che il colorante non macchi la pelle.

120
u.m.vta

120
box

3 ml

REF.03929



100
u.m.vta

1
u.m.vta

6
box

150 ml

REF.06282



Pack farbschutz

Kit colore

- » Päckchen mit Fleckenschutzöl
- » + Einweg-Schutzhülle
- » + Handschuhe

- » Bustina d'olio protettivo
- » + mantellina monouso
- » + guanti

100
u.m.vta

100
box

3 ml

REF.03998



+



+



WILD BRIGHT Bleichpulver

Polvere Decolorante WILD BRIGHT



Grossartiger Farbenzug und gleichzeitig sanft zu dem Haar. In zwei praktischen Formaten, klein und groß, wählen Sie das Format, das Ihren Bedürfnissen am besten entspricht.

Grande capacità di rimozione del colore pur essendo delicato sui capelli. In due pratici formati, piccolo e grande, scegli quello più adatto alle tue esigenze.

50
u.m.vta50
box

25 gr

REF. 04289

» Wieder verschließbar
» Con chiusura salva-prodotto

1
u.m.vta12
box

500 gr

REF. 03922



WILD WHITE Bleichpulver

Polvere Decolorante WILD WHITE

Arganöl und Keratin

Wild White hat die gleiche Aufhellungskraft wie Wild Bright Bleichmittel, der einzige Unterschied besteht darin, dass es KEIN Ammoniak enthält und die Haarfasern dank Arganöl und Keratin schützt. Es kann auch bei Körper- und Gesichtsverfärbungen mit 10 Vol. Oxidationsmittel verwendet werden.

Olio di argan e cheratina

Wild White ha lo stesso potere schiarente del decolorante Wild Bright, l'unica differenza è che NON contiene ammoniaca e protegge la fibra capillare grazie all'olio di argan e alla cheratina. Può essere utilizzato anche per decolorazioni del corpo e del viso utilizzando 10 vol di ossidante.

Ammoniakfrei

Senza ammoniaca

50
u.m.vta50
box

25 gr

REF. 03611

» Wieder verschließbar
» Con chiusura salva-prodotto

1
u.m.vta12
box

500 gr

REF. 03921



Beutel 500g. Entfärbung deco-plex Confezione da 500g. Decolorazione deco-plex

Mehr Schutz bei Ihren Entfärbungen mit dem neuen DECO-PLEX, mit Rotalgen und Aminosäuren, die die Struktur des Haars pflegen. Kann bis zu 8-9 Töne ausspülen.

Più protezione durante le tue decolorazioni con il nuovo DECO-PLEX, con Alghe Rosse e Aminoacidi che si prendono cura della struttura del capello. Può schiarire fino a 8-9 livelli.

NEW



25 gr

REF. 07428

» Wieder verschließbar
» Con chiusura salva-prodotto

NEW



500 gr

REF.07201



Decocrema Tassel 500 gr Decocream Tassel 500 gr



Haarbleichcreme mit hoher aufhellender Wirkung. Seine innovative cremige Textur sorgt für eine bessere Pflege von Haut und Haar. Angereichert mit einem speziellen Polymer, das das Haar schützt und seinen Bruch minimiert. Es enthält Jojobaöl, das zur Verbesserung der Pflegeeigenschaften beiträgt, Glanz und Geschmeidigkeit verleiht, maximale Pflege und besseren Schutz des Haares bietet.

Crema decolorante per capelli ad alto potere schiarante. La sua innovativa texture in crema si prende più cura della pelle e dei capelli. Arricchita con uno speciale polimero che protegge i capelli minimizzandone la rottura. Contiene olio di jojoba che aiuta a migliorare le proprietà del balsamo, donando lucentezza e morbidezza, offrendo la massima cura e una migliore protezione dei capelli.

» Mit Jojobaöl
» Con olio di jojoba

500 gr

REF.06561



IONI · K TREATMENT



**Schritt für
Schritt mit
IONI-K**
*Step by step
with IONI-K*

Die Haare werden in 4 einfachen Schritten repariert. Ionen- und Keratinbehandlung, das geschädigte Haar in der Tiefe repariert und es viel glänzender und glatter aussehen lässt. Verhindert Frizz.

Capelli riparati in 4 semplici passi. Trattamento agli ioni e cheratina che ripara in profondità i capelli danneggiati, lasciando un aspetto molto più lucido e levigato. Evita l'effetto crespo.

1

**Shampoo
zum Vorglätten**
Shampoo pre-lisciante



500 ml

REF.04949

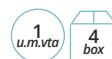

REF.04997

FORMOL FREI - Keratin-Behandlung
 Trattamento alla cheratina FORMOL FREE



Mit einem innovativen Ionensystem zusammengestellt, gibt es dem Haar Kraft und Vitalität zurück, erleichtert das Glätten und beugt Kräuseln vor. Ihr Haar wird gesünder, weicher und glänzender aussehen.

Formula con innovativo sistema di ioni che ripristina e dona forza e vitalità ai capelli, facilitando l'effetto liscio, e prevenendo l'effetto crespo. I capelli appariranno più sani, morbidi e luminosi.



2

**Glättung und
 Anti-Frizz-Behandlung**
 Trattamento
 capelli lisci e anti effetto
 crespo



500 ml

REF.04951

3

**Shampoo nach der
 Glättung**
 Shampoo
 post-lisciante



500 ml

REF.04950

4

**Versiegelnde
 Haarkur**
 Balsamo sigillante per
 capelli



400 ml

REF.04982

Dry shampoo - trockenshampoo in pulverform

Shampoo secco - shampoo secco in polvere



300 ml

REF.07130



Dry Shampoo ist ein Shampoo in Pulverform, das als Spray aufgetragen wird (BENÖTIGT KEIN WASSER). Es sorgt für ein ausgeprägteres Volumen und trägt dazu bei, dass das Haar länger sauber bleibt. Ideal für fettes Haar, absorbiert den Überschuss an Talg und schattiert den Haarschaft, wodurch es für ein saubereres und gesünderes Aussehen sorgt. Wird auch für frisch gewaschenes Haar empfohlen, um es zu wellen, ihm Volumen zu geben und das Kämmen zu erleichtern. Für jeden Haartyp.

Dry Shampoo è uno shampoo in polvere che si applica in spray (NON SERVE SCIAQUARE). Dona un volume più pronunciato. Aiuta i capelli a rimanere puliti più a lungo. Ideale per capelli grassi, assorbe il sebo in eccesso, opacizza la base del capello e dona un aspetto più pulito e sano. È consigliato anche per capelli appena lavati, per apportare texture, aggiungere volume e facilitare lo styling. Per tutti i tipi di capelli.

Hyaluronshampoo TASSEL

Hyaluronic shampoo TASSEL



Vorteile

- » Schonende Reinigung
- » Tiefen Hydratation
- » Restrukturiert das Haar

Eigenschaften

Angereichert mit Hyaluronsäure. Anti-Aging-Effekt. Sanfte Reinigung und Tiefenbefeuchtung des Haares. Restrukturiert geschädigtes und brüchiges Haar und gibt ihm seine Elastizität zurück. Versorgt das Haar mit Feuchtigkeit und macht es geschmeidig.

Benefici

- » Gentle cleaning
- » Pulizia delicata
- » Idratazione profonda
- » Ristruttura i capelli

Che cos'è?

Arricchito con acido ialuronico. Effetto antietà. Pulizia delicata e idratazione profonda dei capelli. Ristruttura i capelli danneggiati e fragili, restituendo loro elasticità. Idrata e ammorbidisce i capelli.



NEW

1 L

REF.07379



Hyaluronsäure-maske TASSEL

Hyaluronic mask TASSEL



Vorteile

- » Hydratation
- » Glättet
- » Repariert
- » Verhindert Haarbruch

Eigenschaften

Angereichert mit Hyaluronsäure. Anti-Aging-Effekt. Versorgt das Haar mit Feuchtigkeit und macht es geschmeidig. Spendet intensive Feuchtigkeit dank der Hyaluronsäure. Repariert und verhindert Bruch und Spliss. Macht das Haar weicher und flexibler.

Benefici

- » Idrata
- » Ammorbidisce
- » Ripara
- » reviene la rottura dei capelli

Che cos'è?

Arricchito con acido ialuronico. Effetto antietà. Idrata e ammorbidisce i capelli. Fornisce un'idratazione intensa grazie all'acido ialuronico. Ripara e previene rotture e doppie punte. Ammorbidisce e rende i capelli più flessibili.

NEW

1 L

REF.07380



Hyaluronic SPLASH

Hyaluronic SPLASH

Angereichert mit Hyaluronsäure, die dank ihrer Eigenschaften das Haar verbessert und ihm ein Gefühl von tiefer Feuchtigkeit, Füllung und Elastizität verleiht. Frizz vermeidet, ihm Glanz und seidige Textur verleiht. Sie vereinen Arganöl, Seidenproteine und Keratin und bilden ein ausgezeichnetes Anti-Age-Haar.

Arricchito con Acido ialuronico che, grazie alle sue proprietà, migliora i capelli donandogli una sensazione di profonda idratazione, riempimento ed elasticità, evitando l'effetto crespo, donandogli lucentezza e consistenza setosa. Unendo le proprietà dell'Olio di Argan, delle Proteine della Seta e della Cheratina, formano un ottimo Anti Age per Capelli.

NEW

1 L

REF.07438



Shampoo gegen Haarausfall**Shampoo per la prevenzione della caduta dei capelli**

- » Shampoo, das speziell zur Bekämpfung von Haarausfall erstellt wurde, da es Proteine und Bionährstoffe pflanzlichen Ursprungs kombiniert, die als Abschwellungs- und Revitalisierungsmittel wirken und so Reizungen vermeiden
- » Reinigt tief, entfernt die sich auf der Kopfhaut bildenden Öle und lässt das neue Haar sich ungehindert entwickeln
- » Das Haar ist weich, glänzend und seidig

» *Shampoo specificamente formulato per combattere la caduta dei capelli, in quanto combina proteine e bionutrienti di origine vegetale che agiscono come decongestionanti e rivitalizzanti, evitando così le irritazioni.*

- » *Deterge in profondità, eliminando i grassi che si formano sul cuoio capelluto, permettendo ai nuovi capelli di crescere senza impedimenti*
- » *Lascia i capelli morbidi, lucenti e setosi*



1 u.m.vta 12 box

1 L

REF.03566

1 u.m.vta 6 box

400 ml

REF.03553

Ampullen gegen Haarausfall**Fiale**

Die besten Nährstoffe für die Kopfhaut sind Proteine pflanzlichen Ursprungs. Sie verbessern die Aufnahme dieser und begünstigen die Sauerstoffanreicherung des Haarfollikels, wodurch der Haarausfall verringert wird. Die pflanzlichen Nährstoffe wirken zudem abschwellend und revitalisierend und vermeiden so Reizungen. Keratin erneuert und stärkt das Haar und verleiht ihm Volumen und Glanz.

I migliori nutrienti per il cuoio capelluto sono le proteine vegetali. Queste fiale ne aumentano l'assorbimento e favoriscono l'ossigenazione del follicolo pilifero, riducendo così la caduta dei capelli. I nutrienti vegetali agiscono anche come decongestionanti e rivitalizzanti, evitando così le irritazioni. La cheratina ripara e rinforza i capelli, donandogli volume e lucentezza.

PACKUNG zur Prävention von Haarausfall

- » 12 Ampullen (10 ml) zur Prävention von Haarausfall
- » + Präventionsshampoo 400 ml

PACCHETTO anticaduta

- » 12 fiale (10 ml) anticaduta
- » + shampoo prevenzione 400 ml

1 u.m.vta 6 box

10 ml

REF.03550

- » 12 Ampullen (10 ml) zur Prävention von Haarausfall

- » 12 fiale (10 ml) anticaduta

1 u.m.vta 50 box

10 ml

REF.03551



HERBAL Conditioner Creme Balsamo HERBAL

1 u.m.vta
12 box

Conditioner aus Pflanzenextrakten, die die Haarfaser erneuern, stärken und das Schuppen der Haarfaser verhindern. Diese Extrakte verleihen dem Haar Weichheit, Glanz und Leuchtkraft, was die Frisur begünstigt.

Balsamo con estratti vegetali che riparano, rinforzano e prevengono la desquamazione della fibra capillare. Questi estratti donano ai capelli morbidezza, lucentezza e luminosità, favorendo l'acconciatura.



1 L

REF.03555

NEUTRALES Shampoo Shampoo NEUTRO

1 u.m.vta
12 box

Shampoo für alle Haartypen und besonders geeignet für die tägliche oder häufige Anwendung. Es wäscht das Haar auf sanfte Weise und erhält den PH-Wert. Schützt die Kopfhaut und verleiht dem Haar Ausgeglichenheit und Gesundheit.

Shampoo per tutti i tipi di capelli e particolarmente indicato per un uso quotidiano o frequente. Lava i capelli in modo delicato e mantenendo il giusto PH. Protegge il cuoio capelluto, donando equilibrio e salute ai capelli.



1 L

REF.03556

» Häufige
Anwendung
» Uso frequente

FARBSCHUTZ Shampoo Shampoo PROTECT COLOR

Spezifisches Shampoo für gefärbtes oder coloriertes Haar. Belebt und bewahrt die Haarfarbe länger und sorgt für ein weiches, glänzendes und leuchtendes Aussehen. PH-Wert sauer

Shampoo specifico per capelli tinti o colorati. Ravviva e mantiene il colore dei capelli più a lungo, fornendo un aspetto morbido, lucido e luminoso. PH acido.

1 u.m.vta
500 box

10 ml

REF.06806



1 u.m.vta
12 box

1 L

REF.04620

1 u.m.vta
600 box

10 ml

REF.06659



1 u.m.vta
12 box

500 ml

REF.06563



NEW
1 u.m.vta
12 box

500 ml

REF.07429



Anti Gelbstich Shampoo für blondes oder weißes Haar BLUE Shampoo per capelli biondi o bianchi

Spezielles antigelbstich Shampoo, um gelbe oder orangefarbene Glanzstellen im blonden Haar zu beseitigen und ein metallischeres und natürlicheres Blond zu erreichen. Gleichzeitig ist es ideal für die Behandlung von weißem und grauem Haar, es hilft, gelbliche Töne zu reduzieren und damit die weiße Farbe des Haares zu verstärken und seine natürliche Weichheit und seinen Glanz wiederzuerlangen.

Shampoo specifico per eliminare i riflessi giallastri o arancioni dai capelli biondi, ottenendo un biondo più metallico e naturale. Allo stesso tempo, è ideale per il trattamento dei capelli bianchi e grigi, aiuta a ridurre i toni giallastri, esaltando così il colore bianco dei capelli, recuperando la loro naturale morbidezza e lucentezza.

NUTRITIVES Shampoo**Shampoo NUTRITIVO**

Shampoo mit Proteinen und Bionährstoffen, die leicht absorbiert und schnell in die Haarstruktur eingearbeitet werden. Enthält Keratin, das die Haarkutikula nährt, repariert und regeneriert und die Neigung zur Bildung von Spliss reduziert und sie vor äußeren Aggressionen schützt. Das Ergebnis ist kräftigeres Haar mit mehr Volumen und mehr Glanz.

Shampoo con proteine e bionutrienti facilmente assorbibili e rapidamente assimilabili dalla struttura del capello. Contiene cheratina che nutre, ripara e rigenera la cuticola del capello e riduce la tendenza alla formazione delle doppie punte, proteggendolo dalle aggressioni esterne. Il risultato sono capelli più forti, con più volume e più lucentezza.



1 u.m.vta 500 box

10 ml

REF.06804



1 u.m.vta 12 box

1 L

REF.03552

ARGAN Restrukturierungslinie**Linea ristrutturante ARGAN**

TASSEL kreiert die New Argan Line, die für die gründliche Behandlung der Haare konzipiert wurde. Restrukturiert die Haarfaser und verleiht ihnen ein glänzendes und regeneriertes Aussehen.

TASSEL crea la Nuova Linea Argan, pensata per il trattamento in profondità del capello. Ristruttura la fibra capillare donando un aspetto lucido e rigenerato ai capelli.

NEW



1 u.m.vta 12 box

500 ml

REF.07165

NEW



1 u.m.vta 12 box

250 ml

REF.07167

NEW



1 u.m.vta 12 box

50 ml

REF.07166

Shampoo
Shampoo

SHAMPOO Hilft bei der Regeneration von Haaren und Kopfhaut und wirkt sich positiv auf das Haarwachstum aus. Befeuchtet und mildert Frizz. Verleiht dem Haar mehr Körper und Glanz. Sprödigkeit und Bruch bekämpfen.

Aiuta nella rigenerazione dei capelli e del cuoio capelluto con un effetto positivo sulla crescita dei capelli. Idrata e ammorbidisce l'effetto crespo. Dona ai capelli più corpo e lucentezza. Combate fragilità e rotture.

Balsam
Balsamo

Intensive Ernährung von den Wurzeln bis zu den Enden, auch über die Kopfhaut. Tief konditionierend und Feuchtigkeitsspendend. Reparatur und Wiederherstellung der Haarfaser. Ideal für trockenes und strapaziertes Haar.

Nutrizione intensa dalle radici alle punte, anche attraverso il cuoio capelluto. Effetto balsamo profondo e idratazione. Riparazione della fibra capillare. Ideale per capelli secchi e danneggiati.

Serum
Siero

Repariert und pflegt Haare. Beseitigen Sie Frizz sofort. Stärkendes Serum, repariert von innen nach außen geschädigtes und gebrochenes Haar.

Ripara e ammorbidisce i capelli. Elimina l'effetto crespo all'istante. Siero rinforzante, agisce dall'interno verso l'esterno per riparare i capelli danneggiati e spezzati.

Stärkendes Shampoo mit Biotin und Keratin Shampoo fortificante con biotina e cheratina

Speziell formuliertes Shampoo und Maske mit Biotin (Vitamin h) und Keratin beugt der Talgsekretion und dem Haarausfall vor, reaktiviert das Haarwachstum und verleiht ihm Stärke und Dicke. Keratin nährt, repariert und regeneriert die Haarschuppenschicht und reduziert die Neigung zur Bildung von Spliss. Das Ergebnis ist kräftigeres Haar mit mehr Volumen und mehr Glanz. PH 5,5.

Shampoo e maschera appositamente formulati con biotina (vitamina h) e cheratina. La biotina previene la secrezione sebacea e la caduta dei capelli, riattivando la crescita, e apportando forza e spessore. La cheratina nutre, ripara e rigenera la cuticola del capello e riduce la tendenza alla formazione delle doppie punte. Il risultato sono capelli più forti, con più volume e più lucentezza. PH 5.5.



1 u.m.vta
12 box

1 L

REF.03663

Haarstärkende Kur Maschera fortificante

Mit Biotin und Keratin
Maschera fortificante
Con biotina e cheratina

1 u.m.vta
6 box

500 ml

REF.03674

1 u.m.vta
500 box

10 ml

REF.06805



CHLOROPHILE Shampoo Shampoo alla CLOROFILLA

1 u.m.vta
2 box

5 L

REF.04324



NEUTRALES Shampoo Shampoo NEUTRO

1 u.m.vta
2 box

5 L

REF.04325



Weichmachende Creme Nutriente

1 u.m.vta
2 box

5 L

REF.04326



Erstellt, um alle Haartypen sanft, häufig und gründlich zu waschen. Verleiht dem Haar mehr Glanz, ein gesünderes Aussehen und einen angenehmen Minzduft.

Formulato per lavare delicatamente, frequentemente e accuratamente tutti i tipi di capelli. Dona ai capelli più lucentezza, un aspetto più sano e un gradevole profumo di menta.

Shampoo für alle Haartypen, besonders geeignet für die tägliche oder häufige Anwendung. Es wäscht das Haar auf sanfte Weise, wobei der Ph-Wert der Haarkutikula erhalten bleibt. Schützt die Kopfhaut und verleiht ihr Gleichgewicht und Gesundheit.

Shampoo per tutti i tipi di capelli e particolarmente indicato per un uso quotidiano o frequente. Lava i capelli in modo delicato, mantenendo il PH della cute e dei capelli. Protegge il cuoio capelluto donandogli equilibrio e salute.

Conditioner mit Pflanzenextrakten, der die Haarfaser repariert, stärkt und das Schuppen der Haarfaser verhindert. Diese Extrakte verleihen dem Haar Weichheit, Glanz und Leuchtkraft und erleichtern das Styling.

Balsamo con estratti vegetali che riparano, rinforzano e prevengono la desquamazione della fibra capillare. Questi estratti donano ai capelli morbidezza, lucentezza e luminosità, favorendo l'acconciatura..

Weichmachende Creme HERBAL CREAM Nutriente HERBAL CREAM

Kraftvoll aufweichend und entwirrend. Es stellt das natürliche Gleichgewicht des Haares wieder her und gibt ihm sein gesundes und natürliches Aussehen zurück. Enthält pflegende Inhaltsstoffe und einen Kräuterduft. Ohne Parabene und Silikone.

Ha un grande potere ammorbidente e districante. Ripristina il naturale equilibrio dei capelli, ripristinando il loro aspetto sano e naturale. Contiene ingredienti ammorbidenti e un profumo di erbe. Senza parabeni o siliconi.

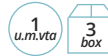

5 L

REF.06682

Auffrischende Haarkur Maschera riparatrice per capelli

Angereichert mit Arganöl, Keratin und Kollagen restrukturiert und pflegt es trockenes und dehydriertes Haar und verleiht ihm Glanz und Geschmeidigkeit. Repariert Schäden, die durch thermische Einflüsse verursacht wurden, und schützt vor Bruch.

Arricchita con olio di argan, cheratina e collagene che ristrutturano e nutrono i capelli secchi e disidratati, donando lucentezza e morbidezza. Ripara i danni causati dalle aggressioni termiche e li protegge dalle rotture.



400 ml

REF.06313

INTENSE BRIGHT COLOR Shampoo Shampoo INTENSE BRIGHT COLOUR

INTENSE BRIGHT COLOUR SHAMPOO ist die Ergänzung der technischen Produktlinie von TASSEL, angereichert mit Arganöl und Keratin. Es ist speziell für trockenes, gefärbtes, gebleichtes Haar und mit feuchtigkeitsspendenden, restrukturierenden und reparierenden Eigenschaften der Haarfaser geeignet. Die ideale Ergänzung zu unserer neuen KUR BRIGHT MASK, die mit Arganöl und Keratin angereichert und so formuliert ist, dass sie als Reparatür von geschädigtem Haar wirkt.

Lo Shampo INTENSE BRIGHT COLOR della linea di prodotti professionali TASSEL, arricchito con olio di argan e cheratina. Particolarmente indicato per capelli secchi, colorati, decolorati, grazie alle sue proprietà idratanti, ristrutturanti e riparatrici della fibra capillare. Il complemento ideale per la nostra NUOVA MASCHERA CAPILAR BRIGHT MASK arricchita con olio di argan e cheratina e formulata per agire come riparatore per i capelli danneggiati.



5 L

REF.06336

Shampoospender Dosatore

» Gibt mit jedem Druck 30 ml Shampoo ab
» Für 5-Liter-Behälter

» Dosa 30 ml di shampo ad ogni pressione
» Per le taniche da 5 litri



REF.07093

AROMA SENSATION Shampoos
Shampoo "AROMA SENSATION"1
u.m.vta6
box

Um den Marktbedürfnissen gerecht zu werden, lanciert, erweitert und erneuert TASSEL, mit seinem ständigen Innovationscharakter, seine Linie von Shampoos. NEUTRAL-SHAMPOO mit einem angenehmen Geruch von MELONE, ERDBEERE und KOKOSNUS. Alle sind so formuliert, dass eine tiefe Haar- und Kopfhautwäsche erreicht wird. Seine hohe Konzentration an aktiven Stoffen ermöglicht ein perfektes Waschen. Es verleiht dem Haar mehr Glanz und ein gesünderes Aussehen. Für den täglichen Gebrauch. Ph 5,5.

Per soddisfare le esigenze del mercato, TASSEL, grazie alla sua volontà di costante innovazione, lancia, amplia e rinnova la sua linea di shampoo sfusi. SHAMPOO NEUTRO dal gradevole profumo di MELONE, FRAGOLA e COCCO. Tutti formulati per ottenere un lavaggio profondo dei capelli e del cuoio capelluto. La loro alta concentrazione di principi attivi permette un lavaggio perfetto. Dona ai capelli più lucentezza e un aspetto più sano. Per uso quotidiano. Ph 5,5.

**Melone**
Melone**Erdbeere**
Fragola**Kokosnuss**
Cocco**Haarkur mit Kollagen 1l**
Maschera per capelli al collagene 1l1
u.m.vta5
box

Box mit 12 Behandlungen "wow effect" Confezione con 12 trattamenti "wow effect"



Mit Keratin, Arganöl und Haarseider

Behandlung angereichert mit:

- » **Keratin**, das die Seidigkeit des Haars erhöht, was für eine tiefe Hydratation sorgt, den Glanz intensiviert und hilft, die offenen Spitzen zu schließen. Bewahrt die Farbe und verbessert die Haargesundheit.
- » **Mit Seidenproteinen**: hydratisiert in der Tiefe, revitalisiert gefärbtes Haar und sorgt für Glanz.
- » **Arganöl**, repariert und restrukturiert Haar, das durch äußere Einflüsse beschädigt wurde, macht geschmeidiger, kräftigt und hydratisiert.

Con Cheratina, Olio di Argan e Seta

Trattamento arricchito con:

- » **Cheratina**, che aumenta la setosità dei capelli e produce un'idratazione profonda, intensifica la lucentezza e aiuta a sigillare le doppie punte. Mantiene il colore e migliora la salute dei capelli.
- » **Proteine della seta**, che idratano in profondità, rivitalizzano i capelli colorati e donano lucentezza.
- » **Olio di Argan**, ripara, ristruttura i capelli danneggiati dalle aggressioni esterne, ammorbidisce, nutre e idrata.



NEW

REF.07244



Reparatur-Explosion für das Haar in 5 Minuten Esplosione riparatrice per capelli in 5 min

Umschlag 1 **Flash-Effekt** + Umschlag 2 **Impact-Effekt**. Mischen Sie die beiden Umschläge und sorgen Sie für eine **REPARATUR-EXPLOSION**. Stellt die Gesundheit Ihres Haars mit nur einer Anwendung wieder her.

GEBRAUCHSANWEISUNG: Den Inhalt beider Umschläge in ein Metallgefäß mischen, bis eine homogene Emulsion entsteht. Durch Massieren des Haars von der Wurzel zu den Spitzen auftragen. 5 bis 10 Minuten einwirken lassen, je nach Zustand des Haars, und mit Wasser ausspülen.

Bustina 1 **Effetto flash** + Bustina 2 **Effetto impatto**. Mescolare le 2 bustine per generare una **ESPLOSIONE RIPARATRICE**. Recupera la salute dei tuoi capelli in un'unica applicazione.

COME USARE: Mescolare il contenuto di entrambe le bustine in una ciotola non metallica fino ad ottenere un'emulsione omogenea. Applicare massaggiando i capelli dalla radice alla punta. Lasciare agire da 5 a 10 minuti a seconda delle condizioni dei capelli e risciacquare con acqua.

Keratin-Nährhaarkur
Maschera nutritiva alla cheratina

Erstellt mit Keratin, das das Haar nährt, pflegt und seine Elastizität erhöht, indem es von der Wurzel bis zu den Spitzen repariert, es vor äußeren Angriffen schützt und die Neigung zur Bildung von Spliss reduziert.

Formula a base di cheratina, che nutre, ammorbidisce e aumenta l'elasticità dei capelli, riparandoli dalle radici alle punte, proteggendoli dalle aggressioni esterne e riducendo la tendenza a formare doppie punte.



100 ml

REF.03435



500 ml

REF.06948

Strandset mit Keratin
Kit da spiaggia alla cheratina

Strandset bestehend aus Sonnenschutzcreme für das Haar, nährenden Kur, Holzgriffbürste mit Balg, Plastikamm mit breiten Zinken, Haarklammer, Pinzette zum Zupfen der Augenbrauen und Doppelspiegel mit kleinem Kamm.

Kit da spiaggia composto da crema solare capillare, maschera nutriente, spazzola a soffietto in legno, pettine in plastica a setole larghe, pinza per raccogliere i capelli, pinzetta per depilare le sopracciglia e doppio specchio con pettine.



REF.03519



Neue
Formel
Nuova
formula

**BI-PHASIC Tassel**
BI-PHASIC Tassel**Vorteile**

- » Hydratation
- » Flexibilität
- » Geschmeidigkeit
- » Verleiht Volumen und Haarkur

Eigenschaften

Angereichert mit Leinsamenöl, welches das Haar mit Feuchtigkeit, Flexibilität und Geschmeidigkeit versorgt, sowie Weizenproteinen, die eine ähnliche Wirkung wie Keratin haben. Es macht das Haar elastischer, gibt mehr Volumen und wirkt wie ein natürlicher Conditioner. Speziell für trockenes und geschädigtes Haar.

Benefici

- » Idratazione
- » Flessibilità
- » Morbidezza
- » Dona volume e morbidezza

Che cos'è?

Balsamo arricchito con lino che fornisce idratazione, flessibilità e morbidezza ai capelli e proteine del grano che hanno effetti simili alla cheratina. Rende i capelli più elastici, con più volume e agisce come un balsamo naturale. Specifico per capelli secchi e danneggiati.



500 ml

REF.07369

NEW



Hitzeschutz Protettore termico

Anti-Frizz
Effetto anti-crespo



250 ml

REF.03343



Locken-Aktivator Attivatore ricci



250 ml

REF.03344



Flüssiges Keratin Cheratina liquida



250 ml

REF.03554



Spezifische Formel für den Schutz und die Pflege der Haare gegen äußere Einflüsse, die durch Trocknungsgeräte, die heiße Luft erzeugen, wie Haartrockner, Glätteisen und Lockenstäbe, entstehen. Seine Pflegespülung verhindert Kräuseln und macht das Haar handlicher und glänzender, wodurch die statische Aufladung vermieden wird.

Formula specifica per la protezione e la cura del capello dalle aggressioni prodotte dai dispositivi di asciugatura che generano aria calda, come asciugacapelli, piastre e arricciacapelli. Previene l'effetto crespo, lasciando i capelli più pettinabili e lucenti, evitando così l'effetto antistatico.

Seine innovative Formel erzeugt einen Film, der die Locken stärkt und belebt, ihnen mehr Definition und Elastizität verleiht und ihnen Feuchtigkeit spendet, ohne sie zu beschweren. Seine konditionierende Wirkung verleiht dem Haar Volumen und Dicke und macht es seidig, glänzend und definiert.

La sua formula innovativa crea un patina che rinforza e rivitalizza i ricci, donando loro più definizione, più elasticità e idratandoli senza appesantirli. Il suo effetto balsamo apporta volume e spessore, lasciando i capelli setosi, lucenti e vaporosi.

Flüssiges Keratin nährt, repariert und regeneriert sofort die Haarschuppenschicht. Es enthält Kollagen und Seidenproteine, die eine konditionierende Wirkung verleihen, wodurch gesünderes und kräftigeres Haar erzielt und Volumen, Weichheit und Glanz verbessert werden.

La cheratina liquida nutre, ripara e rigenera istantaneamente la cute del capello. Contiene collagene e proteine della seta, che apportano un effetto balsamo, ottenendo capelli più sani e forti e migliorando volume, morbidezza e lucentezza.

Lovely Curls Tassel Lovely Curls Tassel



Vorteile

- » Lockendefiniton
- » Maximale Hydratation,
- » Volumen
- » Natürliche Lockerheit für Ihr Haar

Eigenschaften

Pflegende Creme, die die Locken definiert. Es enthält Panthenol und Weizenproteine. Beseitigt Frizz und bietet definiert die Locken. Maximale Hydratation, Volumen und Lockerheit für Ihr Haar.

Benefici

- » Definisce i ricci
- » Massima idratazione
- » Volume
- » Movimento naturale dei capelli

Che cos'è?

Crema balsamo per definire i ricci. Contiene pantenolo e proteine del grano. Elimina l'effetto crespo e definisce i ricci. Massima idratazione, volume e movimento ai tuoi capelli.

NEW

250 ml

REF.07381



Haar-Serum**Siero All for Hair**

Haarschutzserum, mit Keratin, UV-Filter, Arganöl und Seidenproteinen Kein Spülen.

Siero protettivo per capelli, con cheratina, filtro UV, olio di argan e proteine della seta. Senza risciacquare.

10 Ergebnis nach einer Anwendung:

1. Repariert geschädigtes Haar
2. Glanz
3. Hitzeschutz
4. Aufweichend und Entwirrend
5. UV-Schutz
6. Frizz vermeiden
7. Verhindert gespaltene Spitzen
8. Bietet Volumen
9. Erleichtert das Kämmen
10. Erleichtert das Kämmen
11. Feuchtigkeits Tiefenspender

10 vantaggi in una sola applicazione:

1. Ripara i capelli danneggiati
2. Dona lucentezza
3. Protettore termico
4. Ammorbidisce e districa
5. Protezione UV
6. Previene l'effetto crespo
7. Previene le doppie punte
8. Dona volume
9. Facilita lo styling
10. Facilita lo styling
11. Idrata in profondità

120
u.m.vta

120
box

3 ml

REF.03930

120
u.m.vta

1
u.m.vta

12
box

250 ml

REF.03830

**Volumisierendes Pulver****Volumizzanti**

Ultraleichtes Mattierungspulver zur Erstellung von Texturen. Glatter und matter Effekt. Hält die Frisur und verleiht auch feinem Haar Volumen. Je mehr Sie von dem Produkt anwenden, desto mehr Kontrolle erhalten Sie und desto mehr unglaublichen Halt erhalten Sie. Für einen intensiveren Matteffekt auf das feuchte Haar auftragen, formen und trocknen lassen. Sie können das Produkt auch auf trockenes Haar auftragen, um die Kräuselung zusätzlich zu kontrollieren und die Weichheit zu erhöhen. Angereichert mit Keratin, das die Widerstandsfähigkeit des Haarkeratins fördert.

Opacizzante ultraleggera per dare volume. Morbido e con effetto opaco. Mantiene l'acconciatura e dona volume anche ai capelli fini. Applicando più prodotto, si ottiene un maggior controllo e una incredibile tenuta. Per un effetto opaco più intenso applicare sui capelli umidi modellandoli e lasciandoli asciugare. È inoltre possibile applicare il prodotto sui capelli asciutti per ottenere un ulteriore controllo dell'effetto crespo e una maggiore morbidezza. Arricchito con cheratina che favorisce la resistenza della cheratina capillare.



120
u.m.vta

1
u.m.vta

15
box

10 gr

REF. 06316



120
u.m.vta

1
u.m.vta

20
box

20 gr

REF. 06175

Wurzeln retuschieren Ritocca le radici



Temporäre Sprühfarbe.

Sofortige Farbe. Bedeckt sofort Wurzeln und graues Haar und fügt sich perfekt in Ihre Farbe ein. Schnelles und sichtbares Trocknen aller Haare. Es geht mit 1 oder 2 Wäschen.

- » Deckt Wurzeln und graues Haar ab
- » Temporäre Färbung
- » Schnell trocken

WIE BENUTZT MAN

VORBEREITUNG: Legen Sie ein Handtuch über die Schultern.

- » Gut schütteln und den Behälter aufrecht halten. Sprühen Sie ca. 15 cm von trockenem Haar. Nicht zu stark verdampfen, eine kleine Menge ist ausreichend. 1 Minute trocknen lassen und kämmen. Sprühen Sie ein zweites Mal für eine intensivere Farbe.
- » Verwenden Sie nach dem Sprühen der Wurzeln einen Kamm, um das Produkt von Ihren Wurzeln etwa 4 oder 5 Zentimeter entlang der Länge zu verteilen, damit Sie ein natürlicheres Ergebnis erzielen.

Colorazione spray temporanea.

Colore istantaneo. Copre istantaneamente radici ed i capelli grigi, fondendosi perfettamente con il tuo colore. Si asciuga molto velocemente, visibile su tutti i capelli. Si pulisce, con 1 o 2 lavaggi.

- » Copre radici e capelli grigi
- » Colorazione temporanea
- » Asciugatura rapida

NEW



COME USARE

PREPARAZIONE: Mettere un asciugamano sulle spalle.

- » Agitare bene lo spray e mantenerlo in posizione verticale, a circa 15 cm dai capelli asciutti. Non vaporizzare eccessivamente, una piccola quantità è sufficiente. Lasciate asciugare per 1 minuto e pettinare. Spruzzare una seconda volta per un colore più intenso.
- » Dopo aver colorato le radici, distribuire il prodotto dalle radici con un pettine di circa 4 o 5 centimetri su tutta la lunghezza del capello, in modo da ottenere un risultato più naturale.



REF.07277/50

Schwarz
Nero



REF.07277/67

Dunkelbraun
Castano
scuro



REF.07277/65

Hellbraun
Castano chiaro



REF.07277/66

Dunkelblond
Biondo scuro



REF.07277/76

Hellblond
Biondo chiaro



REF.07277/60

Rot
Rosso

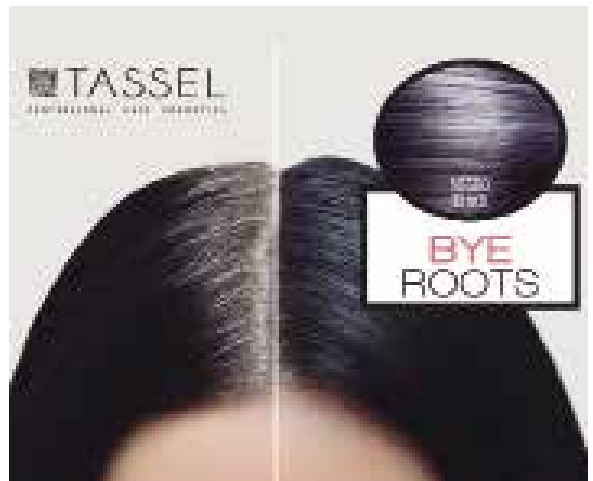

Haarfasern Fibre capillari



22 gr

- » Mit Dosiermöglichkeit
- » Für Männer und Frauen. Ideal bei Haardichteverlust. Tarnung von Bereichen mit wenig Haar schnell und natürlich
- » Haftet am Haar und verleiht ihm mehr Volumen und Dicke
- » Einfaches Auftragen durch Schütteln des Glases über die Applikationsfläche
- » Erhältlich in 6 Farben: schwarz, dunkelbraun, mittelbraun, hellbraun, dunkelblond und hellgrau passend zur natürlichen Haarfarbe

- » Con dosatore
- » Per uomini e donne. Ideale contro la perdita di densità. Nasconde le aree CON pochi capelli in modo rapido e naturale
- » Aderisce ai capelli donando loro maggior volume e spessore
- » Si applica facilmente agitando il barattolo sull'area di applicazione
- » Disponibile in 6 colori: nero, castano scuro, castano medio, castano chiaro, biondo scuro e grigio chiaro che si adattano al tono del colore naturale dei capelli



Schwarz · Nero

REF.06436/50

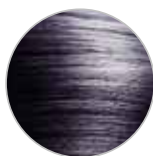

Hellgrau · Grigio chiaro

REF.06436/72

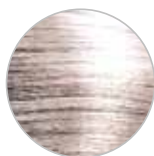

Dunkelblond · Biondo scuro

REF.06436/66

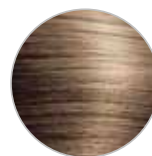

Dunkelbraun · Castano scuro

REF.06436/67

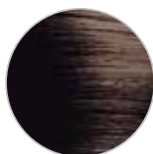

Mittelbraun · Castone medio

REF.06436/76

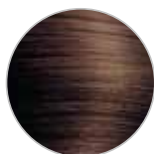

Hellbraun · Castone medio

REF.06436/65



Fixier-Zerstäuber Atomizzatore per fibra capillare



REF.07208

NEW

- » Benutzerfreundlich
- » Ermöglicht eine gleichmäßigere Verteilung der Haarfasern an bestimmten Stellen.
- » Ermöglicht, dass die Fasern viel leichter an Ihrem natürlichen Haar anhaften. Es wird eine geringere Menge des Produkts benötigt, um den gewünschten Look zu erzielen.
- » Leicht zu lagern

VERWENDUNG:

Geben Sie die Haarfasern in die Glasflasche und bringen Sie den Zerstäuber an, um sie zu pulverisieren. Drücken Sie hierfür die Pumpe nach oben und nach unten.

- » Facile da usare
- » Consente una distribuzione più uniforme delle fibre capillari in zone specifiche.
- » Permette alle fibre di aderire ai tuoi capelli naturali molto più facilmente. È necessario meno prodotto per ottenere l'aspetto desiderato.
- » Facile da riporre

COME USARE:

Versare le fibre dei capelli nella bottiglia di vetro e sistemare l'atomizzatore per nebulizzarle. Premere la pompetta a tale scopo.



Haarfaser-Lack

Lacca per fibra capillare



Für maximale Fixierung und Unterstützung der Fasern

Per una massima fissazione e tenuta delle fibre

100 ml

REF.06649



Verkaufsträger haarfasern (als geschenk)

Espositore per fibre capillari (regalo)



» Umfasst 6 Farbtöne für haarfasern + fixierlack

» Ref. 06436/50 Schwarz 22 g - Ref. 06436/72 Hellgrau 22 g - Ref. 06436/66 Dunkelblond 22 g - Ref. 06436/67 Dunkelbraun 22 g - Ref. 06436/76 - Mittelbraun 22 g - Ref. 06436/65 Hellbraun 22 g

» Ref. 06649 Fixierlack haarfasern 100 ml.

» Include 6 tonalità di fibra capillare + lacca fissante

» Rif. 06436/50 Nero 22g. - Rif. 06436/72 Grigio chiaro 22g. - Rif. 06436/66 Biondo scuro 22g. - Rif. 06436/67 Castano scuro 22g. - Rif. 06436/76 Castano medio 22g. - Rif. 06436/65 Castano chiaro 22g. - Rif. 06649 Lacca fissante fibre capillari 100 ml.



NEW

REF.07801

Tassel Kosmetik-Lacke, ideal für Steckfrisuren
Lacche Tassel Cosmetics, ideali per acconciature



» Normal
 » Normale



300 ml

REF.06268

750 ml

REF.06265

» Stark
 » Forte



300 ml

REF.06269

750 ml

REF.06266

Industrias Oriol 1942, S.L. bringt die neue Veredelungslinie "TASSEL HAARLACKE" auf den Markt, die mit Arganöl angereichert ist, das reich an ungesättigten Fettsäuren, Vitamin E sowie an Beta-Carotinoiden ist und eine hohe Hydratationskapazität besitzt, die das Haar erhält und ihm einen natürlichen Glanz und Schönheit verleiht.

Seine aktualisierte Zusammensetzung, die sehr substanziiell für das Haar ist, ermöglicht ein rationelleres Haarformen und bildet einen flexibleren und elastischeren Film, der in der Lage ist, das Haar vor äußeren Einflüssen wie Wind oder Feuchtigkeit zu schützen. Dank seiner Arganölkomponente kann jede Art von Frisur mit dem gewünschten Glanz, Volumen und Geschmeidigkeit erhalten werden.

Seine LONG LASTING Wirkung macht es ideal zum Glätten, für Locken, für Volumen, zum Hochstecken, und um unendlich viele Frisuren zu kreieren und den ganzen Tag auf natürliche Weise und ohne die Frisur zu belasten, zu Sie zu pflegen. Seine Zusammensetzung erlaubt ein leichtes Entfernen mit einem leichten Pinsel. Hinterlässt keine Rückstände.

Industrias Oriol 1942, S.L. lancia la nuova linea "LACCHE PER CAPELLI TASSEL", arricchite con olio di argan, un principio attivo ricco di acidi grassi insaturi, vitamina E, oltre a beta carotenoidi, che forniscono un'elevata capacità di idratazione e si prendono cura dei capelli donando loro una naturale lucentezza e bellezza.

La loro formula innovativa, molto nutritiva per i capelli, consente acconciature più strutturate formando una pellicola più flessibile ed elastica in grado di proteggere i capelli dagli agenti esterni come vento o umidità, e permettendo di mantenere qualsiasi tipo di acconciatura con la lucentezza, il volume e la setosità desiderati grazie al suo componente di olio di argan.

Il loro effetto LUNGA DURATA le rende ideale per lisciare, arricciare, volumizzare, acconciare, creare innumerevoli acconciature e mantenerle per tutta la giornata in modo naturale e senza appesantire l'acconciatura. La loro composizione permette una facile rimozione con una leggera. Non lascia residui.

Tassel Kosmetiklacke, ideal für Steckfrisuren
Lacche Tassel Cosmetics, ideali per acconciature



- » Extra stark
- » Extra forte



300 ml

REF.06270

750 ml

REF.06267



- » ECO
- » ECO

300 ml

REF.06271

LACA ECO TASSEL gibt dem Haar eine ausgezeichnete Fixierung, die ihm einen natürlichen Glanz verleiht und es gleichzeitig vor äußeren Einflüssen wie Wind, Feuchtigkeit usw. schützt. Mit den gleichen Eigenschaften wie die bisherigen Lacke, aber ohne umweltverschmutzende oder schädliche Gase für die Umwelt.

LACA ECO TASSEL dona ai capelli un'ottima tenuta e una lucentezza naturale proteggendoli dagli agenti esterni come vento, umidità, ecc. Con le stesse caratteristiche delle precedenti lacche, ma senza gas inquinanti o nocivi per l'ambiente.



Spangen und klammern

MOLETTE
E FERMAGLI

*Haarnadeln, Haarspangen,
Haarklammern, Haardiademe,
Haarklemmen, Haargummis...*

*Mollette, fermagli, forcine,
cerchietti, pinze, elastici...*



Geschichte des Clips und seines Hintergrunds

Storia delle clip e dei suoi predecessori

Der Ursprung der Nadeln zum Feststecken des Haars geht auf das Assyrische Reich und das alte Ägypten zurück, 25 Jahrhunderte v.Chr. Die gefundenen Überreste zeigen, dass es Nadeln aus Holz, Elfenbein, Bronze und anderen Metallen gab, und dass einige mit wertvollen Steinen dekoriert waren, was sie zu Luxusgegenständen machte.

Im alten China wurde der Übergang der jungen Leute in das Erwachsenenleben mit einer Zeremonie inszeniert, bei der ihnen eine Nadel für das Haar übergeben wurde.

Die Clip-Haarnadel, so wie wir sie heute kennen, wurde nach dem Ersten Weltkrieg von Luis Marcus erfunden, einem Kosmetikfabrikanten aus San Francisco. Die Verwendung des Clips war weit verbreitet, als die Frisur namens "Bob" in Mode kam, ein gerader Haarschnitt bis in Höhe des Kinns (daher ihr englischer Name "Bobby pin").



L'origine degli aghi per tenere i capelli risale all'impero assiro e all'antico Egitto, 25 secoli prima di Cristo. I resti trovati mostrano che esistevano aghi di legno, avorio, bronzo e altri metalli e che alcuni erano decorati con pietre preziose, diventando così oggetti di lusso.

Nell'antica Cina, il passaggio delle giovani donne all'età adulta era rappresentato da una cerimonia in cui veniva loro consegnato un ago per capelli.

La forcina a clip come è conosciuta oggi è stata inventata da Luis Marcus, un produttore di cosmetici di San Francisco, dopo la prima guerra mondiale. L'uso della clip si diffuse quando divenne di moda l'acconciatura conosciuta come "bob" o "caschetto", un taglio di capelli dritto fino al mento (da cui il nome in inglese "Bobby pin").



Ziel und Form

Obiettivo e forma

Der Clip ist ein kleines Teil aus gebogenem Stahl, das zur Aufnahme des Haars und zur Fixierung der Frisur verwendet wird.

La forcina è un piccolo pezzo di acciaio piegato utilizzato per raccogliere i capelli e tenere in posizione l'acconciatura.



Die Öffnung ist der offene Teil des Clips, durch den das Haar passen muss.

La bocca È la parte aperta della forcina, dove i capelli devono entrare.

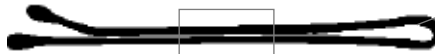

Die beiden Zinken des Clips drücken und stützen die Haarsträhne und befestigen den Clip.

Le due asticelle della clip sono quelle che tengono premuta la ciocca e tengono la forcina in posizione.

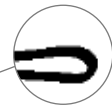

Das Auge des Clips hat zwei Funktionen:

Eine möglichst große Anzahl an Haaren aufzunehmen, und den Druck der Zinken zu erleichtern.
L'occhio della forcina ha due funzioni: Afferrare la massima quantità di capelli possibile e facilitare la pressione delle asticelle.

Herstellungsprozess

Processo di fabbricazione

Die Clips, die wir herstellen und vertreiben, sind aus Stahldraht mit einem hohen Gehalt an Carbon. Diese Legierung macht sie härter, flexibler und widerstandsfähiger, und ermöglicht ihre Verwendung für zahlreiche Zwecke, ohne die Kraft des Drucks der Zinken zu verlieren.

Der Herstellungsprozess unserer Clips verläuft in verschiedenen Schritten:

- 1.- Ziehen des Drahts
- 2.- Walzen
- 3.- Biegen des Clips
- 4.- Kugel und Anstrich
- 5.- An- oder Einpassung

Le forcine che produciamo e distribuiamo sono realizzate in filo di acciaio, ad alto contenuto di carbonio. Questa lega le rende più dure, flessibili e resistenti, permettendone l'utilizzo in più occasioni senza perdere la forza di pressione delle asticelle.

Il processo di produzione delle nostre forcine segue diversi passaggi:

- 1.- Trafilatura
- 2.- Laminatura
- 3.- Piegatura
- 4.- Gomma e verniciatura
- 5.- Confezionamento

DOPPELWELLEN Haarnadel
Mollete a DOPPIA ONDA

- » Kurze **DOPPELWELLEN**-Haarnadel für besseren Haarfestigung und langanhaltende Steckfrisuren
- » *Molletta ondulata per una migliore tenuta dei capelli e per acconciature di lunga durata*

- » Karton 24 Haarnadeln
- » *Confezione 24*



REF. 04934 REF. 04934/50

- » Schachtel 300 Haarnadeln
- » *Confezione 300*



REF. 04935 REF. 04935/50

**Matte Anti-Rutsch-Haarnadeln**
Mollette satin antiscivolo

- » Karton 24 Haarnadeln
- » Mit Kugel
- » *Confezione 24*



REF. 04484/50 REF. 04484/58 REF. 04484/69 REF. 04484/72

- » Schachtel 300 Haarnadeln
- » Mit Kugel
- » *Confezione 300*



REF. 04522/50 REF. 04522/69



Haarnadel · Mollette

MATTEHAARNADEL gewellt
Mollette SATIN ondulate1
u.m.vta
288
box1
u.m.vta
16
box

- » Karton 12 Haarnadeln
- » Mit Kugel

REF. 07133 REF. 07133/50

» Confezione 12

- » Schachtel 200 Haarnadeln
- » Mit Kugel

REF. 07134 REF. 07134/50

» Confezione 200

NEW



NEW

**Haarnadel gewellt**
Mollette ondulate12
u.m.vta
120
box1
u.m.vta
16
box

- » Karton 24 Haarnadeln
- » Mit Kugel

REF. 01609 REF. 01609/50

» Confezione 24

- » Kasten 300 Haarnadeln
- » Mit Kugel

REF. 01610 REF. 01610/50

» Confezione 300

**Haarnadel gewellt**
Mollette ondulate12
u.m.vta
96
box1
u.m.vta
16
box

- » Karton 24 Haarnadeln
- » Mit Kugel

REF. 01611 REF. 01611/50

» Confezione 24

- » Schachtel 150 Haarnadeln
- » Mit Kugel

REF. 01612 REF. 01612/50

» Confezione 150

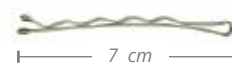

Haarnadel Box Confezioni di mollette



- » 700 Mini-Haarnadeln
- » Ohne Kugel

REF. 04088 REF. 04088/50

- » 700 mini-mollette

- » 300 Haarnadeln
- » Ohne Kugel

REF. 01604 REF. 01604/50

- » 300 mollet



- » 200 Haarnadeln
- » Mit Kugel

REF. 01606 REF. 01606/50

- » 200 mollette

- » 150 Haarnadeln
- » Mit Kugel

REF. 01608 REF. 01608/50

- » 150 mollete



Spangen auf Karton Confezione clip



- » 24 kleine schwarze Spangen
- » 24 clip nere

REF. 03482

- » 24 LeuchtfarbenSpangen
- » 24 clip fluorescenti

REF. 03481



- » 12 kleine schwarze Spangen
- » 12 clip nere

REF. 03480

- » 12 kleine Leuchtfarben Spangen
- » 12 clip fluorescenti

REF. 03479



JO-JO-Haarnadeln auf Karton
Confezione mollette yo-yo

- » 24 Haarnadeln
- » Mit Kugel
- » 24 mollette



REF. 01602

REF. 01602/50

ONDINA Haarnadeln auf Karton
Confezione mollette ONDINA

- » 12 Haarnadeln
- » Mit Kugel
- » 12 mollette

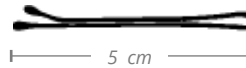

REF. 01603

REF. 01603/50

Ondina Haarnadeln auf Karton
Confezione mollette Ondina

- » 12 Haarnadeln
- » 12 mollette

REF. 01601

- » 24 Mini-Haarnadeln
- » 24 mini-mollette

REF. 02879

- » 12 Haarnadeln
- » 12 mollette

REF. 01607



REF. 01601/50



REF. 02879/50

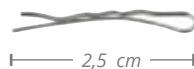

REF. 01607/50

**EUROSTIL- Haarnadeln auf Karton**
Confezione mollette EUROSTIL

- » 12 Haarnadeln
- » Mit Kugel
- » 12 mollette



REF. 01605

REF. 01605/50

Schachtel mit Haarnadeln
Confezioni di forcine1
u.m.vta 40
box» 72 Dutzend Haarnadeln mit Kugel
» 75 Dozzine di mollette

REF. 01856

REF. 01856/50

» Mit Kugel, 200 gr
» 200 gr

REF. 01863

REF. 01863/50



| 4,8 cm |



| 5 cm |

» 72 Dutzend Haarnadeln
» 72 dozzine di mollette

REF. 01855

REF. 01855/50

» Mit Kugel, 200 gr
» 200 gr

REF. 01862

REF. 01862/50



| 5,9 cm |



| 6 cm |

Schachtel mit 200 g Haarklammern
Confezione da 200 gr di forcine1
u.m.vta 70
box» 600 Haarklammern
» 600 forcine

REF. 01857

REF. 01857/50

» 150 Haarklammern
» 150 forcine

REF. 01858

REF. 01858/50



| 4,9 cm |



| 5 cm |

» 340 Haarklammern
» 340 forcine

REF. 01861

REF. 01861/50

» 150 Haarklammern
» 150 forcine

REF. 01860

REF. 01860/50



| 5 cm |



| 6 cm |

» 160 Haarklammern
» 160 forcine

REF. 01859

REF. 01859/50



| 7 cm |

» 95 - 100 Haarklammern
» 95 - 100 forcine

REF. 04327

REF. 04327/50

» 95 - 100 Haarklammern
» 95 - 100 forcine

REF. 04323

REF. 04323/50

1
u.m.vta 150
box

| 7,5 cm |



| 8,5 cm |



Packung Haarklammern Confezione di forcine

- » 20 Haarklammern, nicht sichtbar
- » 20 forcine invisibili

20
u.m.vta

20
box

REF. 07131

REF. 07131/50

Schachtel Haarklammern Confezioni di forcine

- » 400 Haarklammern, nicht sichtbar
- » 400 forcine invisibili

1
u.m.vta

16
box

REF. 07132

REF. 07132/50

NEW

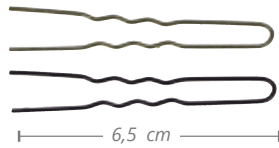

NEW

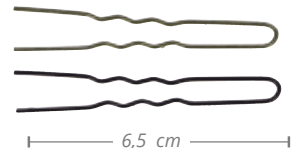

30
u.m.vta

30
box

- » 20 kleine, gewellte Haarklammern, nicht sichtbar

- » 20 forcine ondulate piccole invisibili

REF. 04089

REF. 04089/50

- » 500 kleine gewellte Haarklammern, nicht sichtbar

- » 500 forcine ondulate piccole invisibili

REF. 04087

REF. 04087/50

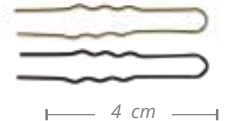
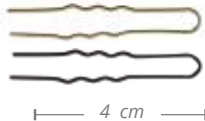

- » 20 Haarklammern, nicht sichtbar
- » 20 forcine invisibili

REF. 00030

REF. 00030/50

- » 400 Haarklammern, nicht sichtbar
- » 400 forcine invisibili

REF. 01616

REF. 01616/50

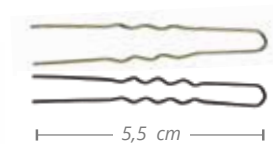
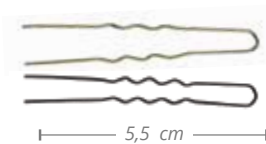

Packung Haarklammern Confezione di forcine

- » 20 Haarklammern, nicht sichtbar
- » 20 forcine invisibili

12 u.m.vta
20 box

REF. 00701 REF. 00701/50



Schachtel Haarklammern Confezioni di forcine

- » 400 Haarklammern, nicht sichtbar
- » 400 forcine invisibili

1 u.m.vta
16 box

REF. 01617 REF. 01617/50



12 u.m.vta
12 box

- » 20 glatte Haarklammern für Dutt

» 20 forcine semplici

REF. 04532 REF. 04532/50



- » 150 glatte Haarklammern für Dutt

» 150 forcine semplici

1 u.m.vta
16 box

REF. 04539 REF. 04539/50



12 u.m.vta
12 box

- » 20 gewellte Haarklammern, nicht sichtbar

» 20 forcine ondulate invisibili

REF. 04533 REF. 04533/50

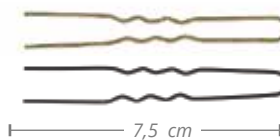

- » 150 gewellte Haarklammern, nicht sichtbar

» 150 forcine ondulate invisibili

1 u.m.vta
16 box

REF. 04540 REF. 04540/50

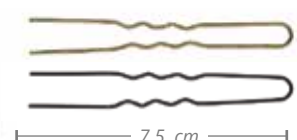

Packung Haarklammern Confezione di forcine

» 10 gebogene
Haarklammern für Dutt

» 10 forcine ricurve



REF. 04534 REF. 04534/50

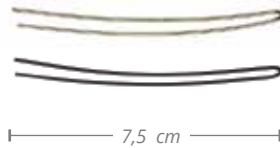

Schachtel Haarklammern Confezioni di forcine

» 150 gebogene
Haarklammern

» 150 forcine ricurve



REF. 04541 REF. 04541/50



12
u.m.vta 240
box

» 10 gebogene
Haarklammern, nicht
sichtbar

» 10 forcine ricurve
invisibili



REF. 04535 REF. 04535/50



» 150 gebogene
Haarklammern, nicht
sichtbar

» 150 forcine ricurve
invisibili



REF. 04542 REF. 04542/50



12
u.m.vta 240
box

» 20 gewellte Haarklammern,
nicht sichtbar

» 20 forcine ondulate invisibili



REF. 04531 REF. 04531/50

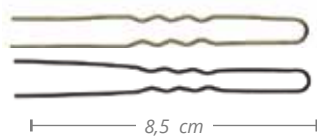

» Schachtel 150 gewellte
Haarklammer, nicht
sichtbar

» Confezione 150 forcine
ondulate invisibili



REF. 04538 REF. 04538/50

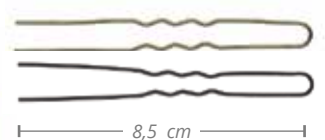

Packung Haarklammern Confezione di forcine

- » 20 glatte Haarklammern für Dutt
- » 20 forcine semplici



REF. 04530 REF. 04530/50



Schachtel Haarklammern Confezioni di forcine

- » 150 glatte gebogene Haarklammern
- » 150 forcine semplici



REF. 04537 REF. 04537/50



- » 6 gebogene Haarklammern
- » 6 forcine ricurve

REF. 04529 REF. 04529/50



- » 75 gebogene Haarklammern
- » 75 forcine ricurve

REF. 04536 REF. 04536/50

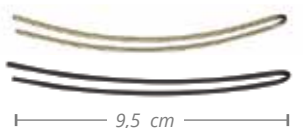

Haarklammer mit Perle Forcine con perla

12
u.m.Vta

240
box

- » 6 große Zier-Haarklammern mit weißer Perle
- » 6 forcine con perla bianca grande

REF. 03209 REF. 03209/50

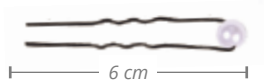

- » 12 Zier-Haarklammern mit kleiner weißer Perle
- » 12 forcine con perla bianca piccola

REF. 03212 REF. 03212/50

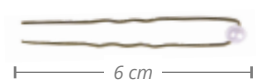

12
u.m.Vta

120
box

- » 6 Zier-Haarklammern mit großer silberner Perle
- » 6 forcine con perla argento grande

REF. 03210 REF. 03210/50

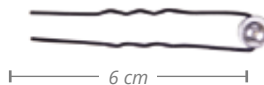

- » Packung mit 12 Zier-Haarklammern mit kleiner silberner Perle
- » Confezione da 12 forcine con perla argento piccola

REF. 03213 REF. 03213/50



- » 6 Zier-Haarklammern mit großer goldener Perle
- » 6 forcine con perla dorata grande

REF. 03211 REF. 03211/50

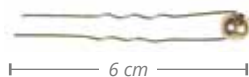

- » 12 Zier-Haarklammern mit kleiner goldener Perle
- » 12 forcine con perla dorata piccola

REF. 03214/50

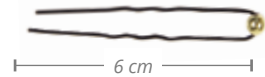

Magnetisches Armband
Braccialeto magnetico

Dank unseres Magnetarmbandes haben Sie alle Haarnadeln und Haarklammern immer griffbereit, um bequemer arbeiten zu können.

Per lavorare con più comfort, avere tutte le mollette e le forcine a portata di mano grazie al nostro braccialeto magnetico.



REF. 03631

Magnetisches Armband
Braccialeto magnetico

Schachtel mit Metall Klemmen
Confezioni becchi in metallo

- » 120 kleine Klemmen
- » Breiter Kopf
- » Ref. 92

REF. 01657

- 120 kleine Klemmen
- Schmäler Kopf
- Ref. 91

REF. 01656

- » 120 becchi piccoli
- » Testa larga
- » Rif. 92

- » 120 becchi piccoli
- » Testa stretta
- » Rif. 91



- » 120 zweischenklige Klemme
- » Ref. 94

REF. 01658

- » 120 mittlere Klemmen
- » Ref. 90

REF. 01655

- » 120 becchi a doppia levetta
- » Rif. 94

- » 120 becchi medi
- » Rif. 90



- » 120 große Klemmen
- » Ref. 95

REF. 01659

- » 60 gebogene Klemmen
- » Ref. 93

REF. 01830

- » 120 becchi grandi
- » Rif. 95

- » 60 becchi ricurvi
- » Rif. 93



12 Metallklemmen S
*Dodic becchi in metallo S*12
u.m.vta 96
boxS
REF. 00057

4,5 cm

M
REF. 00058

5 cm

L
REF. 00059

6,2 cm

12 Edelstahl-klemmen
Dodici becchi in acciaio inossidabile» P-20
» P-2012
u.m.vta 96
box

S

REF. 01641



5,3 cm

» P-30
» P-3012
u.m.vta 96
box

M

REF. 01642



6,7 cm

» P-50-Kurve
» Curvo P-501
u.m.vta 100
box

L

REF. 01647

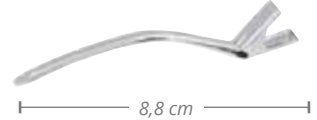

8,8 cm

Karton Klemmen
Confezione di becchi» 6 Metall-Trennklemmen
» Verchromt12
u.m.vta 36
box

REF. 00804

» 6 becchi separatori in
metallo
» Cromati

11,7 cm

» 6 gebogene
Klemmen

» 6 becchi ricurvi

12
u.m.vta 36
box

REF. 00093



11,7 cm

» 6 Metall-Trennklemmen
» Farbige12
u.m.vta 36
box

REF. 00803

» 6 becchi separatori in
metallo
» Colori

11,7 cm

Karton 10 Metallklemmen
Confezione 10 Becchi in metallo12
u.m.vta 96
box

- » Doppelte Schenkel Klemmen
- » Becchi in metallo doppio

S

REF. 00094



4,5 cm

M

REF. 00090



5,5 cm

L

REF. 00095



6,5 cm

Karton-Metallklemmen
Confezione becchi in metallo

- » 10 kleine Metallklemmen
- » Schmäler Kopf

12
u.m.vta 96
box

- » 10 kleine Metallklemmen
- » Breiter Kopf

12
u.m.vta 96
box

- » 12 gebogene Aluminium-Klemmen

12
u.m.vta 96
box

- » 10 becchi piccoli in metallo
- » Testa stretta

S

REF. 00091



4,5 cm



4,5 cm

S

REF. 00092

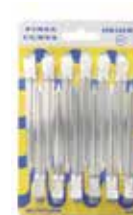

8,8 cm

- » 6 gebogene Kunststoffklammern

1
u.m.vta 100
box

- » Farbig
- » 6 becchi ricurvi in plastica
- » Colori

REF. 00055



8,3 cm

- » 6 professionelle Kunststoffklemmen

50
u.m.vta 50
box

- » 6 becchi professionali in plastica

REF. 00075



12 cm

- » 6 Kunststoffklemmen Herzform

12
u.m.vta 48
box

- » 6 becchi in plastica a forma di cuore

REF. 00086



9,8 cm

Schachtel mit 60 kleinen Plastikklammen
Confezione da 60 fermagli in plastica piccoli

6 cm



REF. 00046

Schachtel mit 60 mittleren Kunststoffklammen
Confezione da 60 fermagli in plastica medi

6,22 cm



REF. 00056

Schachtel mit 60 großen Plastikklammen
Confezione da 60 fermagli in plastica grandi

6,53 cm



REF. 00066

Set Frisur Kunststoffklammen
Set per acconciature

6 cm



REF. 00687

Hilfs-Klemmen
Pinza assistente

REF. 04369

Hält das Haar leicht, ohne es zu verheddern und ohne die Frisur zu beschädigen. Schlichtes und doch elegantes Design.

Ein Teil der Klemme hält einen Strang und der andere Teil mit Borsten hält einen anderen Strang. Es ist, als hätte man eine Salonassistentin zu Hause. Um eine Strähne zu färben oder herzustellen, folgen Sie den nachstehenden Anweisungen:

1. einen Mittelscheitel im Haar machen und dann die Farbe auftragen

Trennen Sie die erste Haarsträhne ab, halten Sie es mit der Hilfsklemme fest und tragen Sie dann die Farbe auf diese Strähne auf.

3. das nächste Büschel herausziehen, auf die Klemme legen und mit den Zinken festhalten

4. Wiederholen Sie die Operation, bis die Behandlung abgeschlossen ist

Tiene i capelli facilmente senza aggrovigliarli e senza rovinare l'acconciatura. Design semplice ed elegante.

È come avere un professionista di un salone di bellezza un'altra ciocca. Per tingere o fare delle meches, segui le istruzioni:

1. Fai una riga centrale tra i capelli e poi applica il colore

2. Separa la prima ciocca di capelli, fissala utilizzando la pinza ausiliaria e quindi applica il colore a questa ciocca

3. Separa la ciocca successiva, posizionala sulla pinza e tienila saldamente usando le punte

4. Ripeti l'operazione fino al completamento dell'applicazione del trattamento



11 cm

» Blisterpackung mit 2 speziellen Trennklemmen
» Blister 2 mollette speciali di separazione

**Box Anti-Rutsch Klemmen**
Confezione becchi antiscivolo

» 4 Anti-Rutsch-Klemmen
» Mit Gummi

» 4 fermagli antiscivolo
» Con elastico



REF. 04368



11 cm

» 6 Anti-Rutsch-Klemmen
» Mit Gummi

» 6 Becchi antiscivolo
» Con elastico



REF. 04376



11 cm

Schachtel mit 6 rostfreien Klemmen
Confezione pinze antiossidanti

» Mit Zähnen
» Dentati



REF. 03259



10 cm

Beutel mit 6 Metall-Kunststoff-Klemmen
Confezione da 6 becchi in metallo-plastica

- » Farbsortiment
- » Assortimento di colori



S

REF. 02525/99



10 cm

L

REF. 02524/99



12 cm

Beutel mit 4 Klemmen DRAGON
Buste da 4 pinze DRAGON

REF. 04374



9 cm



REF. 03059



11 cm



REF. 04375



14 cm

Beutel mit 6 schwarzen Plastikklammern
Busta da 6 becchi neri in metallo

REF. 02526

- » Mit Gummi
- » Con gomma



11 cm

Schachtel mit 6 Anti-Rutsch-Klemmen
Confezione da 6 becchi antiscivolo

REF. 04741

- » Mit Gummi
- » Con elastico



12 cm

Karton 4 Klemmen mit schwarzem Gummi
Confezione 4 fermagli con gomma nera

- » Schwarze Klemmen mit einem Gummiband, um keine Abdrücke auf den Haaren zu hinterlassen. Sehr nützlich für die Haarentfernung in Make-up-Sitzungen, da sie keine Spuren hinterlassen.

- » Fermagli neri con gomma per non lasciare segni sui capelli. Molto utili per separare i capelli nelle sedute di trucco poiché non lasciano segni.

REF. 06388



6 cm

REF. 06389



8,2 cm

Beutel mit 12 Klemmen
Busta da 12 pinzette1 u.m.vta
20 boxS ●
REF. 04421S ●
REF. 04422L ●
REF. 04423L ●
REF. 04424**Beutel mit 6 Heftklemmen mit großem Klemmbereich aus Kunststoff**
Busta da 6 pinzette con ampio separatore in plastica12 u.m.vta
48 box● ● ● ● ● ●
REF. 00081● ● ● ● ● ● ● ● ● ●
REF. 00081/76●
REF. 00081/50**Beutel mit 6 großen Heftklemmen, Farbsortiment**
Busta da 6 pinzette in plastica grandi, colori assortiti30 u.m.vta
30 box● ● ● ● ● ●
REF. 00078●
REF. 00078/51●
REF. 00078/53**Klemmen herz, super-mini**
Mini-pinzette a cuore12 u.m.vta
600 box● ● ● ● ● ●
REF. 00143●
REF. 00143/50●
REF. 00143/51**Beutel mit 6 Trennklemmen**
Busta da 6 pinzette di separazione1 u.m.vta
20 box●
REF. 04738

Supergroße Klammer Herz

Pinzetta con cuori super grande

6
u.m.vta

72
box



10,8 cm

XL ●

REF. 00073/51



10,8 cm

XL ●

REF. 00073/50

Große Klammer Herz

Pinzetta con cuori grande

6
u.m.vta

120
box



8,5 cm

L ●

REF. 00071/51



8,5 cm

L ●

REF. 00071/50

Klammer Herz klein

Pinzetta con cuori piccola

12
u.m.vta

120
box



5,9 cm

S ●

REF. 00100/50



5,9 cm

S ●

REF. 00100

» Marmorierte Farben
» Colori marmorizzati



5,9 cm

S

REF. 00100/52

Klammer Herz, mini

Mini-pinzetta con cuori

12
u.m.vta

600
box



3,4 cm

XS ●

REF. 00072



3,4 cm

XS ●

REF. 00072/52

Beutel mit 6 Aluminiumklammern
Busta da 6 pinzette in alluminio

12
u.m.vta

96
box



8,9 cm

L

REF. 00070



7,6 cm

S

REF. 00080

Beutel 12 Kunststoffklammern, groß
Busta da 12 pinzette in plastica, grandi

12
u.m.vta

36
box



8 cm

L

REF. 00084

Beutel mit 6 Klammern, klein, Plastik
Busta da 6 pinzette in plastica, piccole

12
u.m.vta

48
box



5,6 cm

S

REF. 00082



8 cm

L

REF. 00084/50



5,6 cm

S

REF. 00082/76

Beutel mit 6 Klammern, große Kunststoff farbig
Busta da 6 pinzette in plastica, grandi a colori assortiti

12
u.m.vta

36
box



8,2 cm

REF. 00083

Stirnband aus Polyamid, farblich sortiert
Cerchietto in poliammide, colori assortiti

12
u.m.vta

12
box

S

REF. 01914

M

REF. 01086

L

REF. 01087

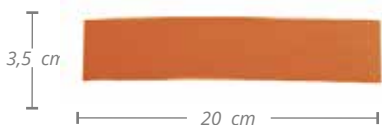

Karton 12 Haargummis mit Haken

Confezione 12 elastici con gancio



REF. 00640



REF. 00637

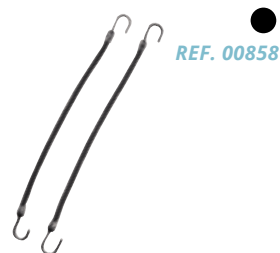

REF. 00858

Karton 24 Haargummis, Schwanz

Confezione 24 elastici, per coda

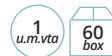

REF. 00634



REF. 00635

Karton 24 große Haargummis

Confezione 24 elastici grandi



» Polyamid
» Poliammide

REF. 00812

Karton 24 kleine Haargummis

Confezione 24 elastici piccoli



» Polyamid
» Poliammide



REF. 00812/50

REF. 00812/69



REF. 00811/50

REF. 00811/69

Beutel 12 Mini-Haargummis

Busta da 12 mini elastici



REF. 03384/50



REF. 03384

Beutel 10 Haargummis gerippt

Busta da 10 elastici



REF. 03383/50



REF. 03383

Pack 2 Spiral Haargummi
Confezione da 2 elastici a spirale12
u.m.Vta12
box

REF. 04840/50



REF. 04840/69



REF. 04840/56



Ø55



REF. 04807/50



REF. 04807/69



REF. 04807/56



Ø45



REF. 04806/50



REF. 04806/69



REF. 04806/56



Ø35



Karton 24 farbige geflochtene Haargummis
Confezione da 24 elastici intrecciati colorati1
u.m.vta 16
box

REF. 02261

Karton 24 schwarze geflochtene Haargummis
Confezione da 24 elastici intrecciati neri1
u.m.vta 16
box

REF. 02261/50

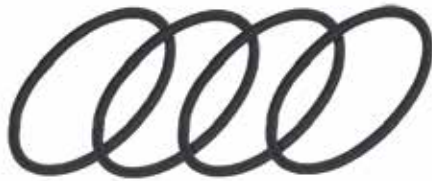
Karton 48 schwarze gefütterte Haargummis
Confezione da 48 elastici chiusi neri1
u.m.vta 24
box

Ø5 cm

REF. 03486

Beutel 5 Silikon Haargummis
Busta da 5 elastici in silicone1
u.m.vta 100
box

REF. 03467/50

REF. 03467/69

REF. 03467/99

Beutel mit 50 TPU-Gummiringen für Frisuren
Busta da 50 elastici per acconciature in TPU

- » Nicht abrasiv
- » Sehr widerstandsfähig
- » Nicht-toxisch
- » Ideal zum Flechten und Stecken

REF. 06808

REF. 06809

REF. 06810

REF. 06811

- » Non abrasivi
- » Molto resistenti
- » Non tossici
- » Ideali per trecce e chignon

**Beutel mit 2000 elastischem Gummiringen**
Busta da 2000 elastici

- » 100 gr. Ca.
- » 100 gr. ca.

REF. 03397

**Anti-Laus Haargummi**
Elastico anti pidocchi

- » Versetzt mit Pilgrim, einer Komponente, die wirksam und dauerhaft Läuse und andere Insekten abwehrt
- » Nachweislich 99% wirksam gegen Läuse
- » Anti-allergisch und geruchlos
- » Weicher Stoff
- » Wir gewährleisten 100 Wäschen, ohne ihre Wirksamkeit zu verlieren



REF. 04717



REF. 04718

- » Formulato con permetrina, un componente efficace e di lunga durata per respingere i pidocchi e altri insetti
- » Comprovata efficacia contro i pidocchi al 99%
- » Antiallergico e inodore
- » Tessuto morbido
- » Garantiamo 100 lavaggi senza perdere l'efficacia



REF. 04719



REF. 04928

Dekorierter Turban

Turbante decorato

1
u.m.vta

10
box

Eleganz, Glamour und Komfort vereinen sich in unserer Linie nahtlos bestickter Turbane, die vollständig in Spanien entworfen und hergestellt werden. Verschiedene Farben, um sie bei jeder Gelegenheit zu tragen. Eine ideale Ergänzung für die modernste Frau. 6 Modelle verfügbar. 100% Polyester.

Eleganza, glamour e comfort si uniscono nella nostra linea di turbanti ricamati senza cuciture, progettati e prodotti interamente in Spagna. Colori vari per indossarli in ogni occasione. Un complemento ideale per la donna moderna. 6 modelli disponibili. 100% poliestere.

» Schwarz
» Nero

REF. 06055/50



» Blau
» Blu

REF. 06055/59



» Grün
» Verde

REF. 06055/62



» Beige
» Beige

REF. 06055/65



» Rosa
» Rosa

REF. 06055/70



» Grau
» Grigio

REF. 06055/72



» Granat
» Granata

REF. 06055/73



1
u.m.vta

100
box

Beutel 6 bunt dekorierter Turbane

Busta di 6 turbanti decorati colorati

REF. 06055/99



EURO
stil



Turbantes decorados

www.eurostil.com

Haarnadeln mit Perlen 2 Stk.
Fermagli con perle 2 unità

REF. 06937



REF. 06930



REF. 06932



REF. 06933



REF. 06934



REF. 06935



REF. 06936



REF. 06938



Rechteckige Perlenklemme 2 Stk.
Fermagli rettangolari con perle 2 unità

REF. 06939

**Haarnadel mit weissen facettierten Glaskugeln 2 Stk.**
Fermagli con sfere di cristallo bianco sfaccettato 2 unità.

REF. 06931

**Haarnadeln Goldfarben mit Strasssteinen 2 Stk.**
Fermagli con strass 2 unità

REF. 06928



REF. 06929

**Stirnband mit großen Perlen 2 Stk.**
Cerchietto con perle grandi 2 unità

REF. 06940

**Haarspange mit Perlen 2 Stk.**
Fermaglio con perle 2 unità

REF. 06941



05

Papier

CARTA

*Handtücher, Ringlets,
Halspapier...*

*Salivette, carta permanente,
carta da collo...*



Packung mit 75 Handtüchern CELLULOSE Confezione da 75 salviette CELLULOSA

- » Speziell Maniküre
- » Speciale per manicure

50 gr/m²

REF. 04204

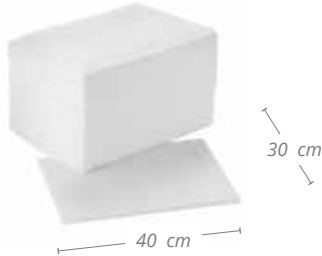

Packung mit 90 Handtüchern CELLULOSE Confezione da 90 salviette CELLULOSA

55 gr/m²

REF. 04076



Packung mit 25 SPUNLACE Handtüchern Confezione da 25 salviette SPUNLACE

- » Gefaltet auf 20 x 20 cm
- » 50% Polyester / 50% Viskose

- » Piegate 20 x 20 cm
- » 50% poliestere / 50% viscosa

50 gr/m²

40 x 90 cm

REF. 04916

50 gr/m²

40 x 80 cm

REF. 03221



Packung mit 100 Handtüchern SPUNLACE Confezione da 100 salviette SPUNLACE

- » Superabsorbierend
- » Ultra assorbenti



REF. 03283

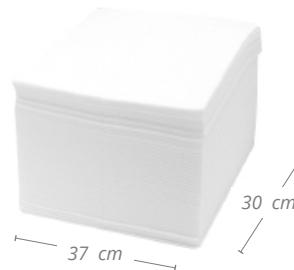

Beutel 100 Handtücher SPUNLACE Confezione da 100 salviette SPUNLACE

- » Zusammensetzung: 50% Viskose / 50% Polyester
- » Von hoher Widerstandskraft und Absorptionsfähigkeit, vielseitig, praktisch und Einweg.
- » Komplet latexfrei, extra weich im Griff
- » Superabsorbierend
- » Composizione 50% viscosa / 50% Poliestere
- » Altamente resistente e assorbente, versatile, pratico e usa e getta.
- » Completamente privo di lattice, extra morbido al tatto
- » Ultra assorbenti

50 gr/m²

REF. 07301



NEW

Beutel 35 Handtücher SPUNLACE Confezione da 35 salviette SPUNLACE

- » Superabsorbierend
- » Gefaltete Handtücher

- » Ultra assorbenti
- » Salviette piegate

50 gr/m²

REF. 04509

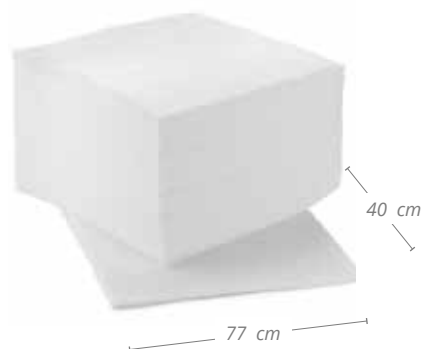

**Supergroßes Dauerwellen Papier**
Carta permanente ultra grande

REF.01230

- » Spender-Box 1000 Blatt
- » Superstark. Absorbierend und porös

» Dispenser box, 1000 fogli
» Extra forte, assorbente e poroso

**Dauerwellen Papier**
Carta permanente

REF.01136

- » Spenderbox 500 Blatt
- » Dispenser 500 fogli

**Perforiertes Dauerwellenpapier**
Carta permanente perforata

REF.04430

- » Schachtel 1000 Blatt Papier
- » Confezione da 1000 fogli

**Dauerwellen Papier**
Carta permanente

REF.00667

- » Schachtel 1000 Blatt
- » Confezione da 1000 fogli

**POLLIE-Spender**
Dispenser POLLIE

REF. 00802

- » Spender 20 Einheiten x 200 Blatt POLLIE-Ringlet-Papier

» Dispenser 20 confezioni x 200 fogli di carta POLLIE ringlet

**RINGLETS-Spender**
Dispenser RINGLET

REF. 00656

- » Spender 20 Einheiten x 200 Blatt Ringletpapier

» Dispenser 20 libretti x 200 fogli di carta ringlet



Armband Ringlet Papier Polsino per carta ringlet



REF.00657/50



REF.00657

Rolle Kreppansatzpapier für den Hals 100 Stück Rotolo di carta da collo adesiva, 100 servizi



REF. 00681

- » Blauer Klebstoff für einfaches Kleben und Platzieren
- » Hochwertige Qualität
- » Schnelle und perfekte Passform
- » Hygienischer Einmalgebrauch
- » Einwegpapier
- » Elastisch und anpassbar an jeden Hals
- » Entwickelt für professionelle Friseure und Barbieri
- » Verhindert Juckreiz und Brennen am Hals

- » *Adesivo blu per facile fissaggio e posizionamento*
- » *Qualità premium*
- » *Fissaggio perfetto e veloce*
- » *Monouso e igienico*
- » *Carta usa e getta*
- » *Elastico regolabile a ogni collo*
- » *Progettato per parrucchieri e barbieri professionisti*
- » *Evita il prurito e il bruciore al collo*



Papierrollenhalter Portarotolo per carta da collo

- » Halter für Kreppansatzpapier
00681, 04651, 06596, 06927
- » Portarotolo per carta da collo
00681, 04651, 06596, 06927



REF. 00800

- » Material: abs schwarz
- » Kann an der wand aufgehängt werden
- » Materiale: abs nero
- » Può essere appeso alla parete



REF. 06803



06

Ausbildung

FORMAZIONE

*Traingsköpfe, Stative,
Tischhalterung...*

*Teste studio, treppiedi, supporti da
tavolo con morsetto ...*



Schaufensterpuppen-Kopf, 100% NATURHAAR

Teste studio CAPELLI 100% NATURALI

Mit Halterung
Con supporto incluso



- » 42 Implantate pro cm²
- » 6-7 Haare pro Implantat
- » ca. 260 Haare pro cm²
- » Zum Schneiden, Bleichen, Färben, Dauerwellen, Styling, Steckfrisuren, Trocknen und Glätten
- » Maximale Temperatur 180°C
- » Klassisches 90°-Implantat

- » 42 impianti per cm²
- » 6-7 capelli per impianto
- » 260 capelli circa per cm²
- » Per tagliare, decolorare, tingere, permanente, acconciature, asciugatura e piastra
- » Temperatura massima 180°C
- » Impianto classico 90°

Kastanie · Castano



REF. 01455



REF. 00624



REF. 00603



REF. 01142

Sehr hellblond · Biondo molto chiaro

- » Nicht bleichen
- » Non decolorare



REF. 04251

Hellblond · Biondo chiaro

- » Ohne Wimpern
- » Bleichen
- » Senza ciglia
- » Non decolorare



REF. 04586

Schaufensterpuppen-Kopf, 100% NATURHAAR
Testa studio, 100% CAPELLI NATURALI

 Halterung nicht inbegriffen
 Supporto non incluso

- » 42 Implantate pro cm²
- » 6-7 Haare pro Implantat
- » ca. 260 Haare pro cm²
- » Zum Schneiden, Bleichen, Färben, Dauerwellen, Styling, Steckfrisuren, Trocknen und Glätten
- » Maximale Temperatur 180°C
- » Klassisches 90°-Implantat

- » 42 impianti per cm²
- » 7-8 capelli per impianto
- » 320 capelli circa per cm²
- » Per tagliare, decolorare, tingere, acconciare, asciugatura e piastra
- » Temperatura massima 180°C

Hellbraun · Castano chiaro

» Klassisches Implantat

 » *Impianto classico*

35 - 40 cm

Ø 50

Leia
REF. 06642

» Natürliche Implantate

 » *Impianto naturale*

35 - 40 cm

Ø 50

Amber
REF. 06643

» Natürliche Implantate

 » *Impianto naturale*

45 - 50 cm

Ø 50

Jenny
REF. 06644

» Natürliche Implantate

 » *Impianto naturale*

55 - 60 cm

Ø 50

Daisy
REF. 06645

» Natürliche Implantate 45°

 » *45° impianto naturale*

20 - 30 cm

Ø 54

Lucy
REF. 06149

» Klassisches Implantat 90°

 » *90° Impianto classico*

20 - 30 cm

Ø 54

Lucy
REF. 04910

**Kastanienbrauner Schaufensterpuppen-Kopf,
100% NATURHAAR**
Testa studio castano, CAPELLI 100% NATURALI

Halterung nicht inbegriffen
Supporto non incluso



- » Natürliches Implantat 45°.
- » Mit Wimpern
- » 42 Implantate pro cm²
- » 6-7 Haare pro Implantat
- » ca. 260 Haare . pro cm²
- » Zum Schneiden, Bleichen, Färben, Dauerwellen, Styling, Steckfrisuren, Trocknen und Glätten
- » Maximale Temperatur 180°C

- » Impianto naturale 45°
- » Con ciglia
- » 42 impianti per cm²
- » 6-7 capelli per impianto
- » 260 capelli circa per cm²
- » Per tagliare, decolorare, tingere, permanente, acconciature, asciugatura e piastra
- » Temperatura massima 180°C



Kastanienbraun Dunkel · Castano scuro

Emily

REF. 04905



35 - 40 cm

Ø 54

Lisa

REF. 04906



45 - 50 cm

Ø 54

Rose

REF. 04907



55 - 60 cm

Ø 54

Schaufensterpuppen-Kopf, 100% NATURHAAR

Testa studio, CAPELLI 100% NATURALI

Halterung nicht inbegriffen
Supporto non incluso



- » Mit Wimpern
- » Natürliche Implantate 45°
- » 42 Implantate pro cm²
- » 6-7 Haare pro Implantat
- » ca 260 Haare . pro cm²
- » Zum Schneiden, Bleichen, Färben, Dauerwellen, Styling, Steckfrisuren, Trocknen und Glätten
- » Maximale Temperatur 180°C

- » Con ciglia
- » Impianto naturale 45°
- » 42 impianti per cm²
- » 6-7 capelli per impianto
- » 260 capelli circa per cm²
- » Per tagliare, decolorare, tingere, permanente, acconciature, asciugatura e piastra
- » Temperatura massima 180°C

Schwarz · Nero

- » Remy Haar
- » Capelli remy



40 - 45 cm

Ø 54

Chloe

REF. 04904



Sehr hellblond · Biondo molto chiaro

- » Nicht bleichen
- » Natürliche Implantate 45°

- » Non decolorare
- » Impianto naturale 45°



45 - 50 cm

Ø 54

Sophie

REF. 04903

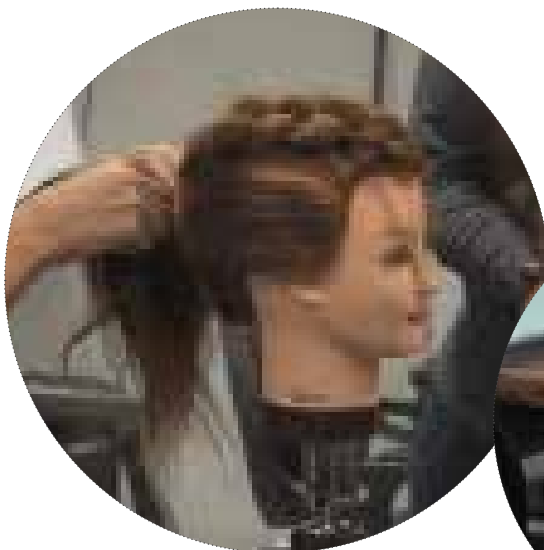

Männliche Schaufensterpuppe, 100% Naturhaar Testa studio uomo, CAPELLI 100% NATURALI

Mit Halterung
Con supporto incluso



- » 42 Implantate pro cm²
- » 7-8 Haare pro Implantat
- » ca. 320 Haare pro cm²
- » Zum Schneiden, Bleichen, Färben, Stylen, Trocknen und Glätten
- » Maximale Temperatur 180°C

- » 42 impianti per cm²
- » 7-8 capelli per impianto
- » 320 capelli circa per cm²
- » Per tagliare, decolorare, tingere, acconciare, asciugatura e piastra
- » Temperatura massima 180°C

Kastanienbraun · Castano

- » Natürliche Implantate 45°

» Impianto naturale 45°



15 - 18 cm

Ø 58

REF. 02495

Kastanienbraun mit Bart · Castano con barba

- » Natürliche Implantate 45°
- » Auch zum Bartschneiden

» Impianto naturale 45°
» Anche per taglio della barba



15 - 18 cm

Ø 58

REF. 02169

Halterung nicht inbegriffen
Supporto non incluso

Kastanienbraun hell JOE · Castano chiaro JOE

- » Natürliche Implantate 45°

» Impianto naturale 45°



15 - 18 cm

Ø 54

REF. 06147

- » Klassisches Implantat 90°

» Impianto classico 90°



15 - 18 cm

Ø 54

REF. 04909

Kastanienbraun hell mit Bart DANIEL · Castano chiaro con barba DANIEL

- » Natürliche Implantate 45°

» Impianto naturale 45°



15 - 18 cm

Ø 54

REF. 06148

- » Klassisches Implantat 90°

» Impianto classico 90°



15 - 18 cm

Ø 54

REF. 04908

Schaufensterpuppen-Kopf, 100% SYNTHETISCHES HAAR
Testa studio, CAPELLI 100% SINTETICI

Halterung nicht inbegriffen
 Supporto non incluso



- » Natürliches Implantat 45°.
- » 42 Implantate pro cm²
- » 5-6 Haare pro Implantat
- » ca. 210 Haare pro cm²
- » Zum Schneiden, Kämmen, Steckfrisuren, Trocknen und Glätten
- » Maximale Temperatur 180°C Bleichen, Färben oder Dauerwelle nicht möglich

- » *Impianto naturale 45°*
- » *42 impianti per cm²*
- » *5-6 capelli per impianto*
- » *210 capelli circa per cm²*
- » *Per tagliare, acconciare, asciugatura e piastra*
- » *Temperatura massima 180°C*
- » *Non adatto a decolorare, tinta o permanente*

Blond · Biondo



35 - 40 cm

REF. 04954

Ø 54



45 - 50 cm

REF. 04955

Ø 54



55 - 60 cm

REF. 04956

Ø 54

Schaufensterpuppen-Kopf, 100% PRO-H SYNTHETISCHES HAAR
Testa studio, CAPELLI SINTETICI 100% PRO-H

Mit Halterung
 Con supporto incluso



- » Zum Schneiden, Färben, Steckfrisuren, Trocknen und Glätten
- » Maximale Temperatur 140°C
- » Nicht färben
- » 42 Implantate pro cm²
- » 6-7 Haare pro Implantat
- » ca. 260 Haare pro cm²
- » Klassisches Implantat 90°
- » Geeignet zum Färben und dauerhaft

- » Per tagliare, tingere, acconciare, asciugatura e piastra
- » Temperatura massima 140°C
- » Non decolorare
- » 42 impianti per cm²
- » 6-7 capelli per impianto
- » 260 peli circa per cm²
- » Impianto classico 90°C
- » Adatto per tinture e permanenti

Hellblond · Biondo chiaro



Ø 50

REF. 02543

10 - 40 cm



Ø 50

REF. 02545

55 - 60 cm



FARBSTOFFE UND DAUERWELLE
 TINTA E PERMANENTE



MAX 140°



Ø 50

REF. 02544

45 - 50 cm

BERGMANN

HAIR AND MORE...

Schaufensterpuppen-Kopf, 100% NATURHAAR Testa studio, CAPELLI 100% NATURALI

Halterung nicht inbegriffen
Supporto non incluso



Hellblond · Biondo chiaro

- » Natürliches Implantat
- » Für Schneiden, Styling, Dauerwelle und Färben

- » *Impianto naturale*
- » *Per tagliare, acconciare, permanente e colore*



Ø 53

30 - 35 cm
aprox.

Junior

REF. 06342

Blond · Biondo

- » Natürliches Implantat
- » Zum Schneiden und Färben

- » *Impianto naturale*
- » *Per tagliare e tingere*



30 - 35 cm
aprox.

Teeny

REF. 06344

Kastanie · Castano

- » Natürliches Implantat
- » Zum Schneiden und Färben

- » *Impianto naturale*
- » *Per tagliare e tingere*



30 - 35 cm
aprox.

Teeny

REF. 06345

Boy

REF. 06341



20 cm
aprox.

Ø 56

Haltegerüst für Trainingsköpfe Supporti per teste studio

» Kunststoff
» Plastica



1 u.m.vta
25 box

REF. 00983

» Kunststoff
» Plastica



1 u.m.vta
25 box

REF. 01461

» Kunststoff
» Plastica



1 u.m.vta
10 box

REF. 06276

» Kunststoff
» Plastica



1 u.m.vta
10 box

REF. 06162

» Aluminium
» Alluminio



1 u.m.vta
12 box

REF. 03625

Stativ Haltegerüst für Trainingsköpfe Supporti a treppiede per teste studio

» Aluminium
» Alluminio

1 u.m.vta
10 box

REF. 03738

» Aluminium
» Alluminio

1 u.m.vta
6 box

REF. 03624

» Aluminium
» Alluminio

1 u.m.vta
6 box

REF. 01841



166 - 81 cm



133 - 65 cm



126 - 78 cm

Möbel

COMPLEMENTI D'ARREDO

*Bedienplatz, Friseurtühle,
Kopfwaschanlagen, Regale, Arbeitswagen...*

Poltrone, lavaggio, mensole, carrelli...



Empfangstheke aus Holz und Metall mit Spiegeleffekt Bancone reception in legno e metallo a effetto specchio

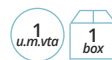

REF.03935

Mit Innenfächern aus Holz zur Aufbewahrung und Ablage
Con scomparti interni in legno



Empfang EARTH Eiche Reception EARTH rovere

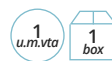

- » Graphit-Laminat
- » Mit verstellbaren Einlegeböden und 1 Schublade

- » Laminato in grafite
- » Con ripiani regolabili e 1 cassetto



REF.04518/50



REF.04518/65



REF.04518/58



REF.04518/72

Bedienplatz Doppelt mit Spiegel
Specchio doppio

- » Mit Schrank, Tisch und Fußstütze
- » Con armadio, mensola e poggiatesta



REF.03949

**Sofa mit 3 Sitzplätzen**
Divano attesa 3 posti

- » In Kunstleder
- » In similpelle



REF.03950

**Bedienplatz MERCURY**
Mobile con specchio a parete MERCURY

Graphit · Grafite ●
REF.04517/50

Weiß · Bianca ○
REF.04517/58

Eiche · Rovere ●
REF.04517/65

Grau · Grigio ●
REF.04517/72



- » Graphit-Laminat
- » Mit Ablage, mit Föhn-Halterung und eingebauter verchromter Fußstütze

- » Laminato in grafite
- » Con mensola, porta-asciugacapelli e poggiatesta integrato cromato

Rechteckiger Spiegel LIGHT
Specchio rettangolare LIGHT

REF.06099



- Rechteckiger Unisex-Spiegel, elegant und raffiniert. Enthält eine große Spiegelfläche. Enthält ein Regal zur Ablage der gewünschten Objekte sowie eine bequeme Fußstütze.

- Specchio rettangolare, elegante e sofisticato. Include un ripiano per appoggiare oggetti, oltre a un comodo poggiatesta..



Stühle für Kinder Poltrone per bambini

Hochwertige Kinderstühle, aus Metall und im Vintage-Stil das Kindern die Erfahrung des Friseurbesuchs angenehm machen soll. Tretautos, die funktionieren, wenn sie aus der Halterung entfernt werden. Dekorative Lichter und Sicherheitsgurt. Wenn Sie das Lenkrad drehen, bewegen sich auch die Vorderräder. Keine Hupe vorhanden.

Poltrone per bambini di alta qualità, realizzate in metallo e con uno stile vintage per rendere piacevole l'esperienza di andare dal parrucchiere ai bambini. Auto a pedali che funzionano se rimosse dal piedistallo. Luci decorative e cintura di sicurezza. Inoltre, se si gira il volante, le ruote anteriori si muovono. Senza clacson.



24 kg

REF.04728



26,8 kg

REF.04727



Spezialstuhl für Kinder Poltrona speciale per bambini



REF.02733



54-79 cm

Kissen speziell für Kinder Cuscini speciali per bambini



Spezielle Kissen, die für jeden Friseurstuhl geeignet sind. Sie ermöglichen dem Fachmann ein bequemerer Arbeiten, da sie das Kind auf die ideale Höhe bringen.

Cuscini speciali adatti a qualsiasi poltrona da parrucchiere. Consentono un lavoro più confortevole per il professionista, poiché sollevano il bambino all'altezza ideale.



REF.04506/50



REF.04506/58



REF.04506/59



REF.04506/60

Kissen speziell für Kinder Cuscini speciali per bambini



REF.07329/50



NEW



REF.04506/69

Kissen speziell für Kinder Cuscini speciali per bambini



REF.03939

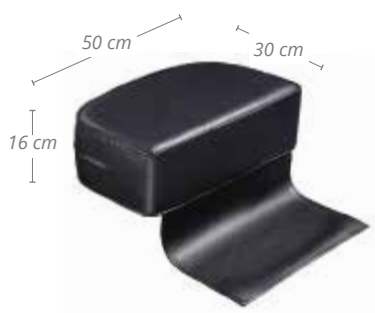

STREET Hocker Sgabello STREET



Der Hocker STREET klassisch enthält eine Hydraulikpumpe, mit der die Höhe auf die gewünschte Höhe des Profis eingestellt werden kann, was ihm die Arbeit erleichtert.

Lo sgabello STREET classico con pompa a gas che permetterà al professionista di regolare l'altezza facilitando il suo lavoro.



REF.06103/50



REF.06103/58

45-59 cm

45 cm

Vergleich 04419 - 06103
Comparativa 04419 - 06103



Hocker mit Metallgestell Sgabello con base in metallo



REF.04419/50

50-66 cm



REF.04419/58

50-66 cm

SWEET SIT Hocker Sgabello SWEET SIT



REF.01328

61-71 cm



RODEO Hocker Sgabello RODEO



REF.01964

58-77 cm



URBAN Hocker

Sgabello URBAN



Ergonomischer Hocker URBAN mit Hydraulikpumpe, um die Höhe bei jeder Arbeit auf die gewünschte Höhe zu regulieren. Seine Form passt sich dem Körper an und begünstigt dadurch eine bessere Körperhaltung und vermeidet Rückenschmerzen nach vielen Arbeitsstunden.

Sgabello URBAN ergonomico con pompa a gas, per regolare l'altezza a quella desiderata per ogni lavoro. La sua forma si adatta al corpo e di conseguenza favorisce una migliore postura e previene il mal di schiena dopo molte ore di lavoro.



REF.06102/50



REF.06102/58

Vergleich 04382 - 06102
Comparativa 04382 - 06102



RODEO Hocker Metallfuß

Sgabello RODEO con base in metallo



REF.04382/50



REF.04382/58

Fußstütze

Poggiapiedi



REF.04384

REF.04385

REF.02838



Gerade Metall-Fußstütze
Poggiapiedi dritto in metallo



Gebogene Metall-Fußstütze
Poggiapiedi curvo in metallo



Stuhl mit Rückenlehne und Regulierung

Poltrona regolabile con schienale



REF.02730/50

REF.02730/58

REF.02730/54

Verstellbarer Stuhl

Poltrona regolabile



REF.02732

REF.02732/58

Stuhl mit Rückenlehne und Regulierung

Poltrona regolabile con schienale

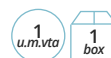

REF.03937/50

REF.03937/58

FASHION Stuhl mit Rückenlehne

Poltrona con schienale FASHION



FASHION Stuhl mit Rückenlehne für mehr Komfort und Rückenunterstützung. Die Räder sind so konstruiert, dass sich die Haare nicht darin verfangen können. Sie sind leicht zu reinigen.

Poltrona FASHION con schienale per un maggiore comfort e sostegno per la schiena. Le ruote sono progettate per evitare che i capelli vi rimangano impigliati, facili da pulire.



REF.06101/58

Kopfwaschanlage GLAMOUR Poltrona lavatesta GLAMOUR

1
u.m.vta

1
box

Neuen Friseurstuhls GLAMOUR. Geradliniges und modernes Design, aber mit maximalem Komfort. Höhenverstellbar Dank seiner Hydraulikpumpe.

REF.07191

Nuova poltrona lavatesta per parrucchieri/barbieri GLAMOUR. Design lineare e moderno, con la massima comodità. Vasca basculante in ceramica, ergonomica.

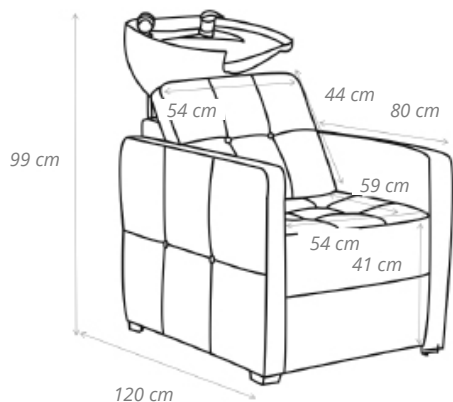

NEW

Kopfwaschanlage KURVA Poltrona lavatesta KURVA

1
u.m.vta

1
box

Neuen Friseurstuhls KURVA. Geradliniges und modernes Design, aber mit maximalem Komfort. Ausgestattet mit einem ergonomischen und neigbarem Keramikbecken.

REF.07193

Nuova poltrona lavatesta per parrucchieri/barbieri KURVA. Design lineare e moderno, con la massima comodità. Vasca basculante in ceramica, ergonomica.

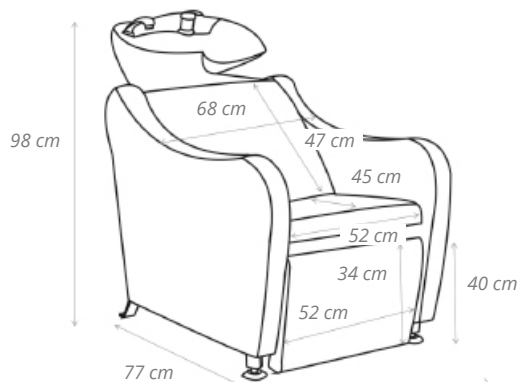

NEW

Kopfwaschanlage OVAL Poltrona lavatesta OVAL

1 u.m.vta
1 box

Neuen Friseurstuhls OVAL. Geradliniges und modernes Design, aber mit maximalem Komfort. Ausgestattet mit einem ergonomischen und neigbarem Keramikbecken.

REF.07195

Nuova poltrona lavatesta per parrucchieri/barbieri OVAL. Design lineare e moderno, con la massima comodità. Vasca basculante in ceramica, ergonomica.

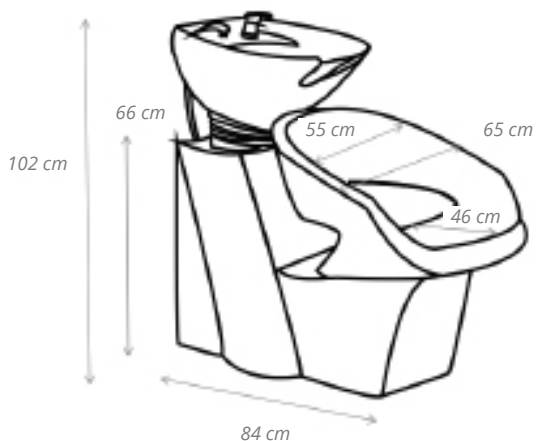

NEW

Kopfwaschanlage KVADRAT Poltrona lavatesta KVADRAT

1 u.m.vta
1 box

Neuen Friseurstuhls KVADRAT. Geradliniges und modernes Design, aber mit maximalem Komfort. Höhenverstellbar Dank seiner Hydraulikpumpe.

REF.07197

Nuova poltrona lavatesta per parrucchieri/barbieri KVADRAT. Design lineare e moderno, con la massima comodità. Vasca basculante in ceramica, ergonomica.

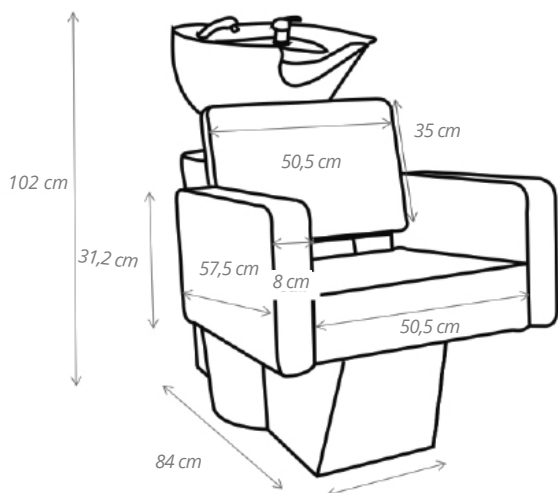

NEW

Kopfwaschanlage PIN UP
Poltrona lavatesta PIN UP

Aufgrund der Schaumstoffpolsterung können die Maße eine kleine Abweichung von etwa 1 cm aufweisen.

REF.06476/70

A causa della schiuma nell'imbottitura, le misure possono subire una leggera variazione di circa 1 cm.

**Kopfwaschanlage STIL**
Poltrona lavatesta STIL

- » Armlehnen und Bedienelemente aus Chrom
- » Keramikfliese und Glasfasersockel
- » Schiebesitz
- » Basislänge 76 cm
- » Sitzbreite 48 cm
- » Höhe der Rückenlehne 41 cm
- » Keramikbecken 57 x 50 x 20 cm
- » Gesamthöhe 95 cm

- » Bracciali e rubinetto cromati
- » Lavello in ceramica e base in fibra di vetro
- » Sedile scorrevole
- » Lunghezza base 76 cm
- » Larghezza sedile 48 cm
- » Altezza schienale 41 cm
- » Lavabo in ceramica 57 x 50 x 20 cm
- » Altezza totale 95 cm



REF. 02841



REF. 02841/54



REF. 02841/58

Kopfwaschanlage NEPTUNO Poltrona lavatesta NETTUNO

1 u.m.vta 1 box

- » Stahl- und Holzkonstruktion
- » Weißes kippbares Keramikbecken
- » Fester Sitz
- » Einhebelmischer mit schwarzer Handbrause

- » *Struttura in acciaio e legno*
- » *Vasca basculante in ceramica bianca*
- » *Sedile fisso*
- » *Miscelatore doccia nero*



REF.04516/50 REF.04516/58 REF.04516/60

REF.04516/62 REF.04516/64 REF.04516/65

REF.04516/68 REF.04516/69 REF.04516/72

Kopfwaschanlage VENUS Poltrona lavatesta VENUS

1 u.m.vta 1 box

- » Struktur aus Polyethylen
- » Weißes kippbares Keramikbecken
- » Fester Sitz
- » Einhebelmischer mit schwarzer Handbrause

- » *Struttura in polietilene*
- » *Vasca basculante in ceramica bianca*
- » *Sedile fisso*
- » *Miscelatore doccia nero*



REF.04514/50 REF.04514/58 REF.04514/60

REF.04514/62 REF.04514/64 REF.04514/65

REF.04514/68 REF.04514/69 REF.04514/72

Kopfwaschanlage VENUS--Trennwand schwarz Separatore lavatesta VENUS nero

1 u.m.vta 1 box



REF.04515

Kopfwaschanlage ART Poltrona lavatesta ART

1
u.m.vta

1
box

Die neue ART-Kopfwaschanlage hat ein Design mit geschwungenen Linien, in den Ausführungen Schwarz und Silber, das dem Kunden maximalen Komfort beim Haarewaschen bietet. Sie besteht aus einem tiefen, ergonomisch geformten Keramikbecken, der sich im Beinbereich verstellen und an jeden Service anpassen lässt. Zusammen mit dem ART-Stuhl bilden sie das ideale Set für Ihren Salon.

La nuova poltrona lavatesta ART ha un design dalle linee curve, di colore nero e con finiture argento, pensato per offrire il massimo comfort al cliente durante il lavaggio dei capelli. E' composta da un lavabo in ceramica profondo, ergonomico, reclinabile nella zona dei piedi.

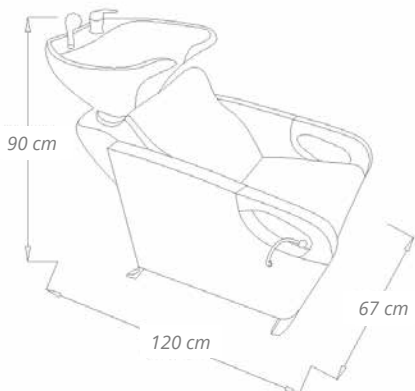

REF.06097/50

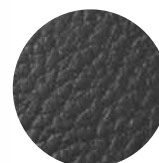

Verstellbar
Reclinabile



Kopfwaschanlage MOOD

Poltrona lavatesta MOOD

1
u.m.vta

1
box

Die neue MOOD-Kopfwaschanlagen hat ein Design mit geschwungenen Linien, das dem Kunden maximalen Komfort beim Haarewaschen bieten soll. Sie besteht aus einem tiefen, ergonomisch geformten Keramikbecken, der im Beinbereich verstellbar und an jeden Dienst angepasst werden kann.

La nuova poltrona lavatesta MOOD ha un design dalle linee curve pensato per offrire il massimo comfort al cliente durante il lavaggio dei capelli. È composta da un lavello in ceramica profondo, ergonomico, reclinabile nella zona dei piedi e adattabile a ogni servizio.

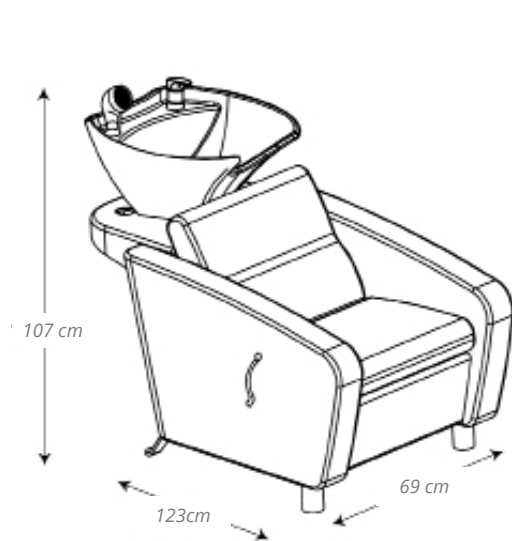

REF.06098/50

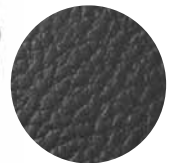

Verstellbar
Reclinabile



Friseurstuhl GLAMOUR

Poltrona da parrucchiere GLAMOUR

1
u.m.vta

1
box

REF.07190

Vielen Dank für den Kauf unseres neuen Friseurstuhls GLAMOUR. Geradliniges und modernes Design, aber mit maximalem Komfort. Höhenverstellbar Dank seiner Hydraulikpumpe.

NEW

Nuova poltrona per parrucchieri/barbieri GLAMOUR. Design lineare e moderno, con la massima comodità. Altezza regolabile.

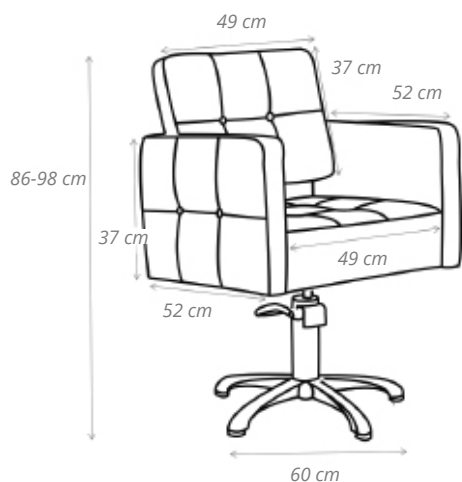

Friseurstuhl KURVA

Poltrona da parrucchiere KURVA

1
u.m.vta

1
box

REF.07192

Vielen Dank für den Kauf unseres neuen Friseurstuhls KURVA. Geradliniges und modernes Design, aber mit maximalem Komfort. Höhenverstellbar Dank seiner Hydraulikpumpe.

NEW

Nuova poltrona per parrucchieri/barbieri KURVA. Design lineare e moderno, con la massima comodità. Altezza regolabile.

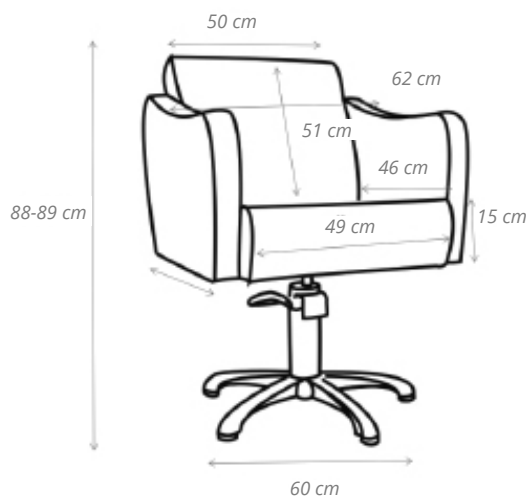

Friseurstuhl OVAL

Poltrona da parrucchiere OVAL

1 u.m.vta
1 box

REF.07194

Vielen Dank für den Kauf unseres neuen Friseurstuhls OVAL. Geradliniges und modernes Design, aber mit maximalem Komfort. Höhenverstellbar Dank seiner Hydraulikpumpe.

Nuova poltrona per parrucchieri/barbieri OVAL. Design lineare e moderno, con la massima comodità. Altezza regolabile.

NEW

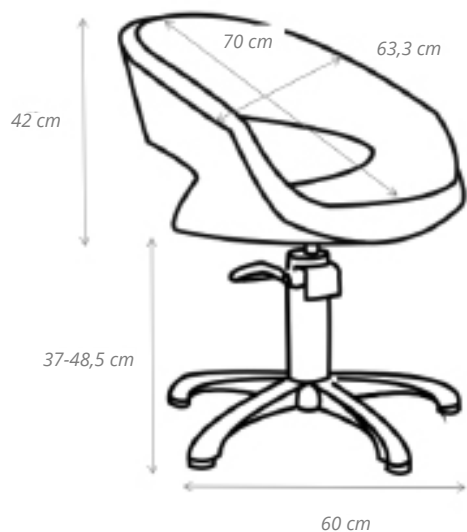

Friseurstuhl KVADRAT

Poltrona da parrucchiere KVADRAT

1 u.m.vta
1 box

REF.07196

Vielen Dank für den Kauf unseres neuen Friseurstuhls KVADRAT. Geradliniges und modernes Design, aber mit maximalem Komfort. Höhenverstellbar Dank seiner Hydraulikpumpe.

Nuova poltrona per parrucchieri/barbieri KVADRAT Design lineare e moderno, con la massima comodità. Altezza regolabile.

NEW

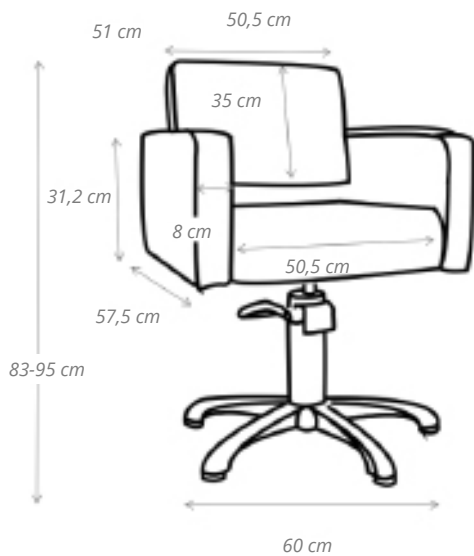

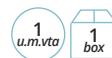
Friseurstuhl COMFORT**Poltrona da parrucchiere COMFORT**

Der Friseurstuhl COMFORT hat ein Design mit geraden Linien, das für maximalen Komfort sorgt. Der Stuhl verfügt über eine Hydraulikpumpe, mit der Sie den Sitz heben und senken können, so dass Sie den Kunden auf die Höhe bringen können, die für die jeweilige Arbeit am besten geeignet ist.

La poltrona da parrucchiere COMFORT ha un design dalle linee dritte studiato per offrire il massimo del comfort. Altezza regolabile.

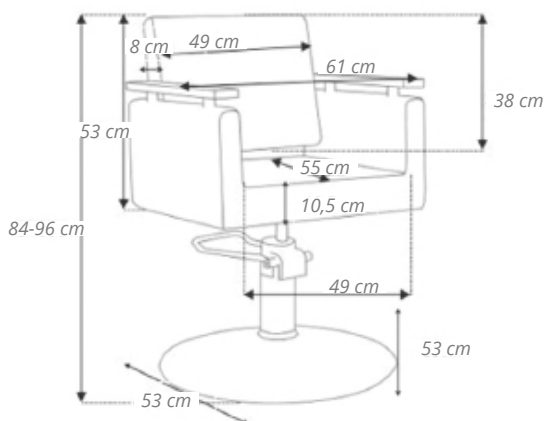

REF.06585

Sternfuß
Piedistallo a stella

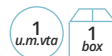
Friseurstuhl PIN UP ROSE**Poltrona da parrucchiere PIN UP ROSA**

Der neue PIN UP Stuhl hat ein Design mit modernen Linien, die auf maximalen Komfort ausgelegt sind. Der Stuhl verfügt über eine Hydraulikpumpe, mit der der Sitz angehoben und abgesenkt werden kann, so dass Sie den Kunden auf die Höhe bringen können, die für die jeweilige Arbeit am besten geeignet ist.

La nuova poltrona PIN UP ha un design dalle linee moderne studiato per offrire il massimo del comfort. Altezza regolabile.

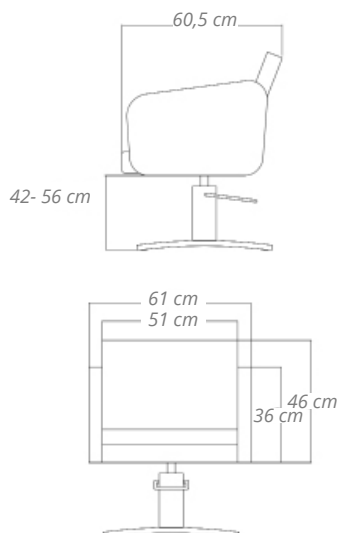

REF.06477/70

Friseurstuhl STRATOS

Poltrona STRATOS

- » Mit Fußstütze
- » Hydraulischer Höhenverstellung
- » Rückenlehne: 52 x 45 cm
- » Breite Armlehne zu Armlehne: 50 cm
- » Sitzbasis: 48 cm
- » Verchromte Armstützen

- » Con poggiatesta
- » Altezza regolabile
- » Schienale: 52 x 45 cm
- » Larghezza da bracciolo a bracciolo: 50 cm
- » Base del sedile: 48 cm
- » Braccioli cromati



REF. 02840



REF.02840/54



REF.02840/60



REF.02840/59

Hydraulischer Friseurstuhl VENUS SCHWARZ

Poltrona VENUS BLACK

- » Unterlage mit Sternemotiven aus Aluminium
- » Hydraulisches Anheben
- » In Schwarz gepolstert
- » Breite: 58 cm
- » Tiefe: 64 cm
- » Hubhöhe Sitz: 45 cm – 60,5 cm

- » Base a stella in alluminio
- » Sollevamento idraulico
- » Rivestimento in nero
- » Larghezza: 58 cm
- » Profondità: 64 cm
- » Altezza di elevazione del sedile: 45 cm - 60,5 cm



REF.04513/50

REF.04513/58

REF.04513/60

REF.04513/62

REF.04513/64

REF.04513/65



REF. 04513/68

REF.04513/69

REF.04513/72

Friseurstuhl CHIC**Poltrona da parrucchiere CHIC**

Der Friseurstuhl CHIC hat ein klassisches Design, das gerade und geschwungene Linien kombiniert und für maximalen Komfort sorgt. Der Stuhl verfügt über eine Hydraulikpumpe, mit der der Sitz angehoben und abgesenkt werden kann, so dass der Kunde in der Höhe positioniert werden kann, die für die jeweilige Arbeit am besten geeignet ist. Es kann mit 3 Füßen und mit der Option einer Fußstütze kombiniert werden.

La poltrona da parrucchiere CHIC ha un design classico che combina linee dritte e curve studiato per offrire il massimo del comfort. Altezza regolabile. Abbinabile a 3 piedistalli e con possibilità di poggiatesta.

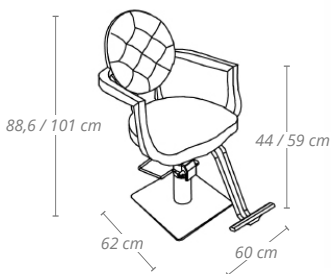

REF.06096/50/2 REF.06096/50/5*



REF.06096/50/3 REF.06096/50/6*



REF.06096/50/1 REF.06096/50/4*



* Mit Fußstütze
*Con poggiatesta

Friseurstuhl STYLE**Poltrona da parrucchiere STYLE**

Der Friseurstuhl STYLE hat ein Vintage-Design, das geschwungene Linien in Schwarz und mit weißen Nähten kombiniert, um maximalen Komfort zu bieten. Der Stuhl verfügt über eine Hydraulikpumpe, mit der der Sitz angehoben und abgesenkt werden kann, so dass Sie den Kunden in der Höhe platzieren können, die für die jeweilige Aufgabe am besten geeignet ist. Es kann mit 3 Füßen und mit der Option einer Fußstütze kombiniert werden.

La poltrona da parrucchiere STYLE ha un design vintage che combina linee curve, in nero e cuciture bianche, pensato per offrire il massimo comfort. Altezza regolabile. Abbinabile a 3 piedistalli e con possibilità di poggiatesta.

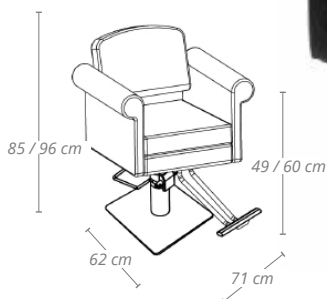

REF.06095/50/2 REF.06095/50/5*



REF.06095/50/3 REF.06095/50/6*



REF.06095/50/1 REF.06095/50/4*



* Mit Fußstütze
*Con poggiatesta

Friseurstuhl BOHEMIAN

Poltrona da parrucchiere BOHEMIAN



Der Friseurstuhl BOHEMIAN hat ein modernes Design, das geschwungene und gerade Linien kombiniert, in Schwarz und mit silbernen Oberflächen, um maximalen Komfort zu bieten. Der Stuhl verfügt über eine Hydraulikpumpe, so dass Sie den Sitz heben und senken und den Kunden auf die Höhe bringen können, die für die jeweilige Arbeit am besten geeignet ist. Es kann mit 3 Füßen und mit der Option einer Fußstütze kombiniert werden.

La poltrona da parrucchiere BOHEMIAN ha un design contemporaneo che combina linee curve e dritte, in nero e finiture argento, pensato per offrire il massimo comfort. Altezza regolabil. Abbinabile a 3 piedistalli e con possibilità di poggiapiedi.



REF.06093/50/2 REF.06093/50/5*



REF.06093/50/3 REF.06093/50/6*

REF.06093/50/1 REF.06093/50/4*

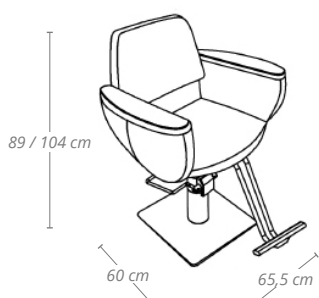

* Mit Fußstütze
*Con poggiapiedi

Friseurstuhl ART

Poltrona da parrucchiere ART



Der Friseurstuhl ART hat ein modernes Design, das geschwungene Linien, schwarze Farbe und silberne Oberflächen kombiniert, um maximalen Komfort zu bieten. Der Stuhl verfügt über eine Hydraulikpumpe, mit der Sie den Sitz heben und senken können, so dass Sie den Kunden auf die Höhe bringen können, die für die jeweilige Arbeit am besten geeignet ist. Es kann mit 3 Füßen und mit der Option einer Fußstütze kombiniert werden.

La poltrona da parrucchiere ART ha un design moderno che combina linee curve in nero e finiture argento pensato per offrire il massimo comfort. Altezza regolabil. Abbinabile a 3 piedistalli e con possibilità di poggiapiedi.



REF.06094/50/2 REF.06094/50/5*



REF.06094/50/3 REF.06094/50/6*

REF.06094/50/1 REF.06094/50/4*

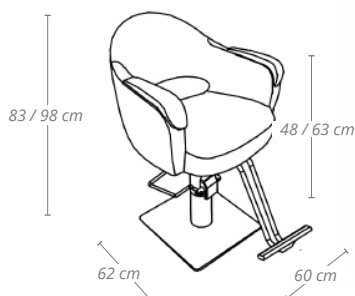

* Mit Fußstütze
*Con poggiapiedi

Tragbare aufblasbare Kopfwaschanlage Lavatesta portatile gonfiabile



1 u.m.vta
20 box

REF.03923

Tragbare Kopfwaschanlage Lavatesta portatile

1 u.m.vta
12 box



REF. 04838/50

REF. 04838/70

REF. 04838/54

Tragbare Kopfwaschanlage mit Fuß und Ablauf Lavatesta portatile con piedistallo e scarico



1 u.m.vta
15 box

REF. 03736



* Detail unterstützt Shampoos
* Il dettaglio supporta gli shampoo

Tragbare Kopfwaschanlage Poltrona lavatesta portatile

1 u.m.vta
1 box

REF.01970



» Höhenverstellbarer Fuß
» Ablauf: 50 cm
» Nicht kippsicher

» Piedistallo regulabile in altezza
» Scarico: 50 cm
» Non basculante



REF. 03736/68

» Mit Fuß und Ablauf.
» Mit Platz für Shampoos.
» Kippbar.



REF. 03736/54

» Con piedistallo e scarico.
» Con foro per shampoo.
» Basculante.

Spülbehälter Ø 45- 21 cm Deposito lavatesta Ø 45-21 cm

1 u.m.vta
5 box

250 ml

REF.03737



Geeignet für diese Modelle
Adatto a questi modelli



REF. 03736



REF. 01970

Tragbares Kopfwaschbrett mit Rückenstütze für Stühle Lavatesta portatile con sostegno per poltrone

2
u.m.vta

2
box



Kopfwaschanlage, bestehend aus einer Brett aus sehr leichtem Material, leicht zu montieren, in der Höhe verstellbar und sehr praktisch, um die Haarhygiene für Personen mit geringer Mobilität oder für Hausdienste durchzuführen.

Lavatesta composto da un lavello in materiale molto leggero, facile da montare, regolabile in altezza e molto pratico per eseguire l'igiene dei capelli a persone con poca mobilità o per servizi a domicilio.

REF.06952

REF.06952/00

1
u.m.vta

1
box

Tragbares Eurostil-Kopfwaschbrett mit Befestigung an Rückenlehnen
Lavatesta Eurostil con gancio per schienale

Tragbares Kopfwaschbrett mit Rückenlehnenbefestigung. No Name
Lavatesta portatile con gancio per schienale. Anonimo



REF.RE06952/04



REF.RE06952/04/00

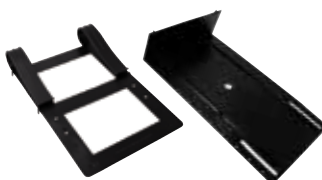

REF.RE06952/05



Schachtel mit 2
Waschbretter Eurostil
Confezione da 2
Eurostil

Schachtel mit 2
Waschbretter No Name
Confezione 2
Senza nome

Schachtel mit 2
Befestigungen für
Rückenlehnen
Confezione 2 ganci per
schienale

Mobiler Rolltisch Carrello ausiliario

1
u.m.vta

1
box

Gio

REF.02366/50

Jolly

REF.00874

Black

REF.03215



Verstellbarer Beistelltisch
Carrello ausiliario regolabile

REF.03843

» Mit Edelstahlfuß

» Con pianale in acciaio
inossidabile**Beistelltisch mit 2 Färbfächern**
Carrello 2 vassoio per colore

REF.03181

- » Spezialwagen für alle Arten von Färbe- und Bleicharbeiten
- » Mit Fassungsvermögen für mehrere Farbrührer, Schalen und einem speziellen Halter für die benötigte Aluminiumfolie für Strähnen.
- » Leicht und sehr handlich
- » Mit leicht lenkbaren Schwenkrollen

- » Carrello speciale per tutti i tipi di lavori di colore e decolorazione
- » Con capacità per diversi shaker, ciotole e una speciale sistemazione per i fogli di alluminio necessari per le meches
- » Leggero e molto maneggevole
- » Con ruote girevoli per un miglior movimento



SWING Holzarbeitswagen Carrello SWING



Wagen mit zwei schwarzen Körpern bzw. 3 Schubladen (insgesamt 6) Er verfügt über 4 Räder, um beim Transport komfortabler zu sein. Die obere Ablage hat viel Platz und enthält mehrere Löcher, in denen verschiedene Objekte abgelegt werden können. Er beinhaltet auch einen Metallhalter zur Ablage eines Haartrockners.

Carrello con due blocchi neri e 3 scomparti rispettivamente (6 in totale). Con 4 ruote per essere più comodo durante lo spostamento. Il vassoio superiore ha molto spazio e presenta vari fori pensati per sistemare oggetti diversi. Include anche un gancio in metallo per sostenere l'asciugapelli.



REF.06279

Arbeitswagen zum Färben Carrello per colore



- » Spezieller Arbeitswagen für alle Arten von Färbe- und Bleicharbeiten
- » Mit Kapazität für mehrere Farbpinsel, Rührbehälter, Schalen und zwei spezielle Unterbringungsmöglichkeiten für die Aluminiumfolie
- » Leicht und sehr handlich
- » Mit leicht lenkbaren Schwenkrollen

- » Carrello speciale per tutti i tipi di lavori di colore e decolorazione
- » Con capacità per varie palette, shaker, ciotole e due alloggi speciali per la sistemazione dei fogli di alluminio necessari per le meches
- » Leggero e molto maneggevole
- » Con ruote girevoli per un miglior movimento



REF.03180

MASTER UP Friseur-Arbeitswagen Carrello per parrucchiere MASTER UP



REF.01963/50

ZEPHIR Holzarbeitswagen Carrello in legno ZEPHIR



REF.01331

Friseur-Arbeitswagen Carrello per parrucchiere

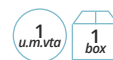

Mod. Boy

REF.00877

Mod. Smile

REF.04380

Mod.Funny

REF.04381



Friseur-Arbeitswagen Carrello per parrucchiere

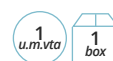

- » Arbeitswagen mit 6 herausnehmbaren und austauschbaren Schubladen
- » Mit Platz für Tuben, Schalen und Haartrockner
- » Werkstoff Polypropylen

- » Carrello ausiliario con 6 scomparti estraibili e intercambiabili
- » Con spazio indicato per mettere oggetti, ciotole e asciugacapelli
- » Materiale in polipropilene

REF.04276/50



Handbrause mit Anschluss
Doccia con supporto

1 u.m.vta
20 box

REF.03004



Aufsatz Dusch-Set
Set doccia adattabile

1 u.m.vta
10 box

REF.01960



Einhandmischer für Waschbecken
Miscelatore per lavatesta

1 u.m.vta
50 box

REF.02837



Ionischer Duschkopf
Soffione doccia ionico

1 u.m.vta
36 box

REF.03750



Spart Wasser Bessere
Wasserqualität

Risparmio idrico Migliore
qualità dell'acqua

Handtuchhalter
Organizer per appendere asciugamani

1 u.m.vta
6 box

REF.04378

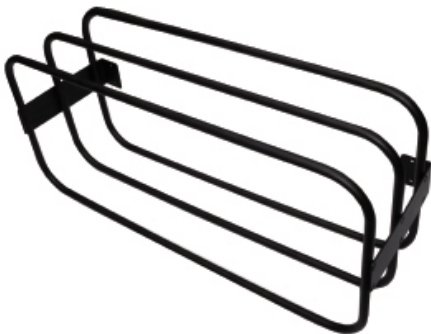

Handtuch-Container
Porta asciugamani

1 u.m.vta
4 box

REF.03159



» Mit Rädern
» Waschbarer
Container-Beutel
» Struktur aus
rostfreiem Stahl

» Con ruote
» Borsa contenitore
lavabile
» Struttura in acciaio
inox

08

Kämme und bürsten

PETTINI
E SPAZZOLE

*Bürsten, Thermobürsten,
Kämme, Friseurkoffer, Austeller...*

*Spazzole, spazzole termiche, pettini,
astucci per parrucchieri, espositori...*



Toupierbürsten

Spazzole per cotonare

- » Naturborsten
- » Setole in nylon



REF.00105/50

- » Naturborsten
- » Setole di cinghiale



REF.02452

- » Naturborsten
- » Setole di cinghiale



REF.04528

3 Bürstenreihen, die höchste Reihe in der Mitte
3 file di setole, la fila centrale più alta

- » Naturborsten
- » Setole in nylon



REF.00106



REF.00106/58

- » Naturborsten
- » Setole di cinghiale



REF.03171



REF.03171/58

- » Kunststoffbündel
- » Punte in plastica



REF.03880



REF.03880/58

- » Naturborsten
- » Setole di cinghiale



REF.03227

Hölzerne Bürste. Gebogener Form für bessere Handhabung
Spazzole in legno. Corpo ricurvo per un migliore adattamento

- » Gummibürsten mit Stahlstiften + Kugeln
- » Punte in metallo con sfera



REF.00161

Spiralbürsten mit Kunststoffgriff

Spazzole a spirale con manico in plastica



1 u.m.vta
50 box

REF. 01851



NYLON



1 u.m.vta
40 box

REF. 01598



NYLON



» Naturborsten
» Setole di cinghiale

1 u.m.vta
12 box

REF. 02995



Spiralbürsten mit Holzgriff

Spazzole a spirale con manico in legno

1 u.m.vta
72 box

REF. 00351



NYLON



1 u.m.vta
30 box

REF. 00502



NYLON



1 u.m.vta
30 box

REF. 01597



NYLON



Rundholzbürste Spazzole in legno



NYLON

» Nylonbündel
» Setole in nylon

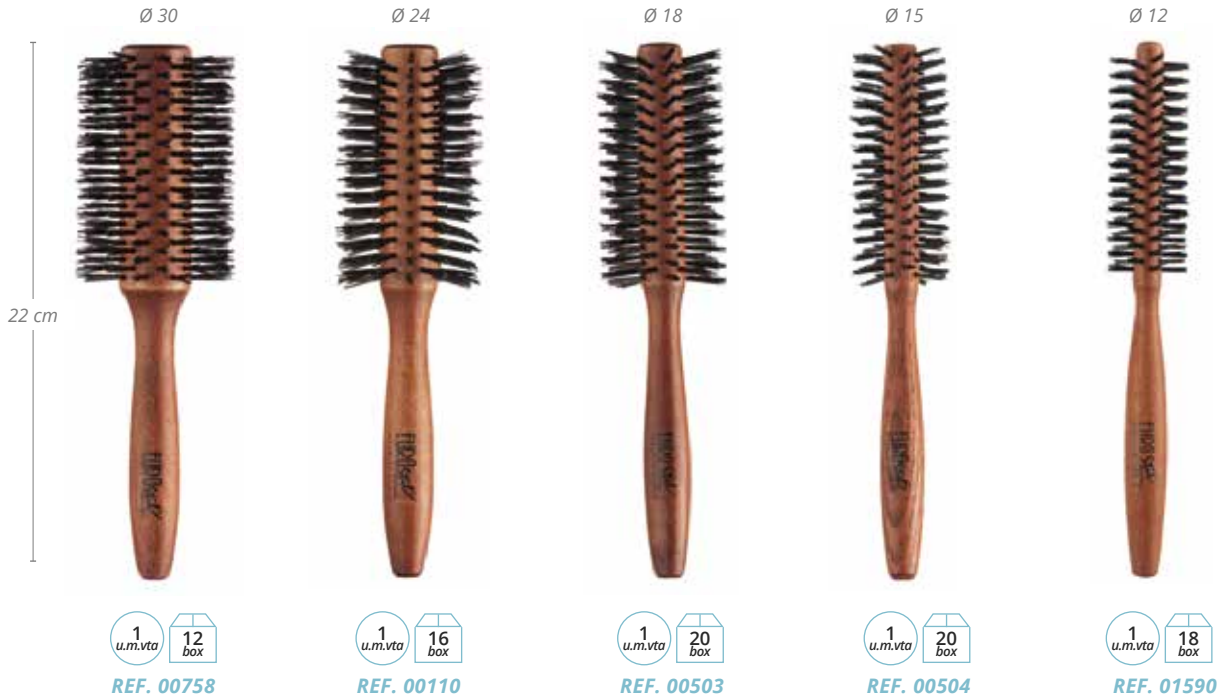

JUMBO Kunststoff-Rundbürste Spazzole in plastica JUMBO



NYLON



» Nylonbündel
» Setole in nylon

REF. 02178



Rundholzbürste

Spazzole in legno



» Nylonbündel und Naturborsten
» Setole in nylon + cinghiale



» Lange Borsten
» Setole lunghe

» Kurze Borsten
» Short bristles

Rundholzbürste Spazzole in legno



- » Nylonbündel+Kugeln
- » Setole in nylon + punta arrotondata



Rundholzbürste Spazzole in legno



- » Naturborsten
- » Setole di cinghiale

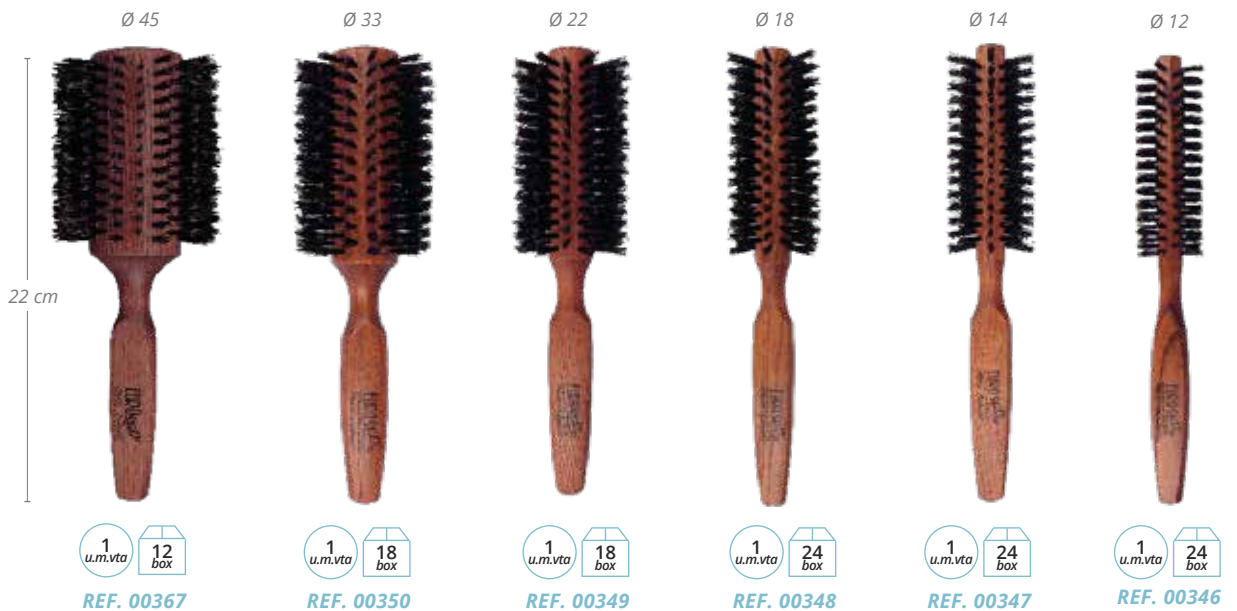

Rundholzbürste mit Gummigriff

Spazzole in legno con manico in gomma



» Nylonbündel und Naturborsten
» Setole di nylon + cinghiale

Ø 38



1 u.m.vta
12 box

REF. 03130

Ø 30



1 u.m.vta
12 box

REF. 03129

Ø 24



1 u.m.vta
12 box

REF. 03128

Ø 18



1 u.m.vta
16 box

REF. 03127

Ø 15



1 u.m.vta
16 box

REF. 03126

22 cm



Gummibürsten mit Holzgriff

Spazzole pneumatiche con manico in legno



» Naturborsten
» Setole di cinghiale



REF. 00328



REF. 00327



REF. 00352



REF. 00326



REF. 00325

Gummibürsten mit Holzgriff

Spazzole pneumatiche con manico in legno



» Nylonbündel und Naturborsten
» Setole di nylon + cinghiale



REF. 00528



REF. 00529

Gummibürsten mit Holzgriff

Spazzole pneumatiche con manico in legno

- PLASTIC
» Kunststoffbündel
» Punte in plastica



REF. 00590



REF.00597



REF. 01994



REF.03298



REF.03299

- » Komfortable Bürste
- » Leicht zu entwirren
- » Ergonomisch und leicht
- » Klassisch und elegant

- » Spazzole comoda
- » Districa facilmente
- » Ergonomica e leggera
- » Classica ed elegante

Holzaussteller 20 Bürsten

Espositore in legno 20 spazzole



REF.03387



Gummibürsten mit Holzgriff

Spazzole pneumatiche con manico in legno



METAL

- » Stahlstiften mit Kugeln
- » Setole in metallo, con punte arrotondate



REF. 00146



REF. 00148



REF. 00147

Bambusbürsten

Spazzole di bambù



WOOD



- » Bürstenkörper und Borsten aus natürlichem Bambusholz
- » Kontrollierte Holzproduktion
- » Antistatische Bürste
- » Verleiht dem Haar Glanz und Geschmeidigkeit
- » Sehr widerstandsfähiges und flexibles Holz

- » Corpo della Spazzole e punte in legno di bambù naturale
- » Produzione controllata del legno
- » Spazzole antistatica
- » Dona lucentezza e morbidezza ai capelli
- » Legno molto resistente e flessibile



REF. 03223



REF. 03224



REF. 03225



REF. 03226

Gummibürsten mit Holzgriff

Spazzole pneumatiche con manico in legno



- WOOD
» Holzstiften
» Setole in legno



REF. 01922



REF. 01921



REF. 01920



REF. 01919

Gummibürsten mit Holzgriff

Spazzole pneumatiche con manico in legno

- NYLON
» Nylonbündel
» Setole in nylon



1 u.m.vta
70 box

REF. 01924

Groß
Big



1 u.m.vta
50 box

REF. 01923

Wenig
Small



Rechteckige Gummibürsten

Spazzole pneumatica a paletta rettangolare

- PLASTIC
» Kunststoffbündel
» Holz



- » Setole in plastica
» Legno

REF. 02463/99



Gummibürsten mit Holzgriff

Spazzole pneumatiche, districanti



PLASTIC

- » Kunststoffbündel mit kugeln
- » Setole in plastica, con punte arrotondate



REF. 04282



REF. 04281



REF. 04280



REF. 04279



Gummibürsten mit Holzgriff

Spazzole pneumatiche con manico in plastica



» Naturborsten oder Nylon
» Setole di cinghiale e nylon



REF. 03691



REF. 03690



REF. 03693



REF. 03689

Bürste mit kunststoffgriff

Spazzole pneumatiche con manico in plastica



» Naturborsten oder Nylon
» Setole di cinghiale e nylon



REF. 01472



REF. 01471

Gummibürsten und Kunststoffgriff

Spazzole pneumatiche con manico in plastica



- » Naturborsten
- » Setole di cinghiale

PLASTIC

- » Kunststoffbündel
- » Setole in plastica

PLASTIC

- » Kunststoffbündel mit Kugeln
- » Setole in plastica, con punte arrotondate



1 u.m.vta
12 box

REF. 00767



1 u.m.vta
12 box

REF. 00793



1 u.m.vta
24 box

REF. 00755

Ovale Profi-Bürste

Spazzola pneumatica ovale professionale



1 u.m.vta

18 box

REF. 00337

PLASTIC

- » Kunststoffbündel mit Kugeln
- » Setole in plastica, con punte arrotondate

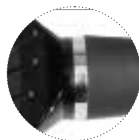

Gummibürsten mit Holzgriff

Spazzole pneumatiche con manico in legno



METAL

- » Stahlstiften mit Kugeln
- » Setole di metallo, con punte arrotondate

1 u.m.vta
36 box
S

REF. 00158/50



REF. 00158



1 u.m.vta
24 box
M

REF. 00159/50



REF. 00159



1 u.m.vta
24 box
L

REF. 00160/50



REF. 00160



Gummibürsten mit Holzgriff

Spazzole pneumatiche con manico in plastica



METAL

- » Stahlstiften mit Kugeln
- » Antistatische Bürste

- » Setole in plastica con punte arrotondate
- » Spazzole antistatica

1 u.m.vta
12 box
REF. 00587



1 u.m.vta
12 box
REF. 00586



Gummibürsten mit Holzgriff

Spazzole pneumatiche con manico in plastica



» Nylonbündel
» Setole in nylon



Gummibürsten mit Holzgriff

Spazzole pneumatiche con manico in plastica



» Nylonbündel mit Kugeln
» Setole in nylon con punte arrotondate



Gummibürsten mit Holzgriff

Spazzole pneumatiche con manico in plastica



- » Naturborsten
- » Setole di cinghiale



1 u.m.vta
12 box
S

REF. 00303



1 u.m.vta
12 box
M

REF. 00304



1 u.m.vta
12 box
L

REF. 00305

Gummibürsten mit Holzgriff

Spazzole pneumatiche con manico in plastica



- » Kunststoffbündel
- » Punte in plastica

- » Kunststoffbündel mit Kugeln
- » Setole in plastica con punte arrotondate

- » Kunststoffbündel mit Kugeln
- » Setole in plastica con punte arrotondate

- » Kunststoffbündel mit Kugeln
- » Setole in plastica con punte arrotondate



1 u.m.vta
18 box

REF.00309



1 u.m.vta
24 box

REF. 00155/50



1 u.m.vta
24 box

REF. 00156/50



1 u.m.vta
36 box

REF. 00157/50

Gummibürsten mit kunststoffgriff
Spazzole pneumatiche con manico in plastica



» Nylonbündel
 » Setole in nylon



» Naturborsten
 » Setole di cinghiale

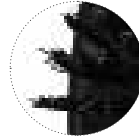

REF. 03091



REF. 03088



REF. 03092



REF. 03089

Gummibürsten mit Kunststoffgriff
Spazzole pneumatiche con manico in plastica



» Kunststoffbündel mit Kugeln
 » Setole in plastica con punte arrotondate



REF. 03093



REF. 03090

Gummibürsten mit Gummigriff

Spazzole pneumatiche con manico in gomma



PLASTIC

» Kunststoffbündel mit Kugeln

» Setole in plastica con punte arrotondate

1
u.m.vta12
box

S

REF. 03101

1
u.m.vta12
box

M

REF. 03098

1
u.m.vta6
box

L

REF. 03103

Gummibürsten mit Gummigriff

Spazzole pneumatiche con manico in gomma



» Naturborsten

» Setole di cinghiale

1
u.m.vta12
box

S

REF. 03100

1
u.m.vta12
box

M

REF. 03308

1
u.m.vta6
box

L

REF. 03102

Skelettbürste mit Gummigriff

Spazzole pneumatiche con manico in gomma



NYLON

- » Nylonbündel
- » Setole in nylon



1
u.m.vta

12
box

REF. 03309



1
u.m.vta

12
box

REF. 03099

Skelettbürste mit Gummigriff

Spazzole scheletro con manico in gomma

PLASTIC

- » Kunststoffbündel mit Kugeln
- » Setole in plastica con punte arrotondate

1
u.m.vta

12
box



S

REF. 03095



L

REF. 03094

Thermische Bürsten

Spazzole termiche

- » Auch erhältlich: Thermobürsten aus zwei Materialien

» Sono disponibili anche spazzole termiche bimatereiale

PÁG.236



REF. 03349



REF. 03348



REF. 03347



REF. 03346

Gummibürsten Spazzole pneumatiche



PLASTIC

- » Kunststoffbündel mit Kugeln
- » Setole in plastica con punte arrotondate

REF.03202



Bürsten mit einer Gummiplatte, die sich perfekt an die Form des Kopfes anpassen und einen breiten und weichen Bürsteeffekt erzielen. Kunststoffborsten mit kugelförmiger Oberfläche in der Farbe der Bürste. Komfortabler und benutzerfreundlicher Griff.

Spazzole pneumatiche che si adattano perfettamente alla forma della testa fornendo un effetto Spazzoletura ampio e morbido. Punte in plastica con finitura a sfera dello stesso colore della Spazzole. Manico comodo e piacevole da usare.



Entwirrende Bürste

Spazzole districanti



REF. 03881

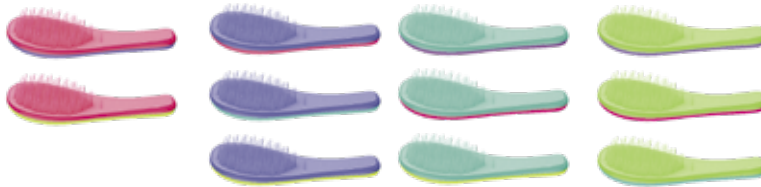

- » 3 Borstenhöhen: 120 kleine Borsten, 123 mittlere Borsten, 119 lange Borsten
- » Ergonomischer Griff
- » Flexibel und glatt, aber effizient
- » Hochwertiges Thermoplast
- » Für nasses oder trockenes Haar
- » Es bricht das Haar NICHT
- » Leicht und komfortabel in der Anwendung
- » Mit geringer statischer Aufladung
- » Chemische Beständigkeit
- » Gebogen zur besseren Anpassung an den Kopf
- » Zweifarbige Bürste (verschiedene Farben)

- » 3 altezze delle setole: 120 setole piccole, 123 medie, 119 grandi
- » Impugnatura ergonomica
- » Flessibile e delicata ma efficiente
- » Termoplastica di prima qualità
- » Per capelli bagnati o asciutti
- » NON rompe i capelli
- » Leggera e comoda da usare
- » Bassa carica statica
- » Resistente ai prodotti chimici
- » Con curvatura per adattarsi meglio alla testa
- » Spazzole bicolore (colori assortiti)



REF. 03881/97



Aussteller mit 120 entwirrenden Bürsten

Espositore 120 spazzole districanti

1
u.m.vta

1
box

» Verschiedene Farben
» Assortimento di colori

REF.04875

» Metallic-Farben
» Colori metallizzati

REF.04875/97

REF.04875/01



3d-Kugelbürste

Spazzole sferica 3D

1
u.m.vta

12
box

PLASTIC

3D-Kugelbürste. Verhindert, dass sich die Haare verheddern. Kann um 360° gedreht werden, um Locken und Wellen zu erzeugen. Seine abstehenden Borsten ermöglichen eine bessere Luftzirkulation und verkürzen die Trocknungszeit um die Hälfte.

Spazzole sferica 3D Evita che i capelli si aggroviglino Può essere ruotata di 360° per creare riccioli e onde. Le sue punte distanziate consentono una migliore circolazione dell'aria riducendo della metà i tempi di asciugatura.



REF. 04968

Farbige entwirrende Bürste
Spazzole districanti colori assortiti

» Kunststoffbündel
» Punte in plastica

S

REF. 04600

**Aussteller für entwirrende Bürsten**
Espositore per spazzole districanti

**STOP ruckt, STOP verwickelt
sich, Hör auf zu krausen**

**STOP cretini, STOP grovigli,
STOP all'effetto crespo**

L

REF. 04562



S

REF. 04886



L

REF. 04885



Aussteller mit 12 Spezialbürsten zum Entwirren. Mit sehr flexiblen Borsten in verschiedenen Höhen, die auch ohne Conditioner helfen, Knoten zu entwirren. STOPPT verheddern, STOPPT Ziehen, STOPPT Frizz. Jeder Aussteller hat 4 exklusive Drucke oder Designs.

Espositore con 12 spazzole speciali per districare. Con punte molto flessibili a diversi livelli che aiutano a sciogliere i nodi anche senza lavare con balsamo. STOP ai grovigli, STOP alle tirate, STOP all'effetto crespo. Ogni espositore dispone di 4 stampe o disegni esclusivi.

Aussteller 20 Holzbürsten Espositore per 20 spazzole in legno

1
u.m.vta

4
box

REF.03387

PLASTIC » Gerade Kunststoffborsten
» Punte dritte in plastica

WOOD



Enthält 4 Stück pro
Referenz
Include 4 spazzole
per referenza

REF. 03299
REF. 03298
REF. 00590
REF. 01994
REF. 00597

Aussteller mit 12 rechteckigen Holzbürsten Espositore per 12 spazzole rettangolari in legno

1
u.m.vta

1
box

REF.01166

PLASTIC » Gerade Kunststoffbündel
» Punte dritte in plastica

WOOD



Enthält 12 Stück
Include 12 unità

REF. 00590

Aussteller 12 große Gummibürsten Espositore per 12 spazzole pneumatiche grandi

1
u.m.vta

1
box

REF.01165

NYLON » Nylonbündel
» Setole in nylon



Incluye 12 unidades
Include 12 unità

REF. 00133



Aussteller mit 20 Thermobürsten

Espositore per 20 spazzole termiche



REF.01176

NYLON



Enthält 4 Stück pro
Referenz
Include 4 spazzole
per referenza

REF. 00579
REF. 00580
REF. 00581
REF. 00582
REF. 00780

Aussteller 12 TUNEL-Skelettbürsten

Espositore per 12 spazzole scheletro TUNEL



REF.01167

PLASTIC

» Kunststoffbündel mit Kugeln
» Setole in plastica con punte
arrotondate



Enthält 12 Stück
Include 12 unità

REF. 01165



Aussteller mit 24 beheizte bürsten

Espositore per 24 spazzole termico

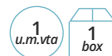

REF.07431

NYLON

» Nylonbündel
» Setole in nylon



NEW

Enthält 4 Einheiten
durch Referenzen

Include 4 unità
per riferimenti

REF. 03355
REF. 03356
REF. 03357
REF. 03358
REF. 03359
REF. 03360

Farbige Skelettbürsten

Spazzole scheletro colorata

PLASTIC

- » Kunststoffbündel mit kugeln
- » Setole in plastica con punte arrotondate

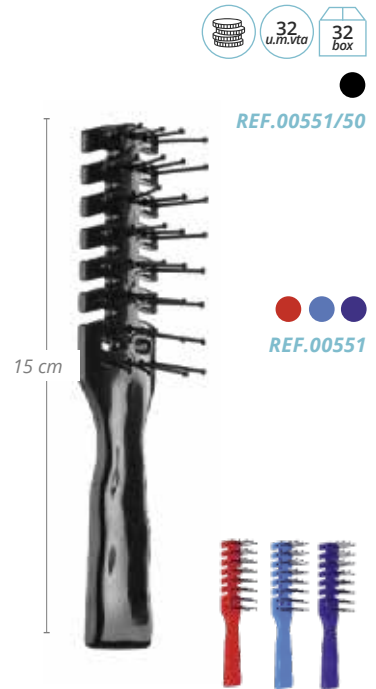
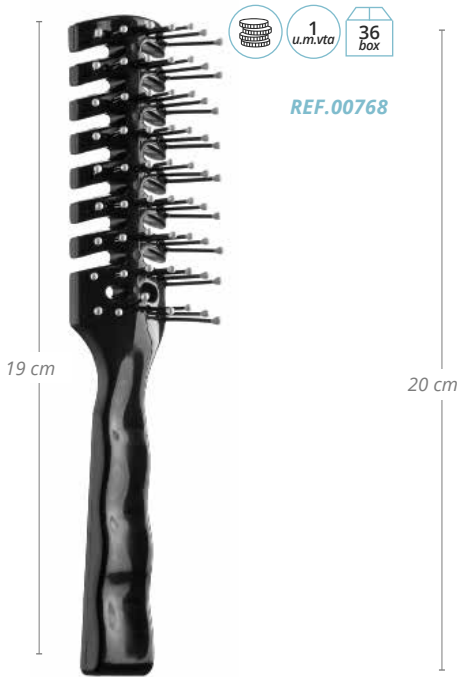

Skelettbürste metallic mit großer borstenkugel

Spazzola scheletro con due punte arrotondate in metallo, grande

PLASTIC

- » Kunststoffbündel mit Kugeln. Verschiedene Farben
- » Punte in plastica con sfere Colori assortiti

20 u.m.vta
20 box

REF.00550/97



Farbige Skelettbürsten aus Gummi
Spazzole scheletro con gomma colorata



- » Kunststoffbündel mit Kugeln
- » Setole in plastica con punte arrotondate

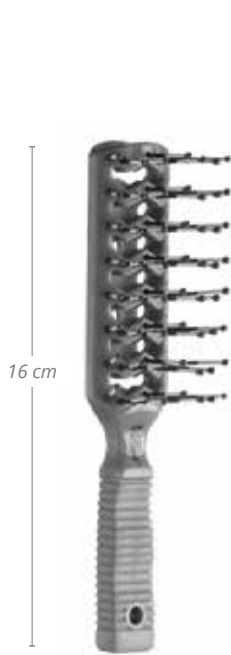

REF.00575

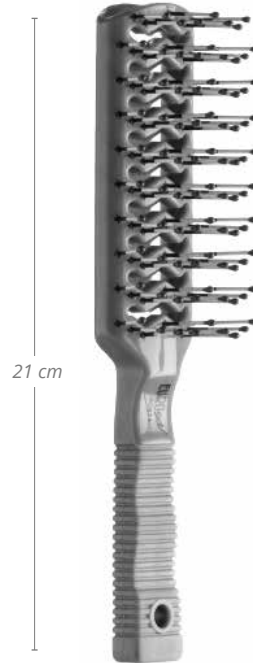

REF.00574



REF.00576



REF.00754



Skelettbürsten

Spazzole scheletro

PLASTIC

» Kunststoffbündel mit kugeln
» Setole in plastica con punte arrotondate

12
u.m.vta12
box

S

REF.03087

12
u.m.vta12
box

L

REF.03086

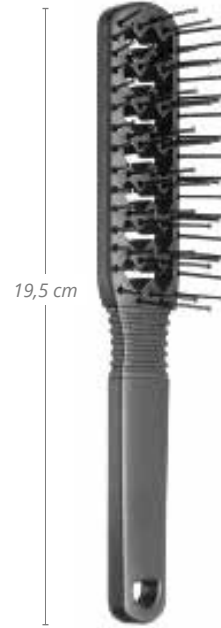
1
u.m.vta16
box

REF. 02203/50

REF. 02203



Anti-statische Skelettbürsten

Spazzole scheletro ANTISTATICHE

PLASTIC

» Kunststoffbündel mit kugeln
» Setole in plastica con punte arrotondate

S

REF.00585



17,50 cm

L

REF.00584



21 cm

1
u.m.vta12
box

Farbige Skelettbürsten Spazzole scheletro colorate

PLASTIC

» Kunststoffbündel
» Punte in plastica



Farbige Skelettbürsten Spazzole scheletro flessibili

PLASTIC

» Stahlstiften
» Punte metalliche

1 u.m.vta / 12 box

S
REF. 04405

L
REF. 04406



Farbige Skelett-Kurvenbürsten

Spazzole scheletro ricurve e colorate

PLASTIC

- » Kunststoffborsten mit kugel
- » Setole in plastica con punte arrotondate



REF. 02195

REF. 02195/50



REF.03201

22 cm

Gebogene Bürsten zur besseren Anpassung an die Kopfform, leicht und bequem in der Anwendung durch ergonomisches Design. Elf Reihen anatomisch geformter Kunststoffbündel mit kugelförmiger Oberfläche in der gleichen Farbe wie die Bürste.

Spazzole ricurve per un migliore adattamento alla forma della testa, leggere e comode da usare grazie al loro design ergonomico. Undici file di punte dalla forma anatomica in plastica con finitura a sfera dello stesso colore della Spazzole.

Doppel-Skelettbürsten

Spazzole scheletro doppie

PLASTIC

- » Kunststoffbündel mit kugeln verschiedene farben
- » Setole in plastica con punte arrotondate, colori assortiti



REF. 02182/50



REF. 02182

Kunststoffgriff Entwirrungsbürste

Spazzole districanti con manico in plastica



- » Zwei Höhen Bündel mit Kugeln
- » Punta a doppia altezza con doppia punta arrotondata



REF.06609

- » Bürstensortiment, die speziell für gebrochenes Haar entwickelt wurde



- » Linea di spazzole pensata appositamente per capelli che si spezzano

REF.06610



16,5 cm



21 cm

Flachbürste aus Plastik

Spazzole piatta in plastica



- » Kunststoffbündel mit Kugeln
- » Setole in plastica con punte arrotondate



REF.00571



REF.00570



Flachbürste aus Gummi

Spazzole piatta in gomma



- » Kunststoffbündel
- » Punta in plastica

REF. 04700

Faltbare Bürste mit Spiegel

Spazzole pieghevole con specchio



- » Kunststoffbündel mit Kugeln
- » Setole in plastica con punte arrotondate

REF.00329

REF.00329/50



Cepillo plástico

Spazzole in plastica



- » Kunststoffbündel
- » Punta in plastica

REF.01850/50

REF.01850



Lockenbürste
Spazzole arricciacapelli

REF. 00386

PLASTIC

**Professioneller Glättkamm**
Pettine professionale per piastra

REF. 03262

**Doppelte Thermobürste zum Glätten. Verwendung mit Trockner**
Doppia Spazzole termica per lisciare. Utilizzare con asciugacapelli

REF. 01957

- » Naturborsten
- » Setole di cinghiale

REF. 02365



Lauskamm**Pettini per la pulizia dei pidocchi**

PLASTIC

- » Polypropylen-Kamm
- » Kunststoffbündel

- » Pettine per la pulizia dei pidocchi in polipropilene
- » Punte in plastica

REF. 00443



REF. 00443/50

Lauskamm**Pettini per la pulizia dei pidocchi**

METAL

- » Stahlstiften
- » Setole metalliche

REF.03305

**Babybürste und Kamm****Spazzole e pettine per neonati**

REF.00670

REF.00670/75



REF.00670/70

Kamm mit Wasserwaage**Pettine con livelle**

Dank seiner drei Wasserwaagen ermöglicht er das Schneiden oder Scheiteln in einer perfekten geraden Linie

Grazie alle sue tre livelle, consente di tagliare o scalare in perfetta linea retta



REF. 04349

» Kamm-Reinigungsbürste

» Spazzole per la pulizia del pettine



REF. 00600

» Bürsten-Set und silbriger Kamm

» Set spazzola/pettine, color argento



REF. 03488



Keramik-ionische Thermobürste mit Gummigriff

Spazzole termoceramiche ioniche con manico in gomma



NYLON

- » Mit Keramikbeschichtung, um dem Haar mehr Glanz und Schutz zu verleihen, und ionischer Beschichtung, die Kräuseln verhindert
- » Mit Gummigriff mit rutschfester Oberfläche
- » Nylonbündel
- » Abnehmbarer Borsten
- » Mit Aufhänger



- » Con rivestimento in ceramica per donare ai capelli più lucentezza e protezione e ioniche per prevenire l'effetto crespo
- » Con impugnatura in gomma con finitura antiscivolo
- » Setole in nylon
- » Punta rimovibile
- » Con gancio



Thermobürste mit rundem Kunststoffgriff
Spazzole termiche con manico rotondo in plastica

NYLON

- » Nylonbündel
- » Mit Aufhänger

- » Setole in nylon
- » Con gancio

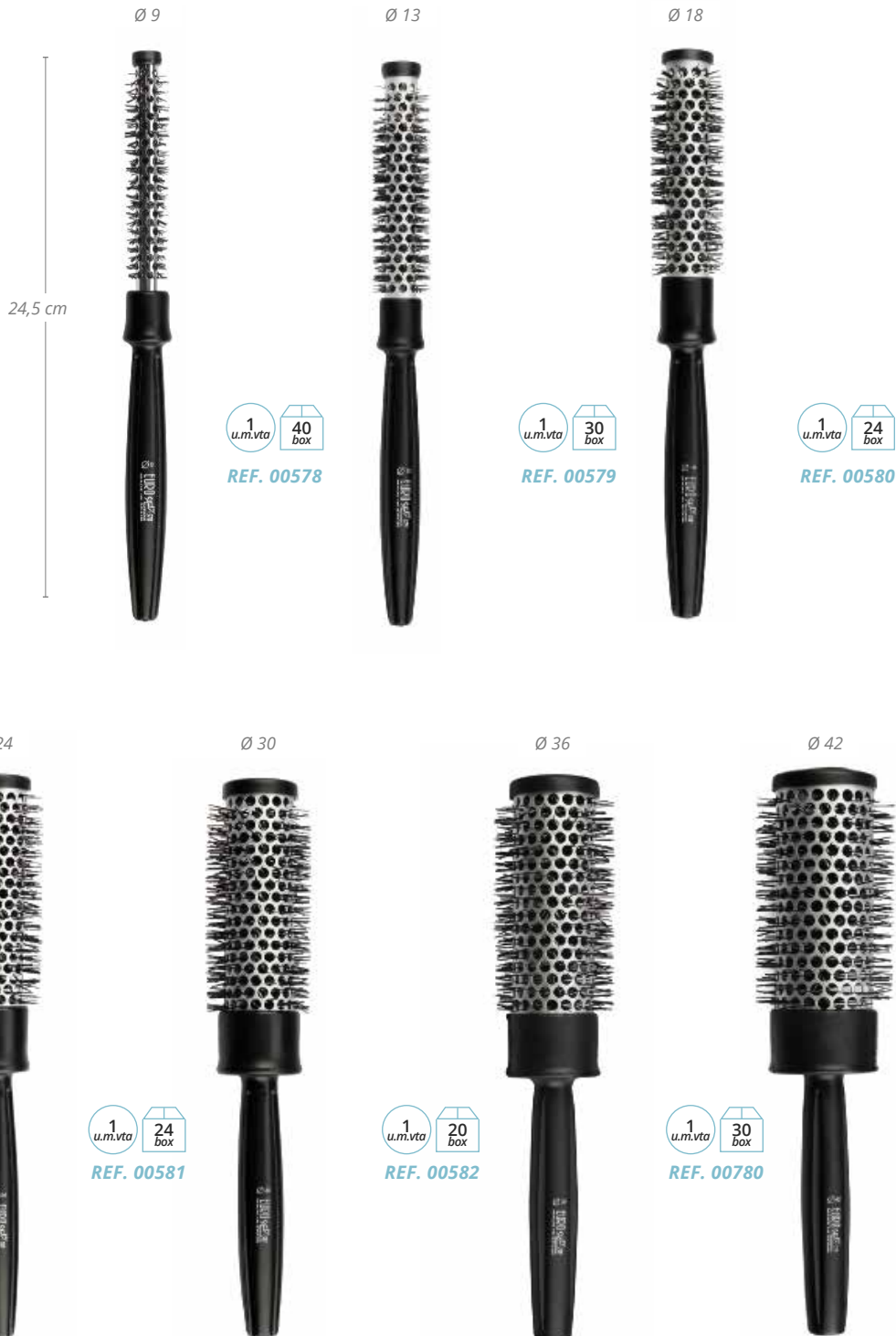
GESCHLOSSENES ALUMINIUMROHR
TUBO CHIUSO IN ALLUMINIO

Thermobürste mit Kunststoffgriff und offenem Aluminium-Flachrohr
Spazzole termiche con manico in plastica e tubo piatto aperto in alluminio



NYLON

- » Nylonbündel
- » Mit Aufhänger

- » Setole in nylon
- » Con gancio

Ø 13



1 u.m.vta 30 box

REF. 00355

Ø 18



1 u.m.vta 24 box

REF. 00356

Ø 24



1 u.m.vta 24 box

REF. 00357

Ø 30



1 u.m.vta 20 box

REF. 00358

Ø 36



1 u.m.vta 30 box

REF. 00359

Ø 42



1 u.m.vta 20 box

REF. 00360

Ø 50



1 u.m.vta 16 box

REF. 02661

Ø 61



1 u.m.vta 12 box

REF. 02662

Aluminium-Thermobürste mit Gummigriff
Spazzole termiche in alluminio con manico in gomma

NYLON

- » Nylonbündel
- » Mit Aufhänger

- » Setole in nylon
- » Con gancio

**Keramik Thermobürste mit Holzgriff**
Spazzole termoceramiche con manico in legno

NYLON

Die neueste Generation Keramik Thermobürsten hat einen zentralen Körper aus keramikbeschichtetem Aluminium, um eine hohe Festigkeit und eine gleichmäßige Wärmeverteilung entlang des Bürstenkörpers zu gewährleisten.

- » Nylonbündel
- » Mit Aufhänger

Le spazzole termoceramiche di ultima generazione hanno un corpo centrale in alluminio rivestito in ceramica per garantire un'elevata resistenza e una distribuzione uniforme del calore in tutto il corpo della Spazzole.

- » Setole in nylon
- » Con gancio



Thermobürste mit Holzgriff
Spazzole termiche con manico in legno

Der Bürstenkörper besteht aus Metall und Holz
Il corpo della Spazzole è metallico e in legno

» Naturborsten und Nylonbündel mit 2 Ebenen zur Verbesserung des Halts des Haars. In Spanien entwickelte Bürstenlinie für dichtes Haar mit Volumen

» Setole di cinghiale e nylon a 2 livelli per migliorare la tenuta dei capelli. Linea di spazzole sviluppata in Spagna per capelli densi e voluminosi

**Thermische Rundbürste mit Gummigriff**
Spazzole con manico termico in gomma

» Nylonbündel + Naturborsten. Der Bürstenkörper besteht aus Metall und Holz
» Setole di nylon + cinghiale Il corpo della Spazzole è metallico e in legno



Profi-Schneidekämme
Pettini da taglio professionali

REF. 04616

REF. 04616/97

REF. 04616/98

REF. 04616/99

**Spezial-Schneidekamm**
Pettine da taglio con denti speciali

REF. 00441

REF. 00441/98

REF. 00441/99



Spezial-Schneidekamm

Pettine da taglio con denti speciali



REF. 00442

» Verstärker
» Rinforzato

REF. 00424

» Extralang
» Super lungo

REF. 01470



17,5 cm



18,5 cm



21,5 cm

Großer Schneidekamm

Pettine da taglio grande



REF. 00115

REF. 00115/97

REF. 00115/98

REF. 00115/99



17,5 cm



Spezial-Schneidekamm
 Pettine da taglio con denti speciali

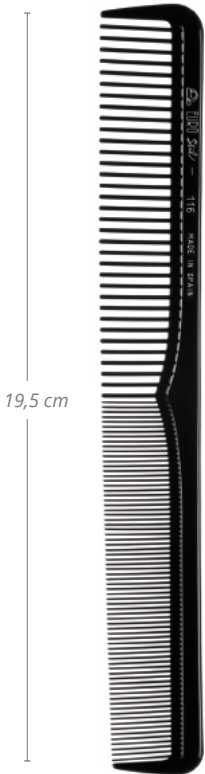

●
 REF. 00116

● ● ● ● ● ●
 REF. 00116/97

○ ● ● ● ● ●
 REF. 00116/98

● ● ● ● ● ● ● ● ● ● ● ●
 REF. 00116/99



Spezieller Friseurkamm
 Pettine speciale per parrucchiere

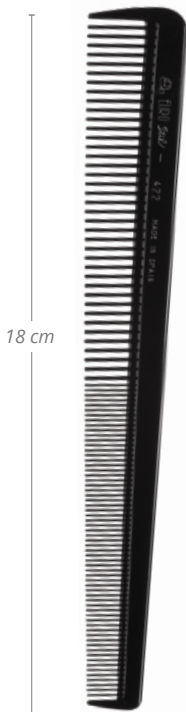

●
 REF. 00422

○ ● ● ● ● ●
 REF. 00422/98

● ● ● ● ● ● ● ● ● ● ● ●
 REF. 00422/99

○
 REF. 00422/58



Spezial-Nadelstielkamm

Pettine con denti speciali e punta



» Doppelte Zinkenhöhe
» Doppia altezza dei denti



REF. 00423



REF. 00423/97



REF. 00423/98



REF. 00423/99

20,5 cm



Nylon-Kamm

Pettine con denti in nylon



20,5 cm



REF. 00114



REF. 00114/99



Nylonkamm Stahlnadel
Pettine con denti in nylon e punta in metallo

REF. 00118

REF. 00118/99

**Kamm Metallnadel**
Pettine punta in metallo

REF. 01467



REF. 01468

 » Breit Metallnadel
 » Punta larghe

Schwarzer gebogener Fingerkamm

Pettine districante curvo nero



REF. 00127/50



REF. 00404/50

5-Zinken Fingerkamm, Spezialmetall

Pettine speciale con 5 punte in metallo



REF. 01469



REF. 01469/98



REF. 01469/99



5-Zinken Fingkamm Stahl
Pettine districante con 5 punte in metallo

REF. 00128

REF. 00128/98

REF. 00128/99

» Spezial-Schneidekamm für
» professioneller Maschinentrimmer

REF. 02472

» Professioneller Schneidekamm
» Pettine da taglio professionale

REF. 02304

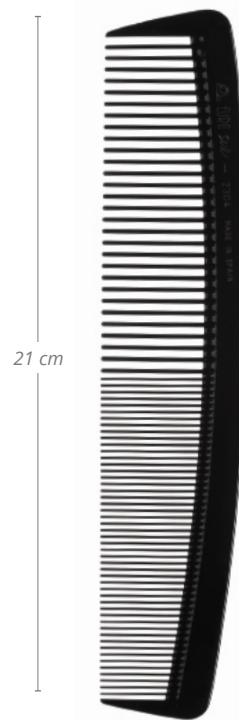
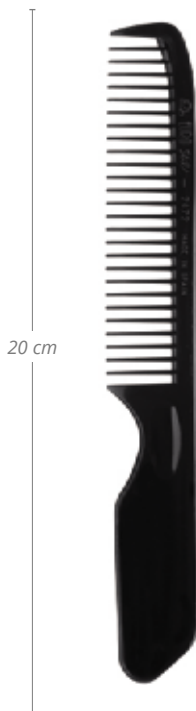
» Pettine da taglio speciale
» per rifilatrice professionale

Strähnen-Schneidkamm Pettine per meches



REF. 00455



REF. 00455/99



Gerader Schneidekamm Pettine da taglio dritto



REF. 00454

REF. 00454/99



Professionelle Kämmе Eurostil Pettine professionali Eurostil

» Doppelzinken
Kunststoffkamm
» Pettine da taglio
in plastica a
doppio dente



REF. 00452



18 cm

Spezial-Schneidekamm für Maschinenschnitt Eurostil Pettine taglio speciale macchina professionali Eurostil



MOD. 06802

REF. 07364

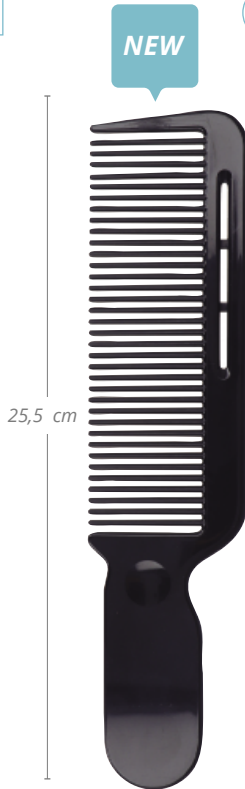

25,5 cm



MOD. 06802/82

REF. 07364/58

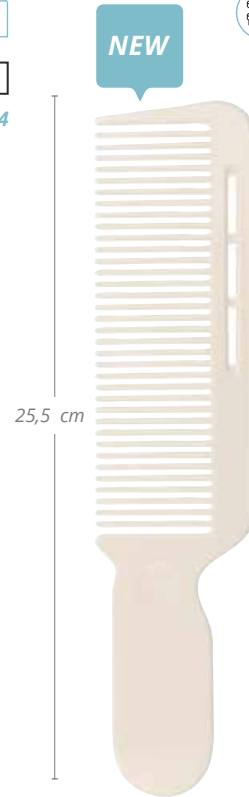

25,5 cm

Großer Frisierkamm Pettine a denti grandi



REF. 02183



25,5 cm

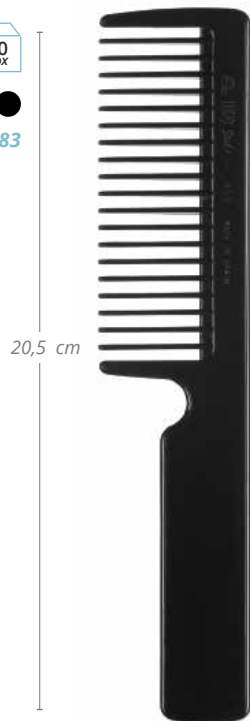

20,5 cm



REF. 00453



REF. 00453/99



Schwarzer Haarschneidekamm
Pettine da taglio nero



12

u.m.Vta

48

box

L

REF. 00136/50

REF. 00136

P.V.P.R 0,60€

22 cm



REF. 00136/97



REF. 00136/98



Spender 100 Käämme Einweg versiegelt
Dispenser 100 pettini monouso sigillati1
u.m.vta3
boxVersiegelter Kamm zur Gewährleistung
der Erstbenutzungsgarantie.

REF.03053

» Klassische Farben
» Colori classici

REF.03053/98

*Pettine sigillato per offrire la garanzia di non
essere stato utilizzato nei servizi precedenti.*

17,5 cm

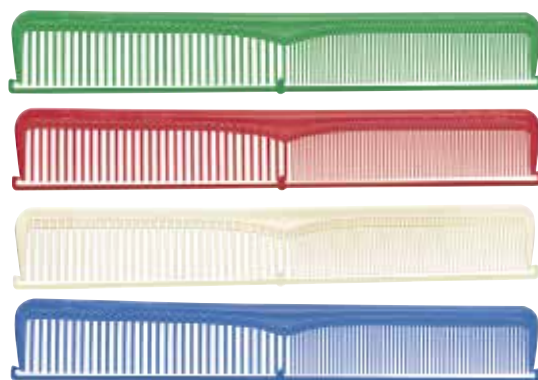
» Metallic Farben
» Colori metallizzati

REF.03053/97

» Sommer-Farben
» Colori estivi

REF.03053/99

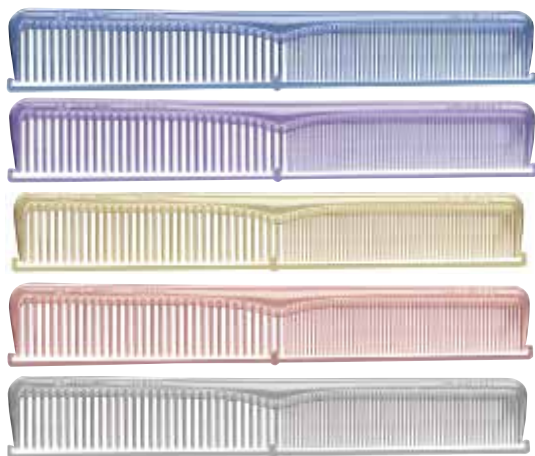

Professionelle Kämme farbig Pettini professionali colorati

Die Profi-Kämme jetzt in lustigen Farben, um Ihren Salon attraktiver und fröhlicher zu gestalten. Die Referenzen, die mit /99 enden, sind die von farbigen Kämmen: Grün, Blau, orange, Rosa, Pink und Lila. Auf dem Foto können Sie den Chromeffekt erkennen.

Pettini professionali ora in divertenti colori per rendere il tuo salone più attraente e allegro. I codici che terminano con /99 sono quelli dei pettini colorati assortiti: verde, blu, arancio, rosa, fucsia e viola. Nella foto è possibile vedere la gamma cromatica.

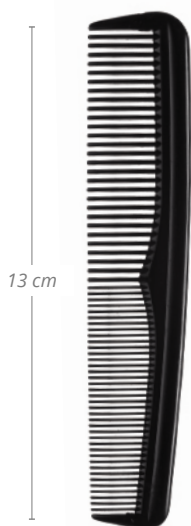

12
u.m.vta

60
box

REF. 00177/50

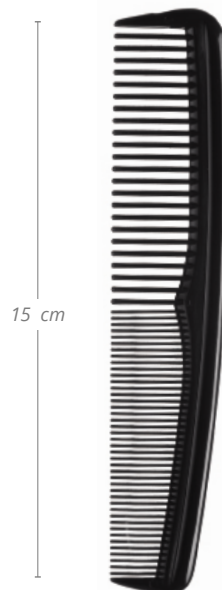

12
u.m.vta

60
box

REF. 00178/50

12
u.m.vta

120
box

REF. 00179/50



12
u.m.vta

60
box

REF. 00180/50



12
u.m.vta

72
box

REF. 00113



Kämme aus CARBON
Pettini in CARBONIO» Schneidekamm
» Pettine da taglio

REF. 02186



17,5 cm

» Schneidekamm
» Pettine da taglio

REF. 02216

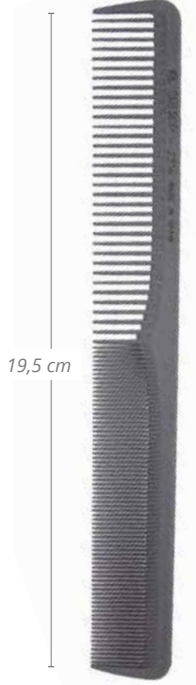

19,5 cm

» Spezial Zinkenkamm
» Pettine speciale da parrucchiere

REF. 02214

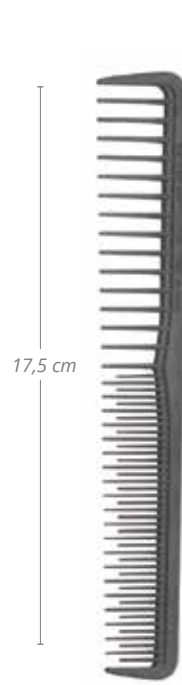

17,5 cm

» Frisierkamm
» Pettine speciale da parrucchiere

REF. 02215



18 cm

» Spezial Zinkekamm
» Punta speciale

REF. 02187



20,5 cm

» Großer Schneidekamm
» Pettine da taglio dritto

REF. 02188

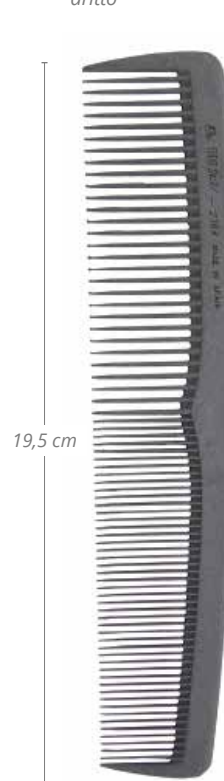

19,5 cm

Kämme aus CARBON**Pettini in CARBONIO**

- » Schneidekamm-Trennzinken
» Pettine da taglio con denti separatori

12
u.m.vta

240
box

REF. 03408



- » Schneidekamm-Trennzinken
» Pettine da taglio con denti separatori

12
u.m.vta

240
box

REF. 03407



- » Trennkamm
» Pettine con denti separatori

12
u.m.vta

192
box

REF. 03406

- » Professioneller
Metallnadelstielkamm
» Pettine professionale con
punta in metallo



12
u.m.vta

240
box

REF. 03411



- » Professioneller
Stielkamm
» Pettine
professionale

12
u.m.vta

240
box

REF. 03410



Auswahl kämme massenkonsum
Pettini senza logo, per grane distribuzione

120
u.m.vta

120
box

» Schneidekamm
 » Pettine da taglio

REF.00458



» Toupierkamm, Kunststoff
 » Pettine con punta in plastica

REF.00459

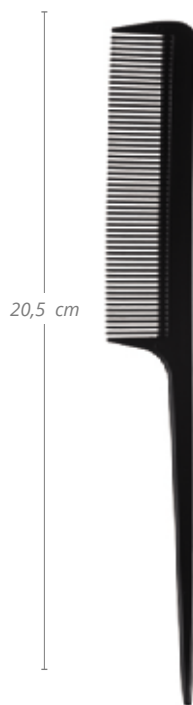

» 5-Zinken Kamm Stahl
 » Pettine con 5 punte in metallo

REF.00461



» Nadelstielkamm
 » Pettine con punta in metallo

REF.00460



Set mit 9 professionellen Friseurkämmе Nylon
Set di 9 pettini da parrucchiere professionali, nylon



» Enthält 9 professionelle und farbige Kämmе
 » Include 9 pettini colorati professionali

REF.03928/99

REF. 00453
 REF. 00454
 REF. 01469
 REF. 00423
 REF. 00441
 REF. 00115
 REF. 00116
 REF. 00118
 REF. 00422



Professioneller Kammkoffer
Astuccio per pettini professionali10
u.m.vta10
box» Enthält 6 professionelle Kämme
» Include 6 pettini professionali

REF.00950

» Enthält 4 professionelle Kämme und eine
Skelettbürste
» Include 4 pettini colorati professionali e una
Spazzole scheletro

REF.00951

REF. 00114
REF. 00115
REF. 00116
REF. 00118
REF. 00128
REF. 00136/50REF. 00114
REF. 00115
REF. 00136/50
REF. 00404/50
REF. 00550/50**Profi-Friseurset, Nylon**
Set professionale da parrucchiere, nylon» Enthält 9 professionelle Kämme
» Include 9 pettini professionali6
u.m.vta6
box

REF.03928

REF. 00114
REF. 00115
REF. 00116
REF. 00180/50
REF. 00404/50
REF. 00136/50
REF. 00118
REF. 01977
REF. 00962**Professionelles Friseur-Werkzeugset**
Set di strumenti professionali per parrucchieriprofissional» Enthält 9 professionelle Werkzeuge
» Include 9 strumenti professionali6
u.m.vta6
box

REF.04347

REF. 00114
REF. 00115
REF. 00116
REF. 00180/50
REF. 00404/50
REF. 00136/50
REF. 00118
REF. 01977
REF. 00962

PEGASUS-Schneidekamm
Pettini da taglio PEGASUS



- » Kunststoffkämme
- » Handgemacht
- » Antistatisch

- » Pettini in plastica
- » Fatti a mano
- » Antistatici

REF. 04242



REF. 04245



- » Kamm zum Schneiden
- » Pettine da taglio

REF. 04249

- » Spezielle Zinken
- » Punta speciale

REF. 04246

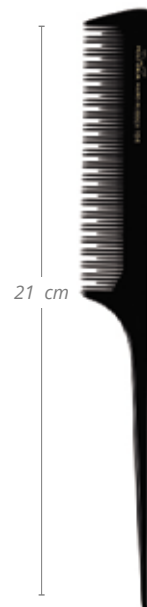

Schachtel mit 12 Stück Fingerkamm**Confezione da 12 unità di pettini districanti**

Pollié

1
u.m.vta40
box» 5 Zinken
» 5 punte

Pollié 334

» 5 Zinken
» 5 punte

Pollié 351

» 5 Metallzinken
» 5 punte in metallo

Pollié 309

REF.01886

REF.01887

REF.01885

**Schachtel mit 12 Stück Nadelstielkamm****Confezione da 12 unità di pettini con punta**1
u.m.vta40
box

Pollié 307

REF.01884

1
u.m.vta50
box

Pollié 308

REF.01883

» Stahlspitze
» Punta in metallo1
u.m.vta40
box

Pollié 310

REF.01882



Schachtel mit 12 Stück Schneidekamm Confezione da 12 unità di pettini da taglio

Pollié 

» Nylon
» Nylon

1 u.m.vta
40 box

Pollié 310

REF.01876



» Nylon
» Nylon

1 u.m.vta
40 box

Pollié 338

REF.01877



» Nylon
» Nylon

1 u.m.vta
40 box

Pollié 339

REF.01878



» Spezial
» Speciale

1 u.m.vta
50 box

Pollié 306

REF.01879

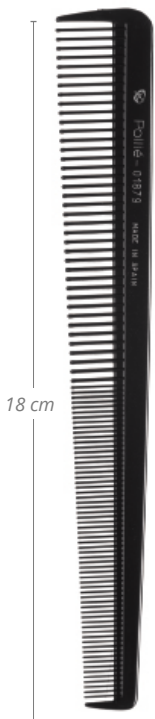

» Spezial
» Speciale

1 u.m.vta
40 box

Pollié 302

REF.01880

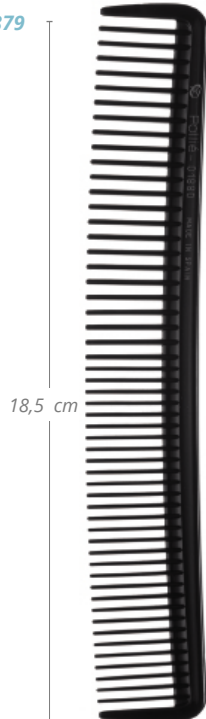

» Nylon
» Nylon

1 u.m.vta
50 box

Pollié 305

REF.01881



» Nylon
» Nylon

1 u.m.vta
50 box

Pollié 304

REF.01875



MATADOR-Frisierkamm
Pettini MATADOR
MATADOR
 PROFESSIONAL
1
u.m.vta12
box
 » Mit Griff
 » Con manico

2607/9

REF. 02607

 » Mit P.A.-Griff
 » Con manico P.A.

2607/9G

REF. 01638

2206/9

REF. 02206

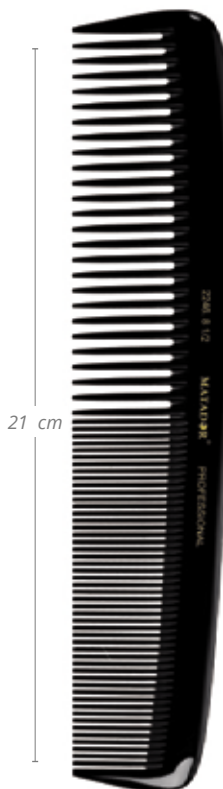

2246/8,5

REF. 02246



2246/7,5

REF. 01637



2255/7

REF. 02255

MATADOR-Frisierkamm

Pettini MATADOR

MATADOR
PROFESSIONAL



1
u.m.vta

12
box

» Spezial
» Speciale

2660/7,25

REF. 02660

» Mit P.A.-Griff
» Con manico P.A.

2677/7

REF. 02331

» Mit P.A.-Griff
» Con manico P.A.

2211/7

REF. 02211

18,5 cm



18 cm



18 cm



» Breiter
» Largo

2689/6,5

REF. 02689

» Spezial-Kamm
» Punta speciale

2614/7T

REF. 01639

» Schneidekamm
» Pettine da taglio

2614/7

REF. 02614

» Schneidekamm
» Pettine da taglio

2605/7

REF. 02330

23 cm



17,5 cm



17,5 cm



18 cm



MATADOR-Kämme
Pettini MATADOR

 » 8,5P-Zinkenstiel
 » Punta 8,5P

391/8G

REF. 01654

 » Spezial-
 Zinkenstiel 8
 » Punta speciale 8

391/8FT

REF. 01653

385/8,5G

REF. 01649

 » Metallnadelstielkamm
 » Punta in metallo

386/8,5G

REF. 01652



Wollen Sie mehr über die Ursprünge der Marke MATADOR erfahren?
Vuoi saperne di più sulle origini del marchio MATADOR?

Professionelle Silkomb-Kämme
Pettini professionali Silkomb

SILKOMB



1
u.m.vta

12
box

PRO-10

REF. 01520

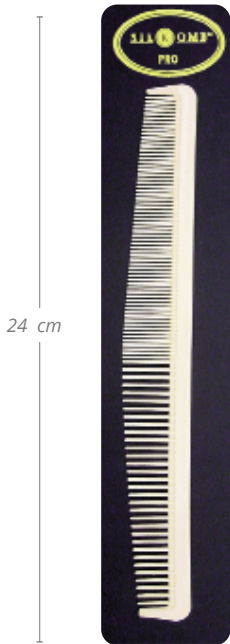

24 cm

PRO-11

REF. 01521



17,5 cm

PRO-20

REF. 01522



19 cm

PRO-30

REF. 01523



19 cm

PRO-40

REF. 01524



23 cm

PRO-50

REF. 01525



22,5 cm

Farbiger Frisierkamm
Pettini districanti colori assortiti12
u.m.vta48
box

M

REF. 00138



S

REF. 00400



L

REF. 00448

» Breiter Zinkenstiel
» Denti larghi

L

REF. 00412



S

REF. 00408

» Gebogener Zinkenstiel
» Denti larghi

Frisierkamm
Pettini districanti

- » Gebogener Frisierkamm, groß
- » *Pettine districante denti curvi, grande*



REF. 00407

- » Frisierkamm mit Gummigriff
- » *Pettine districante con manico in gomma*

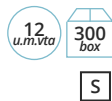

REF. 00425

**Gerader Schneidekamm**
Pettine da taglio dritto

S

REF. 00111

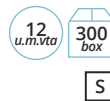

S

REF. 00111/50



L

REF. 00444

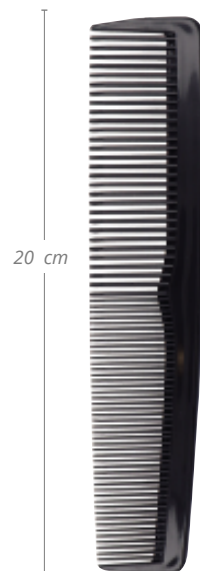

Schneidekamm

Pettini da taglio



» Doppelter Zinken
» Denti doppi

12
u.m.vta 48
box

REF. 00435

» Farbige Strähnen
» Pettine separatore colorato

12
u.m.vta 60
box

REF. 00427

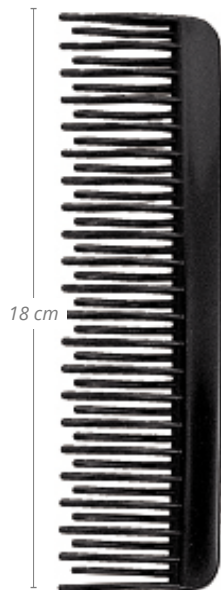

» Strähnen
» Pettine per meches

12
u.m.vta 60
box

REF. 00471

» Gewelltes Haar
» Capelli mossi

12
u.m.vta 60
box

REF. 00420

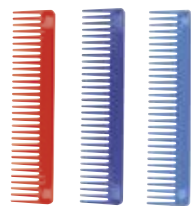
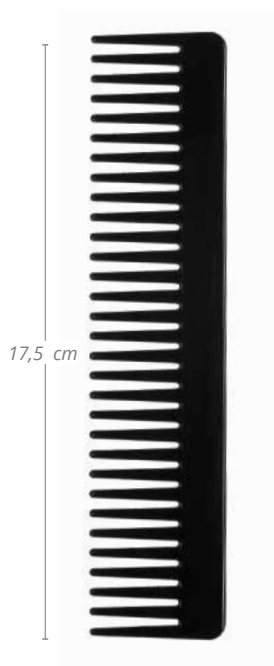

Farbiger Fingerkamm
Pettine districante colori assortiti

S

REF. 00419

Transparent
Trasparente
REF. 00419/56

L

REF. 00426

Stufenkamm-Strähnen
Pettine scalato per meches

REF.00421

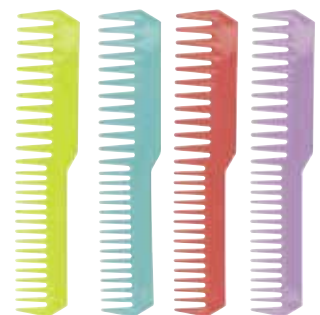

Dose mit 60 farbigen Toupinkämme
Barattolo 60 pettini colorati per cotonare

2
u.m.vta

2
box

» Kunststoffzinken
 » Punte in plastica

MOD. 00423

» Metallic Farben
 » Colori metallizzati

MOD. 00423

REF.03251

REF.03251/97



Dose mit 60 Schneidekämme
Barattolo 60 pettini colori assortiti

» Kunststoffzinken
 » Punte in plastica

2
u.m.vta

2
box

MOD. 00115

REF.03845

» Metallic Farben
 » Colori metallizzati

2
u.m.vta

2
box

MOD. 00115

REF.03845/97



Dose mit 60 Schneidekämme Barattolo 60 pettini da taglio

- » Kunststoffzinken
- » Punta in plastica

MOD. 00116/99

REF.03250

2
u.m.vta2
box

MOD. 00422

REF.03847



Dose 60 farbige Kämmе barattolo 60 pettini colori assortiti

- » Kunststoffzinken
- » Punta in plastica

2
u.m.vta2
box

MOD. 00441

REF.03848

Dose 24 Toupiеrbürstеn mit doppelter Höhe barattolo 24 spazzole colori assortiti, per cotonare

- » Kunststoffborsten
- » Zwei Höhen

- » Punta in plastica
- » Doppia altezza

1
u.m.vta20
box

MOD. 00115

REF.04350



Dose mit 60 Gabelkämme Barattolo 60 pettini districanti colori assortiti

- » Kunststoffzinken
- » 5 Zinken metallic

- » Punta in plastica
- » 5 punte in metallo



MOD. 00128

REF.03853



Dose mit 24 Toupierkämme Barattolo da 24 pettini per cotonare colori assortiti

- » Kunststoffzinken
- » 5 Zinken metallic

- » Punta in plastica
- » 5 punte in metallo



MOD. 01469/99

REF.03852



Dose mit 30 Toupierbürsten Barattolo da 30 spazzole colorate per cotonare

- » Kunststoffborsten
- » Durchscheinende Farben

- » Punta in plastica
- » Colori traslucidi



MOD. 03880

REF.04222



Dose mit 60 farbigen Kämmen Barattolo da 60 pettini colori assortiti

- » Metallic Zinken
- » Punta in metallo



MOD. 00118

REF.03850



Dose mit farbigen Kämmen · Barattolo pettini, colori assortiti

Schachtel mit 30 durchsichtigen, sortierten Farbkämme
Barattolo da 30 pettini traslucidi di colori assortiti

- » Durchsichtige Plastikbox
- » Scatola di plastica trasparente



MOD. 00136

REF.01854



22 cm

Dose mit 60 Kämmen in verschiedenen durchscheinenden Farben
Barattolo da 60 pettini a colori trasparenti assortiti



MOD. 00116

REF.01621



19,5 cm

Dose mit 60 Kämmen in verschiedenen durchscheinenden Farben, ideal zum Toupieren
Barattolo da 60 pettini a colori trasparenti assortiti ideali per cotonare



MOD. 00423

REF.01625

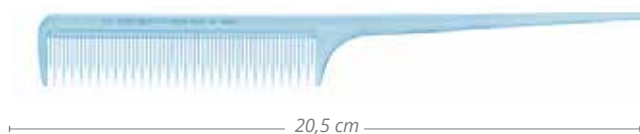
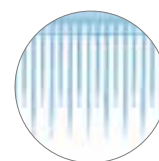

20,5 cm

Massagebürste Spazzole da massaggio

- » Silikonborsten
- » Punte in silicone



REF.04427



Dose mit 12 bunten Massagebürsten Barattolo da 12 spazzole colorate per massaggiare

- » Kunststoffbündel
- » Punte in plastica

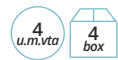

REF.04403



Dose mit 24 Mini-Gummibürsten Barattolo da 24 spazzole pneumatiche mini

- » Kunststoffbündel mit Kugeln
- » Setole in plastica, punte arrotondate



REF.02471



Dose mit 24 Mini-Faltbürsten Barattolo da 24 spazzole pieghevoli mini

- » Kunststoffbündel mit Kugeln
- » Mit Spiegel



REF.02789



Holzfarbener Friesierkamm

Pettini districanti color legno



» Gebogene Zinken
» Denti ricurvi

REF. 00408/55

» Gebogene Zinken
» Denti ricurvi

REF. 00407/55

REF. 00136/55



Strähnenkamm

Pettine per meches



REF. 00409/99

REF. 00409

REF. 00409/50



Holzfarbene Kämmе
Pettini color legno

» Strähnschneidekamm
» Pettine per meches

REF. 00410

» Gabelkamm 5
Zinken
» Pettine per meches

REF. 00404

» Gabelkamm 5
gebogene Zinken
» Pettine districante
con 5 punte ricurve

REF. 00127

**Kämmе aus Holz**
Pettini in legno

» Frisierkamm
» Districante

REF. 04240



» Haarscheidekamm
» Da taglio

REF. 04241



Professioneller Fingerkamm

Pettine districante afro professionale



- » Doppelzinken
- » Doppia punta

REF. 00450



Fingerkamm

Pettine districante afro



- » Doppelzinken
- » Doppia punta

REF. 01852



Fingerkamm

Pettine districante afro



- » Großer. Doppelzinken
- » Doppia punta. Grande



REF. 00414



- » Doppelzinken. Klein
- » Doppia punta. Piccolo



REF. 00417



Mit dem Fingerkamm können Sie eine dicke Toupeierung erzeugen, reichlich und unordentlich, aber mit Stil

Con il pettine districante puoi creare una pettinatura spessa, sostanziosa e disordinata, ma elegante

Professioneller Fingerkamm

Pettine districante professionale

- » Doppelzinken
- » Groß schwarz

- » Doppia punta
- » Extra-large nero



19,5 cm



REF. 00451

- » Doppelzinken
- » Groß farbig

- » Doppia punta
- » Extra-large colorato



19,5 cm



REF. 00434

Schwarzer Fingerkamm

Pettine districante afro

- » Faltbar
- » Pieghevole



REF. 00432

- » 11 Zinken. Mittel
- » 11 punte. Medio



REF. 00402/50

- » 11 Zinken. Groß
- » 11 punte. Grande



REF. 00403/50



19 cm



16,5 cm



17,2 cm

Fingerkamm aus Holz

Pettine districante afro in legno

- » 11 Zinken. Klein
- » 11 punte. Piccolo

REF. 00406

- » 11 Zinken. Mittel
- » 11 punte. Medio

REF. 00402

- » 11 Zinken. Groß
- » 11 punte. Grande

REF. 00403



11 cm



16,5 cm



17,2 cm

Acetat-Schneidekamm
Pettine da taglio in acetato



REF. 04236

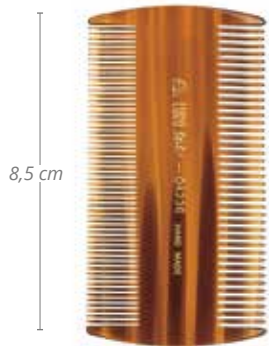

Muschel/Acetat Schneidekamm
Pettine color tartaruga in acetato



REF. 04238



REF. 04237



18,7 cm

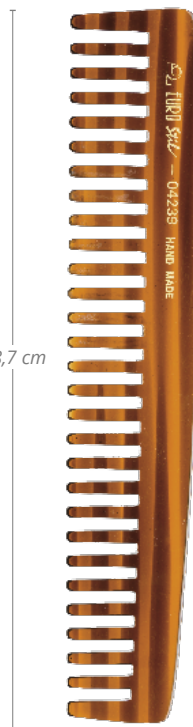

REF. 04239



Friseurkamm aus Muschel/Acetat
Pettini in acetato per parrucchiere

REF. 04230

REF. 04231

REF. 04232

REF. 04229



13,8 cm

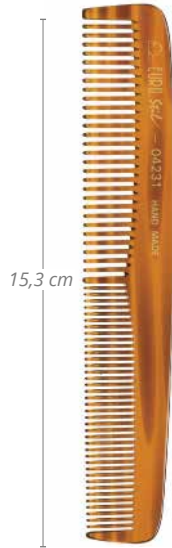

15,3 cm

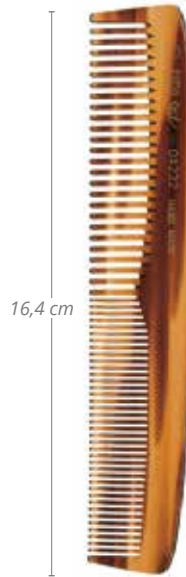

16,4 cm

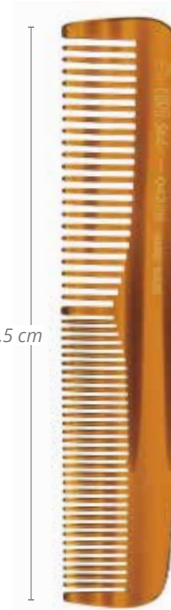

19,5 cm

Verstärkter Muschel/Acetat Schneidekamm
Pettini color tartaruga in acetato rinforzato

REF. 04233

REF. 04234

» Stahlspeiß
» Punta in metallo

REF. 04235

» Kamm mit
» Speiß
Muscheleffekt
» Pettine con punta

REF. 04262



17,8 cm



18,8 cm



22,2 cm

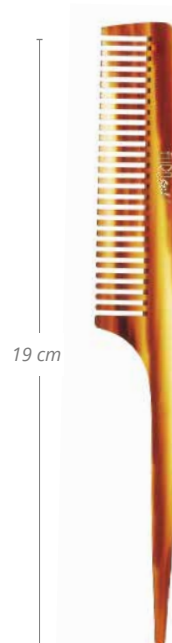

19 cm

Muschel/Acetat Kamm

Pettini color tartaruga in acetato



» Schneidekamm
» Acetat

12
u.m.vta 120
box

REF. 00177

» Pettine da taglio
» Acetato

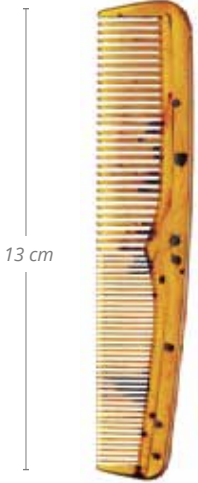

» Schneidekamm
» Acetat

12
u.m.vta 60
box

REF. 00178

» Pettine da taglio
» Acetato

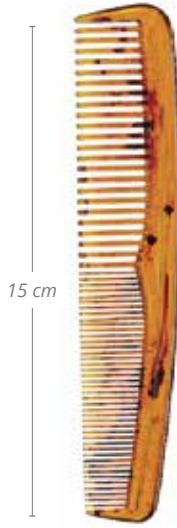

» SchneidekammAcetat
» Pettine da taglio
» Acetato

1
u.m.vta 120
box

REF. 00179

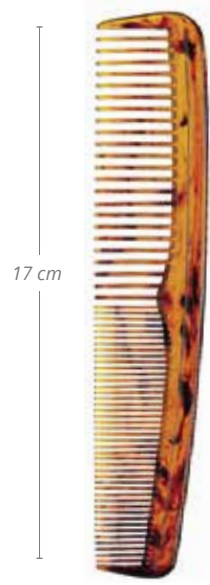

» SchneidekammAcetat
» Pettine da taglio
» Acetato

1
u.m.vta 120
box

REF. 00180

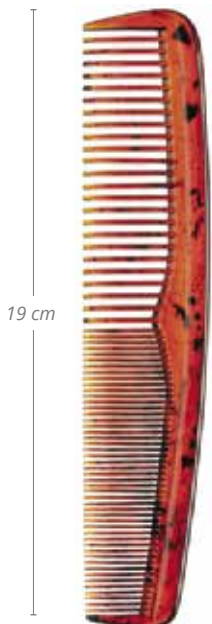

12
u.m.vta 120
box

REF. 00444/51

» Frisierkamm
» Muscheleffekt
» Pettine districante
» Tartaruga

12
u.m.vta 60
box

REF. 00136/51



DER UMWELT VERPFLICHTET PRODUKTLINIE AUS RECYCELTEM MATERIAL (EIGENE HERSTELLUNG)

Nachhaltigkeitsstudie für Produkte durch das Unternehmen LEITAT mit dem Hauptziel, eine nachhaltigere Produktlinie zu schaffen

Konkret gesagt reduziert die Schale (Ref. 00655) die globale Umweltauswirkung um 26%, der Pinsel (Ref. 00102) um 28%, der Kamm (Ref. 00136) um 28% und der Kamm (Ref. 00409) um 21%, unter Verwendung von recyceltem Polypropylen.

Recyceltes Polypropylen zu verwenden, ermöglicht die Reduzierung der Umweltwirkungen um 25 bis 28%. Die Rohstoffgewinnung sorgt für 17 bis 37% der Auswirkungen bei mit neuen Polypropylen hergestellten Produkten.



IL NOSTRO IMPEGNO PER L'AMBIENTE LINEA DI PRODOTTI IN MATERIALE RICICLATO (PRODUZIONE PROPRIA)

Studio sulla sostenibilità dei prodotti realizzato dall'azienda LEITAT come obiettivo principale per creare una linea di prodotti più sostenibile

Nello specifico la vaschetta rif.00655 riduce il suo impatto ambientale complessivo del 26%, la spatola rif. 00102 del 28%, il pettine rif. 00136 del 28% e il pettine rif.00409 del 21% con l'utilizzo di polipropilene riciclato.

L'utilizzo di polipropilene riciclato riduce l'impatto ambientale tra il 25 e il 28%. Gli impatti dovuti all'ottenimento di materie prime rappresentano tra il 17% e il 37% degli impatti nei prodotti realizzati con polipropilene vergine

Verstärkter Acetatschalenschlägerkamm
Pettine a conchiglia in acetato rinforzato



REF.00136/222



NEW



REF.00409/222



NEW



Große Palette aus recyceltem Material
Grande pallet di materiale riciclato



REF.00102/222



NEW



Große recycelte Plastikschale
Grande ciotola di plastica riciclata



REF.00655/222



NEW



Lockenwickler, duttkissen und kopfbedeckungen

BIGODINI,
CUFFIE,
RETINE

*Lockenwickler, Dauerwellenwickler,
Haarnadeln, Schaumlockenwickler,
Haarnetze, Schutzhauben...*

*Bigodini, forcine, bigodini
flessibili, retine, cuffie...*



Beutel 12 Dauerwellenwickler aus geriffeltem Holz
Sacchetto da 12 bigodini permanente in legno



N° 0

REF.01544



N° 3

REF.01546



N° 5

REF.01548



N° 8

REF.01571



Beutel 6 Dauerwellenwickler aus Holz
Sacchetto da 6 bigodini permanente in legno



N° 10

REF.01573



N° 12

REF.01550



Beutel 10 Lockenwickler aus geriffeltem Holz Sacchetto da 10 bigodini permanente in legno

REF.01559



REF.01560



REF.01561



REF.01562



Beutel 12 Dauerwellenwickler Sacchetto da 12 bigodini permanente



» Kunststoff, zweifarbig gewellt

» Plastica, bicolore ondulato

REF.01500



REF.01501

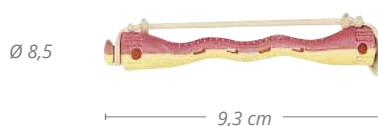

REF.01502

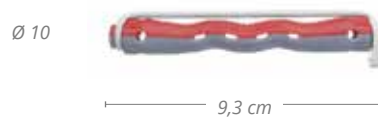

REF.01503



REF.01504



Beutel 100 Dauerwellenwickler Sacchetto da 100 bigodini permanente

» Kunststoff

» Plastica

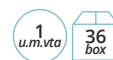

REF.01554

N° 1



REF.01555

N° 2



REF.01556

N° 3



REF.01557

N° 4



REF.01558

N° 5



Beutel 12 geriffelte Kunststofflockenwickler Sacchetto da 12 bigodini in plastica scanalata

1
u.m.vta

24
box



5,9 cm

REF.01239

» Inklusive einer Tasche mit Haarnadeln
» Include un sacchetto con forcine



5,9 cm

REF.01241



5,9 cm

REF.01242



5,9 cm

REF.01243



Inklusive einer Tasche mit Haarnadeln Sacchetto da 50 elastici per bigodini

» Flach
» Lang

» Piatti
» Lunghi

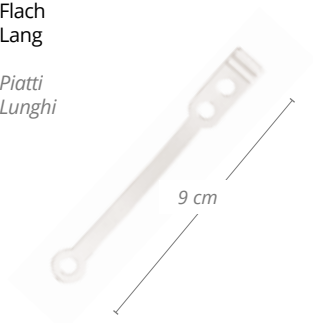

12
u.m.vta

12
box

REF.00864

» Rund
» Lang

» Rotondi
» Lunghi

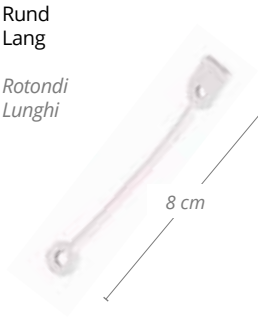

12
u.m.vta

12
box

REF.00862

» Silikon
» Kurz

» In silicone
» Corti

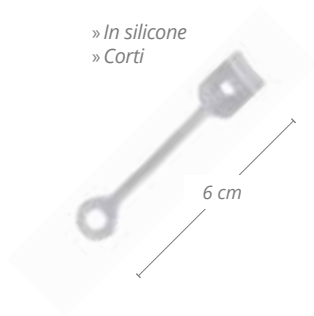

1
u.m.vta

50
box

REF.01490

» Flach
» Kurz

» Piatti
» Corti

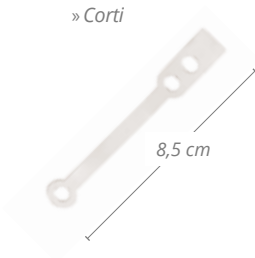

12
u.m.vta

12
box

REF.00865

» Rund
» Kurz

» Rotondi
» Corti

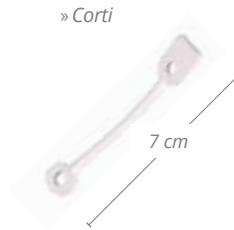

12
u.m.vta

12
box

REF.00863

Ringe Dauerwellenwickler 100 gr
Sacchetto da 100gr di elastici per bigodini

REF.00653

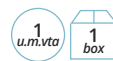

Für Dauerwellenwickler aus Holz
 Per bigodini di legno

Beutel mit 50 Ersatzgummis
Sacchetto da 50 elastici di ricambio

REF.00867



Für Dauerwellenwickler aus Holz
 Per bigodini di legno

Beutel 12 Plastik-Dauerwellenwickler
Sacchetto da 12 bigodini permanente in plastica

REF.00900

- » Große Version
- » Kunststoff
- » Zweifarbig
- » Lunghi
- » Plastica
- » Bicolore

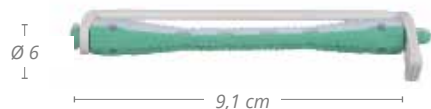

REF.00901



REF.00902

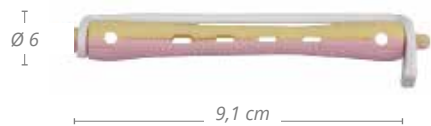

REF.00903

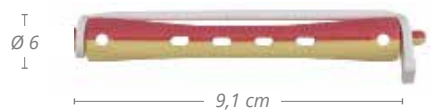

REF.00904

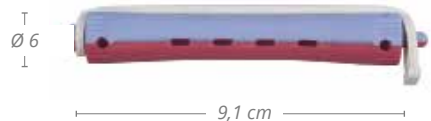

REF.00905

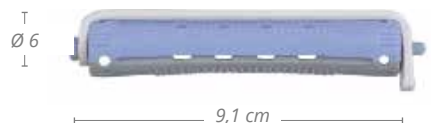

REF.00906

Beutel 12 Plastik-Dauerwellenwickler
Sacchetto da 12 bigodini permanente in plastica

REF.00907

- » Kurze Version
- » Kunststoff
- » Zweifarbig
- » Lunghi
- » Plastica
- » Bicolore



REF.00908



REF.00909



REF.00910



REF.00911

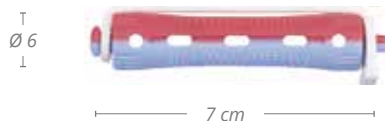

REF.00912

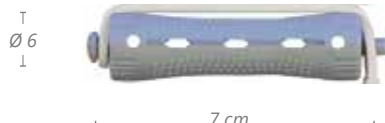

REF.00913



Lange und kurze Schaumlockenwickler: 12 Stück
Bigodini flessibili lunghi e corti: 12 unità



Lang
Lunghi

Kurz
Corti

REF. 01244

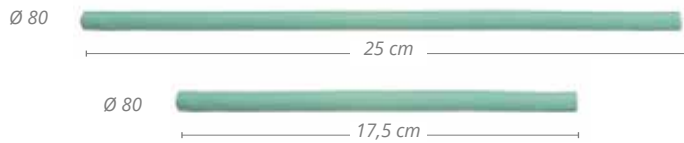

REF. 01251

REF. 01245

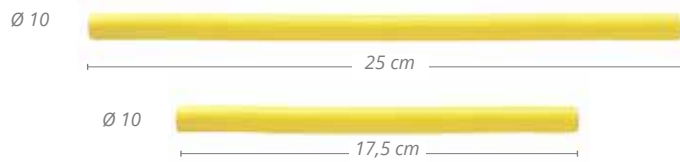

REF. 01252

REF. 01246

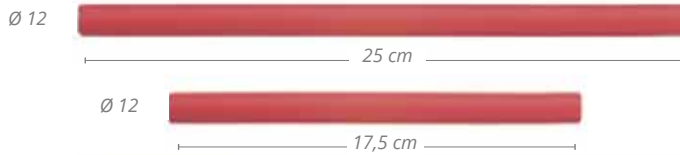

REF. 01253

REF. 01247

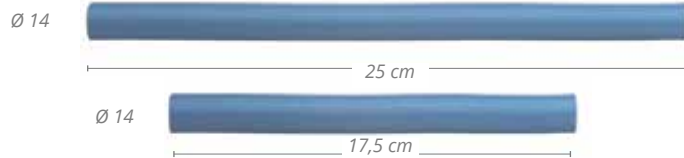

REF. 01254

REF. 01248

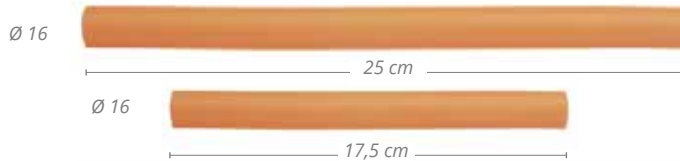

REF. 01255

REF. 01249

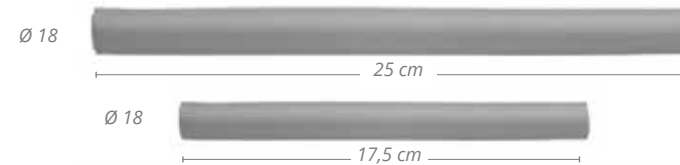

REF. 01256

REF. 01250



REF. 01257

Beutel 6 lockenwickler draht
Sacchetto da 6 rulli in rete



» Blau
 » Blu



Ø 10

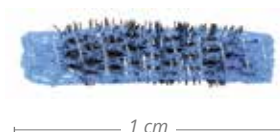

NEW

1 cm

1
u.m.vta

12
box

6 u

REF. 07333

» Rosa
 » Rosa



Ø 13



NEW

1,3 cm

1
u.m.vta

12
box

6 u

REF. 07334

» Lila
 » Viola



Ø 17



NEW

1,7 cm

1
u.m.vta

12
box

6 u

REF. 07335

» Rosa
 » Rosa



Ø 22

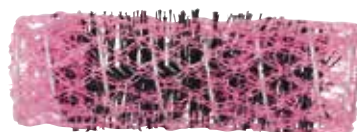

NEW

2,2 cm

1
u.m.vta

12
box

6 u

REF. 07336

Beutel 6 lockenwickler draht schwarz
Sacchetto da 6 rulli in rete nera



NEW

Ø 28

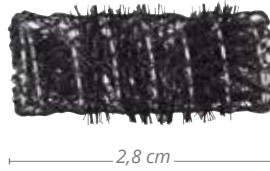

2,8 cm

1
u.m.vta12
box

6 u

REF. 07337



NEW

Ø 32



3,2 cm

1
u.m.vta12
box

6 u

REF. 07338



NEW

Ø 36

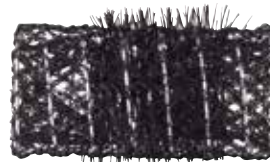

3,6 cm

1
u.m.vta12
box

6 u

REF. 07339



NEW

Ø 45



4,5 cm

1
u.m.vta12
box

6 u

REF. 07340

Beutel mit Klettwickler Sacchetto bigodini adesivi



» Grün
» Verdi

1 u.m.vta
80 box
9 u

REF. 00015

Ø 23

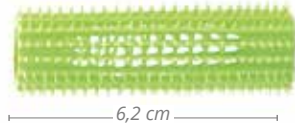

6,2 cm

» Orange
» Arancioni

1 u.m.vta
70 box
8 u

REF. 00016

Ø 27

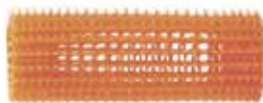

6,2 cm

» Gelb
» Gialli

1 u.m.vta
45 box
8 u

REF. 00017

Ø 31



6,2 cm

» Rot
» Rossi

1 u.m.vta
40 box
6 u

REF. 00018

Ø 39



6,2 cm

» Blau
» Blu

1 u.m.vta
25 box
5 u

REF. 00047

Ø 45

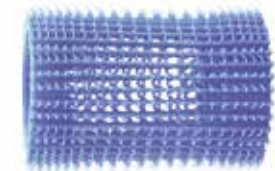

6,2 cm

» Lila
» Viola

1 u.m.vta
20 box
5 u

REF. 00024

Ø 55

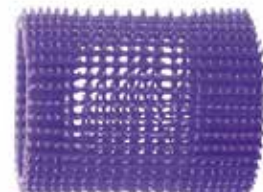

6,2 cm

» Rosa
» Rosa

1 u.m.vta
16 box
4 u

REF. 00025

Ø 65



6,2 cm

Klettwickler-Kit 60 Stück Kit arricciacapelli 60 rotoli

» 12 Klettwickler in 5 Größen
» 12 rotoli per 5 misure

1 u.m.vta
12 box
60 u

REF. 04428



Beutel mit Heißwickler Confezione di bigodini termici

Achtung, nicht in der Mikrowelle verwenden
Attenzione, non scaldare nel microonde



» Klein
» Piccoli

6 u

REF. 00019

» Klein
» Medi

6 u

REF. 04024

» Groß
» Grandi

5 u

REF. 00020

Ø 17



6,5 cm

Ø 20



6,5 cm

Ø 24



6,5 cm

Schachtel mit Heißwickler Confezione di bigodini termici

Achtung, nicht in der Mikrowelle verwenden
Attenzione, non scaldare nel microonde



» Klein
» Piccoli

6 u

REF. 03391

» Klein
» Medi

6 u

REF. 03392

Ø 17



6,5 cm

Ø 23



6,5 cm

» Groß
» Grandi

5 u

REF. 03393

» Groß
» Grandi

4 u

REF. 03394

Ø 28



6,5 cm

Ø 32



6,5 cm

Beutel mit 12 Schaumrollenwickler Confezione da 12 bigodini gommaspugna



» Blau
» Blu

REF. 04019

Beutel mit 12 Schaumrollenwickler Confezione da 12 bigodini gommaspugna



» Grün
» Verdi

REF. 04021

Ø 15



6 cm

Ø 25



6 cm

» Gelb
» Gialli

REF. 04020

» Rosa
» Rosa

REF. 04023

Ø 20



6 cm

Ø 35



6 cm

Beutel mit 12 Lockenwickler in durchsichtigem Rosa
Sacchetto da 12 bigodini super aderenti



12
u.m.vta

120
box

N°0

REF. 00000



12
u.m.vta

72
box

N°1

REF. 00001

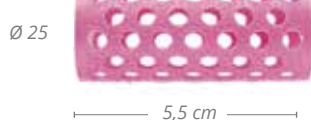
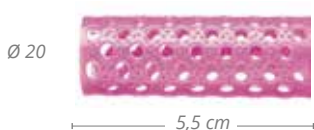

12
u.m.vta

240
box

N°2

REF. 00002

12
u.m.vta

144
box

N°3

REF. 00003



12
u.m.vta

120
box

N°4

REF. 00004

12
u.m.vta

72
box

N°5

REF. 00005

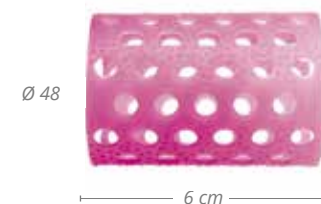

12
u.m.vta

60
box

N°6

REF. 00006

12
u.m.vta

48
box

N°7

REF. 00007



12
u.m.vta

24
box

N°8

REF. 00008

Die bei Industrias Oriol hergestellten rosa Lockenwickler sind ein Klassiker ihrer Firmengeschichte und sind über die Jahre immer hoch geschätzt.

I rulli rosa prodotti da Industrias Oriol sono un classico molto apprezzato in tutti gli anni della storia dell'azienda.

Beutel mit 12 extra starken Lockenwickler (einschließlich Beutel mit Haarnadeln)
Sacchetto da 12 bigodini super aderenti (include sacchetto con forcine)



» Speziell für Afro-Haar und widerstandsfähiges Haar
 » "Speciale" per capelli afro e capelli resistenti

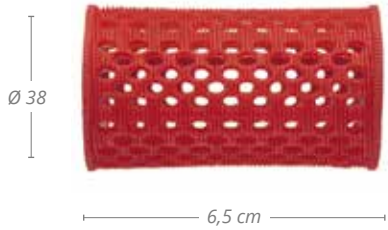

REF. 04665

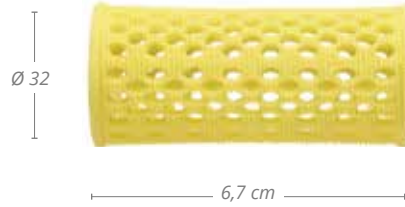

REF. 04666

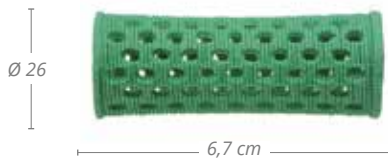

REF. 04667

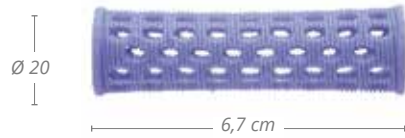

REF. 04668



REF. 04669



REF. 04670



Beutel mit 6 Klettwicklern extra stark
Sacchetto da 6 bigodini super adesivi

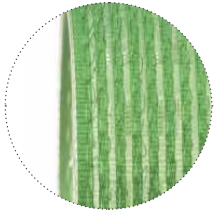

Ø 13



6 cm

REF.00009

Ø 15



6 cm

REF.00031

Ø 21



6 cm

REF.00010

Ø 24



6 cm

REF.00011

Ø 28



6 cm

REF.00012

Ø 32



6 cm

REF.00013

Ø 36



6 cm

REF.00014

Beutel mit 3 Klettwicklern extra stark
Confezione da 3 bigodini super adesivi

Ø 40



6 cm

REF.00028

Ø 44



6 cm

REF.00032

Ø 48



6 cm

REF.00033

Ø 60



6 cm

REF.00034

Beutel mit 12 Klettwicklern extra stark (Farben können variieren)
Sacchetto da 12 bigodini adesivi (i colori possono variare)



REF. 04003

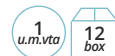
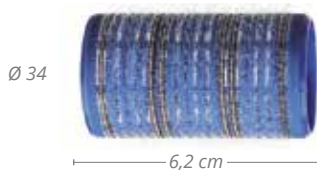

REF. 04006

Beutel mit 6 Klettwicklern extra stark
Sacchetto da 6 bigodini adesivi



REF. 04007

Beutel mit Haarnadeln
Confezione di forcine

- » Metall
- » Lang

- » Metallo
- » Lunghe

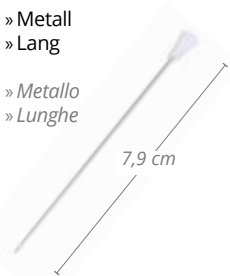

100 u

REF. 01495

- » Haarspieß
- » Forcine a spillo



36 u

REF. 00649

- » Nylon
- » Nylon



36 u

REF. 00648

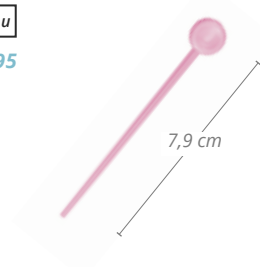

Schachtel mit Haarnadeln
Scatola per forcine

- » Nylon
- » Nylon

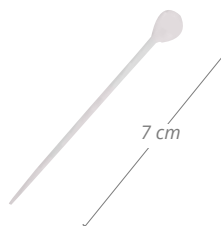

300 u

REF. 03329

Haarnetz ohne Band für die Nacht Retina senza nastro

12
u.m.vta

12
box

» Schwarz
» Nero

REF.01049/50

» Dunkelbraun
» Castano scuro

REF.01049/67



» Natürliches Kastanienbraun
» Castano naturale

REF.01049/76

» Hellbraun
» Castano chiaro

REF.01049/65



» Rosa
» Rosa

REF.01049/70

» Blau
» Blu

REF.01049/59

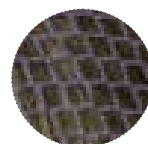

Dreieckstuch Netz zum Trocknen

Retine asciugatura triangolare

 12
u.m.vta
12
box

 » Elastisch
 » *Elastica*

90 x 72 x 72 cm

 » Großmaschig mit Band
 » *Con bordo*

80 x 70 x 70 cm



REF.01044/50 REF.01044/59

REF.01044/69 REF.01044/70



REF.01042/59 REF.01042/68

REF.01042/69

 » Ohne Band
 » *Senza bordo*

83 x 74 x 74 cm

 » Mit Band
 » *Con bordo*

83 x 74 x 74 cm



REF.01039/50 REF.01039/59

REF.01039/69 REF.01039/70



REF.01041/50 REF.01041/59

REF.01041/69 REF.01041/70

Haarnetz für die Nacht

Cuffia da notte

 12
u.m.vta
12
box

 » Mit Band
 » *Retina notte*

REF.01048/50 REF.01048/59

REF.01048/69 REF.01048/70

 » Nylon
 » Verschiedene Farben

REF.01053

 » Nylon
 » Assortimento di colori

Haarnetz für die Nacht Cuffia da notte

12
u.m.vta

60
box

» Nylon
» Nylon

REF.01539

» Nylon-Haarnetz mit Band
» Cuffia da notte in nylon con nastro

REF.01538

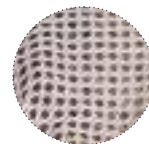
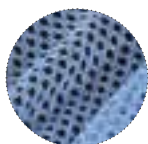

Duschhaube Cuffia doccia

» Bedruckt
» Colorata

12
u.m.vta

60
box

REF.01542

» Kunststoff
» Wiederverwendbar 3 Stück

12
u.m.vta

12
box

REF.00967

» Plastica
» Permanente 3 unità

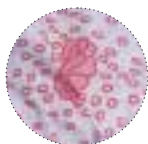

12
u.m.vta

12
box

REF.01227

REF.01227/58

» Einweg (Duschhaube)
» Monouso

200
u.m.vta

200
box

REF.01540



Beutel mit Strähnenhauben Confezione di cuffie per meches



- » Zweischichtig
- » Doppio strato

5 u

REF. 01290

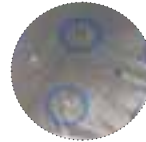

- » Schwarzer Keder
- » Bordo nero



10 u

REF.02532/50



- » Mit Haken
- » Bordo nero



50 u

REF.00973

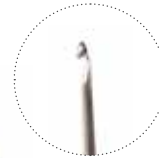

Strähnenhaube Cuffie per meches

- » Kunststoff
- » Ohne Löcher

- » Plastica
- » Senza fori



REF.00965



- » Gummi
- » Braun

- » Gomma
- » Marrone



REF. 00896



Strähnenhaube Cuffie per meches

- » Durchscheinend mit Strähnennadel
- » *Traslucida con uncinetto*



REF. 02196

- » Durchscheinend mit Strähnennadel
- » *Accessori*



REF. 03402



- » Perforiertes Silikon mit Strähnennadel
- » *Cuffie mèches in silicone, con uncinetto*



REF. 06460



- » Spezial-Silikon
- » *Silicone speciale*



REF. 03729

- » Silikon
- » *In silicone*



REF. 00897

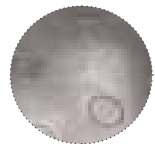

Strähnenhaube Cuffie per meches



- » Spezial-Gummi
- » Gomma speciale

REF. 00894

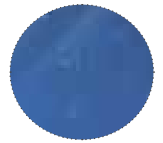

- » Gummi
- » Gomma

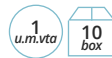

REF. 01511



- » Spezial-Gummi
- » Gomma speciale



REF. 01995



Beutel mit Strähnennadeln Sacchetto di uncinetti



» Medium
» Medium



6 u

REF. 01266

» 3 Größen
» 3 misure

3 u

REF. 01265

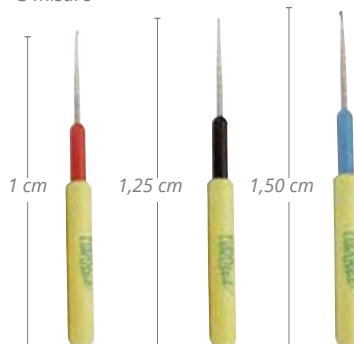

Spezial-Strähnenkamm Pettine speciale per meches



REF. 00440



Täschchen mit Strähnennadeln Sacchetto di uncinetti per meches



REF. 01966

» Doppelt
» Doppi



Strähnenkamm Metallhorn Pettine con punta in metallo per meches



REF. 00473



Strähnchen über Hauben sind eine Alternative zum Aufhellen der Haare statt durch Bleichen oder Färben.
Le meches a cuffia sono un'alternativa per dare luce ai capelli, sia sbiancandoli che con tintura.

Hauben Cuffia termica

- » Aluminium
- » Alluminio

10
u.m.vta 10
box

REF.02534



- » Föhnhauben
- » Cuffia termica per asciugacapelli

6
u.m.vta 6
box

REF.03189



- » Kunststoff "MACRO"
- » Plastica - Extra-large

12
u.m.vta 12
box

REF.00966



Haarhaube Textil Cuffia asciugamano

- » Mit Gummi und Knopf
- » Con elastico e bottone

REF. 03404

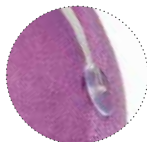

- » Ohne Gummi mit Knopf
- » Senza elastico con bottone

1
u.m.vta 10
box

REF. 04433

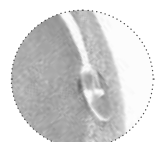

Unsichtbare Haarnetze

Retine invisibili

12
u.m.v.to

12
box

» Nylon
» Nylon

» Nylon-Dutt
» Nylon crocchia. Retine per chignon invisibili

» Natürliches Haar
» Capelli naturali



REF.01046/50



REF.01047/50



REF.01045/50

REF.01046/65

REF.01047/65

REF.01045/69

REF.01046/66

REF.01047/66

REF.01045/66

REF.01046/67

REF.01047/69

REF.01046/76



Duttkissen · Ciambelle acconciatura

Duttkissen
Ciambelle acconciatura

9 gr

Klein · Piccolo

 REF. 03001/50

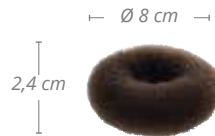
 REF. 03001/67

 REF. 03001/65

 REF. 03001/66

Mittel · Medio

 REF. 04435/50

 REF. 04435/65

 REF. 04435/66

Duttkissen**Riempimento crocchia circolare**

14 gr

Mittel/Groß
Medio/grande

REF.01453/50

REF.01453/65

REF.01453/66

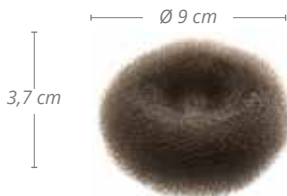
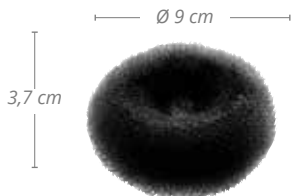

Groß · Grande

REF.04436/50

REF.04436/65

REF.04436/66

Extra groß
Extra grande

REF.04437/50

REF.04437/65

REF.04437/66

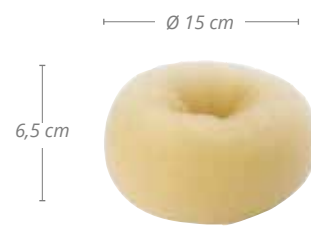

Duttkissen · Riempimenti

Duttkissen
Acconciature

14 gr



REF.01454/50



REF.01454/65



REF.01454/66

14 gr



REF. 03002/50



REF. 03002/67



REF. 03002/65



REF. 03002/66

Duttkissen mit Band
Crespo con elastico

14 gr

REF.04434/50

REF.04434/65

REF.04434/66



Duttkissen · Ripieno

Duttkissen länglich gross
Ripieno grande, allungato

52 gr

REF. 03636/50

REF. 03636/65

REF. 03636/66

Duttkissen länglich gross
Ripieno grande rotondo

20 gr

REF. 03635/50

REF. 03635/65

REF. 03635/66



Wie wird es gemacht?**Come usare?**

1. Einen Pferdeschwanz machen
1. *Fai una coda*



2. Den Zopf durch den Ring führen und mit Haarnadeln feststecken
2. *Passa la coda nel foro e fissala con le forcine*



3. Etwas Haarspray auftragen und das Haar um den Ring wickeln
3. *Applica un po' di lacca e avvolgi i capelli attorno alla ciambella*



1. Das Duttkissen auf den Kranz setzen
1. *Posizionare il ripieno sulla punta del capo*



2. Das Kissen befestigen
2. *Sosteni il ripieno*



3. Das Duttkissen mit den Haaren auf der Vorderseite abdecken und mit Haarnadeln befestigen
3. *Coprire il ripieno con i capelli della parte anteriore e fissarlo con delle forcine*

Rasiermesser und Haarschneidescheren

RASOI E FORBICI

*Haarschneidescheren, Etuis...
Forbici, astucci...*



EXCELSIOR Profi-Schere

Forbici professionali EXCELSIOR

1 u.m.vta 10 box

5,5"

REF.04900



» Schnitt
» Da taglio

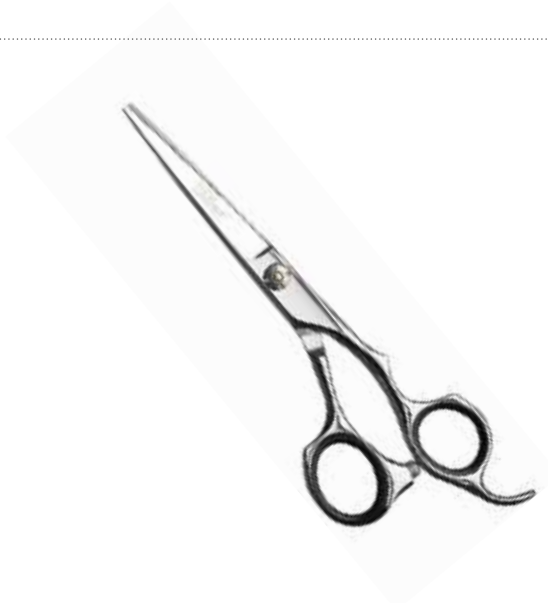

» Werkstoff: Japanischer
Stahl V610
» Härte: 63 HRC
» Rand: konvex

» Materiale: acciaio
giapponese V610
» Durezza: 63HRC

INFINITY-Schere

Forbici INIFINITY

» Werkstoff: Stahl 440C
» Härte: 59-61 HRC

» Materiale: acciaio 440C
» Durezza: 59-61 HRC

1 u.m.vta 10 box



» Beinhaltet: Öl, Ledertuch, Gummiringe und
Schraubenschlüssel

» Include: olio, anelli di gomma e chiave per
stringere

» Schnitt
» Da taglio

5,5"

REF.06976



» Schnitt
» Da taglio

6"

REF.06977



» Modellier
» Per sfoltire

6"

REF.06978





» Beinhaltet: Öl, Ledertuch,
Gummiringe und Schraubenschlüssel

» Include: olio, anelli di gomma e chiave
per stringere

AMATIST-Schere Forbici AMATIST

» Werkstoff: Stahl 440C
» Härte: 59-61 HRC

» Materiale: acciaio 440C
» Durezza: 59-61 HRC

1 u.m.vta
10 box

» Schnitt
» Da taglio

5,5"

REF.06970

» Schnitt
» Da taglio

6"

REF.06971

» Modellier
» Per sfoltire

6"

REF.06972



OASIS-Schere Forbici OASIS

» Werkstoff: Stahl 440C
» Härte: 59-61 HRC

» Materiale: acciaio 440C
» Durezza: 59-61 HRC

1 u.m.vta
10 box

» Schnitt
» Da taglio

5,5"

REF.06973

» Schnitt
» Da taglio

6"

REF.06974

» Modellier
» Per sfoltire

6"

REF.06975





- » Stahl 440
- » Rasiermesserscharf
- » Oberfläche unregelmässig
- » Hohe Härte 59,61 HRC
- » Einstellschrauben
- » Individuelles Etui

- » Acciaio 440
- » Affilatura a rasoio
- » Finitura manuale
- » Durezza 59,61 HRC
- » Viti di regolazione
- » Custodia individuale

EURO *stil*
PROFESSIONAL

SHARK Schere Forbici SHARK

- » Schnitt
- » Da taglio

5,5"

REF. 04627

- » Modellier
- » Per sfoltire

5,5"

REF. 04628



PIRATE-Schere Forbici PIRATA

- » Schnitt
- » Da taglio

5,5"

REF. 04630

DARK Schere Forbici DARK

- » Schnitt
- » Da taglio

5,5"

REF. 04629



Scherenhalter-Musterkoffer Astuccio porta-forbici

- » 6 Stück
- » 6 unità



REF. 04633



Scheren · Forbici

ATHENA-Schere
Forbici ATENEA

» Werkstoff: martensitischer Stahl 420J2
 » Härte: 56HRC

» Materiale: acciaio inossidabile 420J2
 » Durezza: 56HRC

1
u.m.vta

12
box

» Nicht enthalten: Öl, Ledertuch, Gummiringe
 und Schraubenschlüssel

» Non include: olio, anelli di gomma o chiave
 per stringere

» Schnitt
 » Da taglio

5,75"

REF.07020/68

» Modeller
 » Per sfoltire

5,75"

REF.07021/68



» Schnitt
 » Da taglio

5,75"

REF.07020

» Modeller
 » Per scolpire

5,75"

REF.07021

» Schnitt
 » Da taglio

5,75"

REF.07020/70

» Modeller
 » Per sfoltire

5,75"

REF.07021/70

**AFRODITA-Schere**
Forbici AFRODITA

Werkstoff: Stahl 440C
 Härte: 59-61 HRC

» Materiale: acciaio 440C
 » Durezza: 59-61 HRC

1
u.m.vta

12
box

» Nicht enthalten: Öl, Ledertuch, Gummiringe
 und Schraubenschlüssel

» Non include: olio, anelli di gomma o chiave
 per stringere

» Schnitt
 » Da taglio

6"

REF.07022/70

» Schnitt
 » Da taglio

6"

REF.07022





» Nicht enthalten: Öl, Ledertuch, Gummiringe und Schraubenschlüssel

» Non include: olio, anelli di gomma o chiave per stringere

ISIS-Schere Forbici ISIS

Werkstoff: martensitischer Stahl 420J2
Härte: 56 HRC

» Materiale: acciaio inossidabile 420J2
» Durezza: 56HRC



» Schnitt
» Da taglio

6"

REF.07023



» Modellier
» Per sfoltire

6"

REF.07024



» Schnitt
» Da taglio

6"

REF.07023/70



» Modellier
» Per sfoltire

6"

REF.07024/70



MINERVA-Schere Forbici MINERVA

Werkstoff: martensitischer Stahl 420J2
Härte: 56HRC

» Materiale: acciaio inossidabile 420J2
» Durezza: 56HRC



» Schnitt
» Da taglio

6"

REF.07026



» Modellier
» Per sfoltire

6"

REF.07025



» Schnitt
» Da taglio

6"

REF.07026/70



» Modellier
» Per sfoltire

6"

REF.07025/70



Scheren · Forbici

ECLIPSE-Schere
Forbici ECLIPSEWerkstoff: martensitischer Stahl 420J2
Härte: 56HRC» Materiale: acciaio inossidabile 420J2
» Durezza: 56HRC1
u.m.v.a
12
box» Nicht enthalten: Öl, Ledertuch, Gummiringe
und Schraubenschlüssel» Schnitt
» Da taglio

6"

» Modellier
» Per sfoltire

6"

» Non include: olio, anelli di gomma o chiave
per stringere

REF.07027/68

REF.07054/68

» Schnitt
» Da taglio

6"

REF.07027

» Modellier
» Per sfoltire

6"

REF.07054

» Schnitt
» Da taglio

6"

REF.07027/70

» Modellier
» Per sfoltire

6"

REF.07054/70



Stahlscheren WAVES

Forbici da taglio WAVES

1
u.m.vta

12
box

» Schnitt
» Da taglio

6"

REF.04316



» Modellier
» Per sfoltire

5,75"

REF.04317



Professionelle Schere ERGO

Forbici professionali ERGO

1
u.m.vta

12
box

» Schnitt
» Da taglio

6"

REF.04314



» Modellier
» Per sfoltire

6"

REF.04315



RUBI Profi-Schere

Forbici professionali RUBI

1
u.m.vta

12
box

» Schnitt
» Da taglio

5"

REF.04319



» Modellier
» 25 Zähne

5,5"

REF.04401

» Per sfoltire
» 25 denti



WILL-Messerklingschere mit Fingerauflage

Forbici con affilatura a rasoio con stanghetta WILL



» Schnitt
» Da taglio

5,5"

REF. 04707

» Schnitt
» Da taglio

6"

REF. 04708

» Modellier
» Per sfoltire

6"

REF. 04709



Messerschere für Linkshänder

Forbici con affilatura a rasoio per MANCINI

» Schnitt
» Da taglio

5,5"

REF.04503

» Modellier
» Per sfoltire

5,5"

REF.04504

Schere für Linkshänder

Forbici speciali per MANCINI



» Schnitt
» Da taglio

5,5"

REF.02213



Scheren COSMOS LINE
Forbici COSMOS LINE

Werkstoff: martensitischer Stahl 4cr
Härte: 51-52 HRC. - Oberfläche: matt
Abnehmbare Fingerauflage. Konvexe Klinge

» Materiale: acciaio inossidabile 4cr
» Durezza: 51-52Hrc - finitura: opaca
» Poggiadito rimovibile.



» Schnitt
» Da taglio

5,5"

REF.06815



» Schnitt
» Da taglio

6"

REF.06816



» Modellier
» Per sfoltire

6"

REF.06817

**EVOLUTE-LINE-Schere**
Forbici EVOLUTE LINE

Werkstoff: martensitischer Stahl 4CrNEW
Härte: 51-52 HRC- Oberfläche: matt
Abnehmbare Fingerauflage. Konvexe Klinge

» Materiale: acciaio inossidabile 420
» Durezza: 51-52HRC - finitura: opaca
» Poggiadito rimovibile.



» Schnitt
» Da taglio

5,5"

REF.07101



» Schnitt
» Da taglio

6"

REF.07102



» Modellier
» Per sfoltire

6"

REF.07103

**UTILE LINE-Schere**
Forbici UTILE LINE

» Werkstoff: martensitischer Stahl 4Cr
» Härte: 51-52 HRC- Oberfläche: matt
» Abnehmbare Fingerauflage. Konvexe Klinge

» Materiale: acciaio inossidabile 4cr
» Durezza: 51-52HRC - finitura: opaca
» Poggiadito rimovibile.



» Schnitt
» Da taglio

5,5"

REF.07104



» Schnitt
» Da taglio

6"

REF.07105



» Modellier
» Per sfoltire

6"

REF.07106



Scheren · Forbici

Tijeras CORVUS LINE
Forbici CORVUS LINE

- » Werkstoff: martensitischer Stahl 420
- » Härte: 51-52 HRC - Oberfläche: matt
- » Abnehmbare Fingerauflage.

- » Materiale: acciaio inossidabile 420
- » Durezza: 51-52HRC - finitura: opaca
- » Poggiadito rimovibile.



Mikroverzahnt
Micro-seghettata

- » Zubehör: Öl, zwei Fingerringe aus Gummi

» Accessori: olio, due anelli in gomma per le dita

- » Schnitt
- » Da taglio

5,5"

REF.06818



- » Schnitt
- » Da taglio

6"

REF.06819



- » Modellier
- » Per sfoltire

6"

REF.06820

**SCULPTOR LINE-Schere**
Forbici SCULPTOR LINE

- » Werkstoff: martensitischer Stahl 420
- » Härte: 51-52 HRC - Oberfläche: matt
- » Abnehmbare Fingerauflage.

- » Materiale: acciaio martensitico 420
- » Durezza: 51-52HRC - finitura: opaca
- » Poggiadito rimovibile.



Mikroverzahnt
Micro-seghettata

- » Zubehör: Öl, zwei Fingerringe aus Gummi

» Accessori: olio, due anelli in gomma per le dita

- » Schnitt
- » Da taglio

5,5"

REF.06822



- » Schnitt
- » Da taglio

6"

REF.06823



- » Modellier
- » Per sfoltire

6"

REF.06824

**LOYAL Schere**
Forbici LOYAL

- » Werkstoff: martensitischer Stahl 420J2
- » Härte: 52-54 HRC - Oberfläche: matt
- » Abnehmbare Fingerauflage.

- » Materiale: acciaio inossidabile 420J2
- » Durezza: 52-54HRC - finitura: opaca
- » Poggiadito rimovibile.

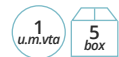

Mikroverzahnt
Micro-seghettata

- » Zubehör: Öl, zwei Fingerringe aus Gummi

» Accessori: olio, due anelli in gomma per le dita

- » Schnitt
- » Da taglio

5,5"

REF.07119



- » Schnitt
- » Da taglio

6"

REF.07120



- » Modellier
- » Per sfoltire

6"

REF.07121



NEOSTAR-Schere
Forbici NEOSTAR» Werkstoff: martensitischer Stahl 420J2
» Härte: 56 HRC» Materiale: acciaio inossidabile 420J2
» Durezza: 59-61 HRC1
u.m.vta 10
boxMikroverzahnt
Micro-seghettata» Schnitt
» Da taglio

5,5"

REF.06964

» Schnitt
» Da taglio

6"

REF.06965

» Modellier
» Per sfoltire

5,5"

REF.06966

» Schnitt
» Da taglio

5,5"

REF.06964/70

» Schnitt
» Da taglio

6"

REF.06965/70

» Modellier
» Per sfoltire

5,5"

REF.06966/70

**Rostfreie Schere SATINY**
Forbici inox SATINY» Einzelklinge mikroverzahnt
» Una lama micro-seghettata» Schnitt
» Da taglio

5,5"

REF.00725

» Schnitt
» Da taglio

6"

REF.00726

» Schnitt
» Da taglio

6,5"

REF.00727

1
u.m.vta 30
box

STAINLESS-Schere
Forbici INOX

 1 u.m.vta
 30 box

 » Modeller
 » Per sfoltire

5,5"

REF.00724

 » ModellerEffilier
 » Per sfoltire

5,5"

REF.00728

ELEGANT-Schere mit Messerschneide, schwarz und-goldener Griff
Forbici ELEGANT affilatura a rasoio, nere con manico dorato

 1 u.m.vta
 12 box

 » Schnitt
 » Da taglio

5,5"

REF.04499

 » Modeller
 » Per sfoltire

5,5"

REF.04500

BLACK Schere mit Messerschneide, matt schwarz
Forbici BLACK con affilatura a rasoio, nero satinato

 1 u.m.vta
 12 box

 » Schnitt
 » Da taglio

5,5"

REF.04501

 » Modeller
 » Per sfoltire

5,5"

REF.04502



Professionelle Schere mit legiertem Griff und seidenmatter Klinge DARK GARDEN
Forbici professionali manico in lega lama satinata DARK GARDEN

1 u.m.vta 12 box

5,5"

REF.03677

- » Modellier
- » Per sfoltire



Professionelle Schere mit Kunststoffgriff
Forbici professionali con manico in plastica



Mikroverzahnt
 Micro-seghezzata



1 u.m.vta 12 box

- » Schnitt
- » Da taglio

6"

REF. 01977

- » Modellier
- » 30 Zähne

- » Per sfoltire
- » 30 denti

6"

REF. 01978



- » Schnitt
- » Da taglio

5,5"

REF.00722

- » Schnitt
- » Da taglio

6"

REF.00723

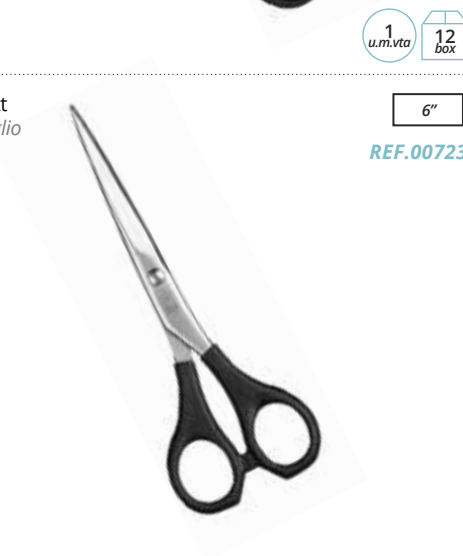
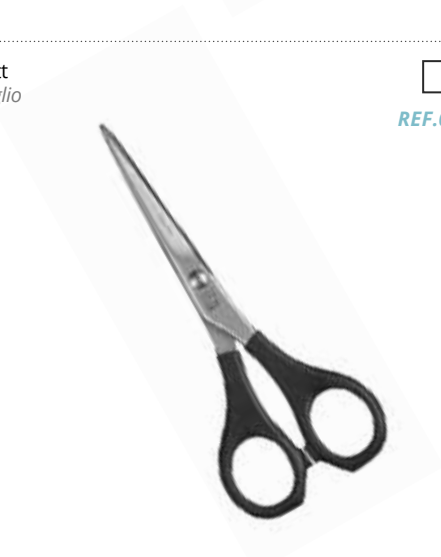

1 u.m.vta 12 box

Schere SPECIAL ACADEMY Kunststoffgriff

Forbici SPECIALI PRINCIPIANTI con manico in plastica

 Mikroverzahnt
Micro-seghettata

 1
u.m.vta
  12
box

 » Schnitt
» Da taglio

5"

REF.02807

 » Schnitt
» Da taglio

5,5"

REF.02808

 » Modellier
» 22 Zähne

6"

REF.02809

 » Per sfoltire
» 22 denti

INITIATION Schere

Forbici RAGNAR

 1
u.m.vta
  12
box

 » Schnitt
» Da taglio

6"

REF.04358

 » Schnitt
» Da taglio

6,5"

REF.04359

 » Schnitt
» Da taglio

7"

REF.04360

 » ModellierEffilier
» Per sfoltire

6,5"

REF.04361



Etui 2 Scheren Schneide/Modellierschere
Astucci da 2 forbici da taglio/sfoltire



6"

REF.06821



6"

REF.06825



Etui FLASH 2 Scheren Schneide/Modellierschere
Astucci FLASH da 2 forbici da taglio/sfoltire



5,5"

REF.07107



Kunstleder Etui Custodia in ecopelle

1 u.m.vta 12 box

Kunstleder Etui mit:

- » Messerklingen-Schere
- » Modellierschere
- » Rasiermesser wechselbar 00698
- » Professioneller Kamm 00115

Astuccio in simipelle con:

- » Forbici da taglio affilatura rasoio
- » Forbici per sfoltire
- » Rasoio lama intercambiabile 00698
- » Pettini professionale 00115



5,5"

REF.03267

Friseur-Kit für Anfänger Kit taglio studente

Etui mit:

- » 1 Schere zum Schneiden
- » 1 Modellierschere
- » 1 Rasiermesser Metall
- » Rasierklinge

Astuccio con:

- » 1 forbice da taglio
- » 1 forbice per sfoltire
- » 1 rasoio in metallo
- » Lama rasoio



6"

REF.04901

Etui 2 Scheren Schneide/Modellierschere Astucci da 2 forbici da taglio/sfoltire

1 u.m.vta 12 box

- » Glänzende Schere
- » Forbici lucide



Mikroverzahnt
Micro-seghettata

5,5"

REF.03682



Scherenkoffer für 20 Stück (leer)
 Valigetta porta-forbici per 20 unità (vuota)



REF.04634



Behälter für Scheren
 Contenitore per forbici



REF.04740



Scheren-Aussteller
 Espositore per forbici



REF.04074

» Plexiglas
 » Plexiglass



Haarschnitt
 Rasoio

» Eine Klinge
 » Una lama

REF.00961



» Zwei Klingen
 » Due lame



REF.00962



Schachtel 100 Einweg Rasierklingen Pollié
 Caonfezione di 100 rasoi monouso Pollié'

» Mit Schutz
 » Con protezione



REF.02480



10 Schachtel mit je 10 Profi-Messern Eurostil Styling Scatola di 10 confezioni, di 10 lame styling



Das Messerblatt ist aus hochwertigem, platinhaltigem Inox-Stahl und daher langlebig. Die Fläche ist mit Teflon behandelt, was eine sanfte und komfortable Rasur ermöglicht. Die Plastikbox schützt das Messer.

La lama è realizzata in acciaio inossidabile di alta qualità con una placcatura in platino, che rende più liscia la rasatura e dà una sensazione di rasatura più confortevole.



Ersatzklingen: 01498 -04073-04075

Ricambio per rasoi: 01498 -04073- 04075



REF.07123

Preis von 10 Kartons mit 10
Blatt: 26 €
Spender von 10 Blatt 2,6 €

» Mit Teflon behandelt
» Con rivestimento in teflon

Prezzo 10 scatole da 10 fogli:
26€

Dispenser da 10 fogli 2,6€

Rasiermesser Rasoi

» Rasiermesser Silber aus Metall
» Rasoio argento metallizzato



REF.02535/54



» Metallicblau
» Mit Schutz



REF.04073

» Kunststoffgriff
» Mit Schutz



REF.04075

» Silbermetallic
» Argento metallizzato

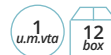

REF.01498

» Blu metallizzato
» Con protezione

» Manico in plastica
» Con protezione

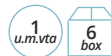

FEATHER-Klingen
Rasoi FEATHER

REF.04386

REF.04387

**Schachtel mit 10 Klingen STYLING RAZORS · Confezione da 10 lamette STYLING RAZORS**

REF.07159



REF.04388



REF.04389

Ersatzklingen: 04386 - 04387
Ricambio per rasoi: 04386 - 04387**FEATHER NAPE RAZOR Messer**
Rasoi FEATHER NAPE RAZOR

REF.04394

Spender mit 20 Klingen
Dispenser 20 lamette**Professional PB-20**

REF.04391

Schachtel mit 10 Klingen NAPE RAZOR
Confezione da 10 lamette
NAPE RAZOR

REF.04395



Klebe-extensions und haarteile

EXTENSION
ADESIVE

*Haarteile , Extensions , Klammern,
Ringe, Kleber, Lösungsmittel...*

Extension, clips, colla



Remy Echthaar Extensions

Extension di capelli naturali remy

1 u.m.vta
10 box

10 cm



50 cm

» Haargewicht ca. 98-100 Gramm

» Peso extension 98-100 grammi circa.



» Schwarz
» Neri

N°1

REF.03354



» Rötlich
» Rossastro

N°30M

REF. 03363



» Kastanienbraun
» Castano ramato

N°10

REF.03357



Remy Echthaar Extensions mit Clip

Extension a retina di capelli naturali remy con clip

1 u.m.vta
6 box

15 cm



50 cm

» 15 cm breiter Haarteil mit 3 Clips und 50 cm lang
» Remy Haar
» Jede Klammer ist 2,8 mm breit
» Gewicht: etwa 20 g (mit Klammern)

» Extension larga 15 cm con 3 clip e lunga 50 cm
» Capelli remy
» Ogni clip è lunga 2,8 mm
» Peso: 20 gr circa (con clip)



x3

» Rötlich
» Rossastro

N°30M

REF.03650

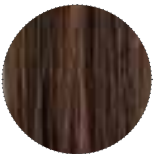

» Castaño Rötlich
» Castano rossastro

N°30

REF.03651



» Kastanienbraun
» Castano ramato

N°10

REF.03644



Keratin-Extensions

Extension cheratina

1 u.m.vta
6 box



50 cm

» Pack 20 Extensions 50 cm lang
» Remy Haar
» Keratin
» Gewicht: ca. 14 gr.

» Confezione da 20 extension di 50 cm di lunghezza
» Capelli remy
» Cheratina
» Peso: 14 gr. circa

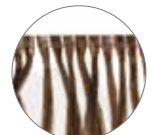

» Kastanienbraun
» Castano ramato

N°10

REF.03369



» Dunkles Kupferbraun
» Castano scuro ramato

N°32

REF.03377

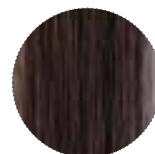

Dose mit gravierten Alu-Ringen
Confezione ring ricambi per ciocche in alluminio

100 Stück für Extensions
 100 unità per extension



» Schwarz
 » Neri

N°1

REF.02911



» Dunkelbraun
 » Castano scuro

N°3

REF.02912



» Mittelbraun
 » Castano medio

N°5

REF.02913



» Dunkelblond
 » Biondo scuro

N°1

REF.02914



» Platin-Blondine
 » Biondo platino

N°3

REF.02915



» Bordeaux
 » Bordeaux

N°5

REF.02927



Dose mit gravierten Alu-Ringen
Barattolo ring ricambi per ciocche in alluminio

1000 Stück für Extensions
 1000 unità per extension



» 68 gr
 » 68 gr

» Schwarz
 » Neri

N°1

REF.02867



» Dunkelbraun
 » Castano scuro

N°3

REF.02868



» Mittelbraun
 » Castano medio

N°5

REF.02869



» Dunkelblond
 » Biondo scuro

N°1

REF.02870



» Platin-Blondine
 » Biondo platino

N°3

REF.02871



» Bordeaux
 » Bordeaux

N°5

REF.02921



Packung mit Clips für große Extensions 3,2 cm

Sacchetto di clips per extension grandi 3,2 cm

» Schwarz
» Nero

1 u.m.vta
20 box

50 u

REF.02924/50

12 u.m.vta
12 box

4 u

REF.03269/50

» Braun
» Marrone

1 u.m.vta
20 box

50 u

REF.02924

12 u.m.vta
12 box

4 u

REF.03269



3,2 cm



3,2 cm

» Silber
» Argento

1 u.m.vta
20 box

50 u

REF.02924/54

12 u.m.vta
12 box

4 u

REF.03269/54

» Blond
» Biondo

1 u.m.vta
20 box

50 u

REF.02924/66

12 u.m.vta
12 box

4 u

REF.03269/66



3,2 cm



3,2 cm

Packung mit Clips für 2,8-cm Extensions-

Sacchetto di clips per extension 2,8 cm

» Schwarz
» Nero

1 u.m.vta
20 box

50 u

REF.03306/50

12 u.m.vta
12 box

4 u

REF.03270/50

» Braun
» Marrone

1 u.m.vta
20 box

50 u

REF.03306

12 u.m.vta
12 box

4 u

REF.03270



2,8 cm



2,8 cm

» Silber
» Argento

1 u.m.vta
20 box

50 u

REF.03306/54

12 u.m.vta
12 box

4 u

REF.03270/54

» Blond
» Biondo

1 u.m.vta
20 box

50 u

REF.03306/66

12 u.m.vta
12 box

4 u

REF.03270/66



2,8 cm

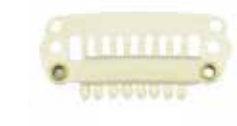

2,8 cm

Packung mit Clips für 2,2-cm Extensions Sacchetto di clips per extension 2,2 cm

» Schwarz
» Nero

1 u.m.vta 20 box

50 u

REF.03307/50



— 2,2 cm —

12 u.m.vta 12 box

4 u

REF.03271/50

» Braun
» Marrone

1 u.m.vta 20 box

50 u

REF.03307



— 2,2 cm —

12 u.m.vta 12 box

4 u

REF.03271

» Silber
» Argento

1 u.m.vta 20 box

50 u

REF.03307/54



— 2,2 cm —

12 u.m.vta 12 box

4 u

REF.03271/54

» Blond
» Biondo

1 u.m.vta 20 box

50 u

REF.03307/66



— 2,2 cm —

12 u.m.vta 12 box

4 u

REF.03271/66

Klebstoff zum Fixieren von Haarteilen Colla per fissare le extension sui capelli

» Auf Basis von Naturlatex
» Farbe des Klebstoffs: Dunkel

50 ml

REF.03176/50

» A base di lattice naturale
» Colore adesivo scuro



» Auf Naturlatex basierend
» Farbe des Klebstoffs: Weiß

50 ml

REF.03176/58

» A base di lattice naturale
» Colore adesivo bianco



Auf Naturlatex basierend Farbe des Klebstoffs: Weiß Solvente per extension alla cheratina

1 u.m.vta 20 box

150 ml

REF.03164



Haarteile mit Lösungsmittelkleber Solvente adesivo per extension

1 u.m.vta 20 box

150 ml

REF.03177



Packung 12-Scheiben für extensions
Sacchetto da 12 dischi per extension

1 u.m.vta
60 box

12 u

REF.02582



Packung mit Ringnadeln
Confezione di uncini per anelli

1 u.m.vta
5 box

12 u

REF.02873



Zange für extensions
Pinze per extension

- » Zweifarbiger Griff
- » Manico bicolore

1 u.m.vta
60 box

REF.02872



Spezial-Zange extensions
Pinze speciali per extension

- » Mit Ring
- » A molla

1 u.m.vta
60 box

REF.02581



Farbmuster für extensions
Campionario extension colorate

1 u.m.vta
20 box

REF.03378



Auswahl extensions
Kit per extension

1 u.m.vta
12 box

REF.04208



12

Verschiedenes

VARI

*Handtücher, Koffer,
Sprays, Watte...*

*Asciugamani, spruzzini, valigie
e trolley da la lavoro*



1 kg Watte in Rollen
1 Kg di cotone in rotoli

- » 9 Schnitte von 3,5 cm (einschließlich Spitzen)
- » 9 tagli da 3,5 cm (punte incluse)

REF. 00964 REF. 00964/00

Anonym
Senza marca

- » Breite
- » 4 Schnitte von 8 cm (einschließlich Spitzen)
- » Largo
- » 4 tagli da 8 cm (punte incluse)

REF. 04290



- » Gefaltet
- » 9 Schnitte von 3,5 cm (einschließlich Spitzen)
- » Piegato
- » 9 tagli da 3,5 cm (punte incluse)

REF. 04288



Schwarze Friseurertasche Borsa da parrucchiere nera



REF. 02517

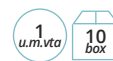

REF. 02596

Werkzeugtasche schwarz Borsa porta utensili



REF. 02516



Tasche - Rucksack für die Akademie Borsa - zaino scuola



Bequemer schwarzer Textilkoffer mit Aufhänger und Riemen zum Tragen als Rucksack. Sie hat einen Griff zum Tragen als Handgepäckstück und auch einen Schultergurt. Enthält 2 Fächer und einen Kartenhalter.

Comoda borsa in stoffa nera. Ha una presa per portarla come bagaglio a mano e anche una tracolla per portarla a spalla. Include 2 scomparti e un portata-carte.

REF. 07018



Aluminium-Koffer Valigie in alluminio

Alle Koffer werden leer verkauft
Tutte le valigie sono vuote



- » Für Utensilien, klarer Innenraum und 4 Ablagen
- » Per strumenti, interno spazioso composto da 4 scomparti



REF.03598

- » Für Utensilien, innen 6 Fächer und 4 Ablagen
- » Per strumenti, interno composto da 6 scomparti 4 vassoi



REF.03599



REF. 02319

REF.02318



REF.04307



Aluminium-Koffer
*Valigie in alluminio*Alle Koffer werden leer verkauft
Tutte le valigie sono vuote

REF.02317

» Für Utensilien
» Porta strumenti

REF.01497



REF.01492



REF.04306

Schwarzer PVC-Koffer
*Valigia in PVC nera*Alle Koffer werden leer verkauft
Tutte le valigie sono vuote

REF.02925

Melamingrauer Profi-Koffer (leer)
Valigia professionale grigia (vuota)

REF.02593

Trolley-Koffer
Valigia trolley

REF.02523/50



REF.02929/50



REF.02929



Trolley-Koffer aus Kunstleder für Friseure
Valigia trolley in similpelle per parrucchiere

Alle Koffer werden leer verkauft
 Tutte le valigie sono vuote

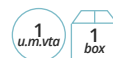

REF.04308



Trolley-Koffer "COCODRILO" aus Kunstleder für Friseure
Valigia trolley "COCCODRILLO" in similpelle per parrucchiere

Alle Koffer werden leer verkauft
 Tutte le valigie sono vuote



REF.06136

- » Es besteht aus: 3 großen Fächern mit je 2 Fächern oben. Das Tablett hat einige Fächer, in denen Utensilien untergebracht werden können.
- » Mit montierbaren Rädern lässt er sich bei Bedarf bequemer und einfacher bewegen.

» Composta da: 3 ampi scomparti con 2 vassoi ciascuno nella parte superiore. Il vassoio ha scomparti per riporre gli strumenti.

» Con ruote rimovibili, per essere spostata più comodamente e facilmente, a seconda delle necessità.



Friseur-Tasche mit Rädern Trolley da lavoro, parrucchiere

» Mit einer Metallstruktur, die es ermöglicht, den Koffer als Sitz zu verwenden
» Con struttura in metallo che permette di utilizzare la valigia come seduta

Alle Taschen werden leer verkauft
Tutte le valigie sono vuote



Inklusive Toilettentasche (leer)
Beauty case (vuoto) incluso



REF.04402/50



REF.04402/80

Trolley-Koffer Valigia trolley

TALLE Taschen werden leer verkauft
Tutte le valigie sono vuote



REF.03814/68



REF.03814/50

4-teiliger Koffer Valigia a 4 blocchi

Alle Taschen werden leer verkauft
Tutte le valigie sono vuote



- » 3-teiliger Koffer. Die ersten 2 an der unteren Basis haben 4 Beine und die vierte hat 5 Räder
- » Innenseite mit schwarzer Schaumstoffbeschichtung
- » Höhenverstellbarer Griff je nach Körperanforderungen
- » 1. und 2. Kofferteil: ca. 24,5 x 21,5 x 9 cm hoch, inkl. 2 Seitenteiler mit Leitschienen, um den Raum je nach Bedarf anzupassen.
- » 3. Kofferteil: ca. 24,5 x 21,5 x 35 cm hoch, völlig lichtdurchlässig.
- » 4. Kofferteil: ca. 24,5 x 21,5 x 18 cm hoch, völlig lichtdurchlässig.

- » Valigia a 4 blocchi. I primi 2 alla base inferiore hanno 4 gambe e il quarto ha 5 ruote
- » Interno foderato in gommapiuma nera
- » Manico regolabile in altezza in base alle esigenze del corpo
- » 1° e 2° blocco: Misure approssimative 24,5 x 21,5 x 9cm di altezza, comprende 2 divisori laterali con guide per adattare lo spazio a seconda delle esigenze.
- » 3° blocco: Misure approssimative 24,5 x 21,5 x 35cm di altezza, completamente aperto
- » 4° blocco: Misure approssimative 24,5 x 21,5 x 18cm di altezza, completamente aperto



Koffertasche zweistöckig aus Nylon mit Rädern Valigia doppia in nylon con ruote



Die obere Koffertasche kann in ein Handgepäck umgewandelt werden, das mit einem Schulterriemen versehen ist. Er hat zwei seitlich verschiebbare Innenfächer, der Innenraum ist breit und der untere Teil ist abnehmbar und kunststoffbeschichtet, um die Reinigung des Koffers zu erleichtern. Es hat auch eine Außentasche auf der Rückseite. Das Untergehäuse mit Rädern hat eine kunststoffbeschichtete Innenseite, ist zur leichten Reinigung abnehmbar und wird mit einer Bürstenhalterdecke geliefert, die mit einem Klettverschluss befestigt wird. Diese Decke ist austauschbar zwischen die Oben- und Unter-Gehäuse. Es verfügt über 8 Schubladen zur Lagerung und Trennung kleiner Produkte. Es hat auf jeder Seite eine Tasche. Jedes Abteil hat 4 Schubladen integriert, die in einem Stück verbunden sind, sie sind herausnehmbar.

REF.04943

La valigia può essere convertita in un bagaglio a mano che viene fornito con una tracolla. Ha due vassoi interni che possono essere spostati ai lati, l'interno è spazioso e la parte inferiore è estraibile e laminata in plastica per facilitare la pulizia della valigia. Anche nella parte posteriore ha una tasca esterna. La valigia inferiore con ruote ha la parte interna plastificata, è estraibile per facilitare la pulizia e viene fornita con un porta spazzole che si fissa tramite velcro. Questo porta spazzole può essere scambiato tra la valigia superiore e quella inferiore. Dispone di 8 cassetti per riporre e separare piccoli prodotti. Ha una tasca su ogni lato. Ogni colonna integra 4 cassetti uniti in un unico blocco e che sono rimovibili.



Trolley-Koffer mit 2 Kästen
Valigia trolley a 2 blocchiAlle Koffer werden leer verkauft
Tutte le valigie sono vuote

Der Trolley-Koffer von Pollié wurde auf der Grundlage einer Struktur mit zwei modifizierbaren Stockwerken geschaffen, die es den Fachleuten erleichtern soll, ihre Friseur-, Make-up- oder Kosmetikutensilien unterzubringen. Der obere Teil des Gehäuses besteht aus drei herausnehmbaren Schubladen. Jede von ihnen ist in drei Fächer unterteilt.

In einem von ihnen finden Sie zwölf kreisförmige Räume, in denen der Nagellack aufbewahrt werden kann, so dass er sich nicht auslaufen kann, was seinen Transport in völliger Sicherheit erlaubt. Ebenso kann das Innere des Oberteils nach Ihren Bedürfnissen modifiziert werden, indem die Struktur der Fächer variiert wird. Seine 2 in 1-Funktion schließlich ermöglicht es Ihnen, ein Handgepäck zu haben, oder Sie ziehen es vor, es an die Schulter zu hängen, dank seines Nylonriemens. Im unteren Teil des Koffers befindet sich eine herausnehmbare Tablett mit einer Option von 4 Fächern, die dank der Trennwände auch modifiziert werden können. Der untere Korpus mit großem Fassungsvermögen im Inneren bietet Ihnen die Möglichkeit eines leichteren Transports, da er in einen kleineren Koffer umgewandelt werden kann, in den ein Deckel und ein Spiegel integriert sind. Die Räder sind mit Hilfe der Hakenlasche tauschbar. Der Wagen hat zwei Rollen und zwei Ersatzschlüssel.

Il trolley Pollié è concepito sulla base di una struttura a 2 blocchi modificabili ed è studiato per facilitare ai professionisti la disposizione dei propri strumenti da parrucchiere, trucco o cosmetici.

La parte superiore del trolley è composta da tre vassoi rimovibili. Ognuno di essi è diviso in tre scomparti.

A sua volta, in ognuno di essi, troverai dodici scomparti circolari pensati per riporre gli smalti per unghie affinché rimangano fermi facilitando così il loro trasporto in totale sicurezza. Inoltre, l'interno del blocco superiore può essere modificato in base alle proprie esigenze, variando la struttura degli scomparti. Infine, la sua funzione 2 in 1 ti permetterà di avere un bagaglio a mano o se preferisci puoi portarlo a tracolla grazie alla sua cintura in nylon.

La parte inferiore della valigia ha un vassoio estraibile con possibilità di creare 4 scomparti anch'essi modificabili grazie ai divisori. La parte inferiore del blocco, con una grande capacità interna, ti darà la possibilità di effettuare un trasporto più leggero, poiché può essere trasformata in una valigia più piccola con anta e specchio incorporato. Le ruote sono intercambiabili tramite la linguetta di aggancio. Il trolley ha due serrature e due chiavi di scorta

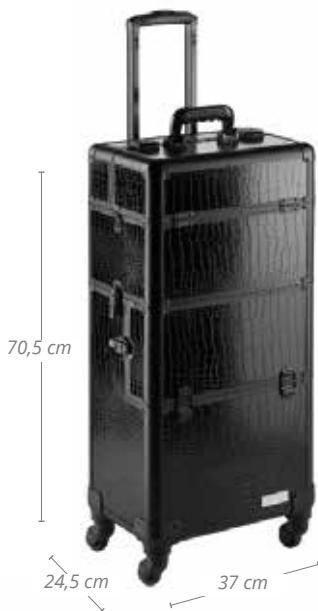

REF.04939/50



REF.04939



Friseurtasche schwarz Porta strumenti nero

Alle Friseurtaschen werden leer verkauft
Tutti i porta strumenti sono venduti vuoti



REF. 01238



REF. 01236



REF. 01237



REF. 02515



REF. 02513



REF. 02514



Friseur Taschen Friseurgürtel
Cintura porta strumenti

Alle Friseur Taschen werden leer verkauft
 Tutti i portautensili vengono venduti vuoti

- » Mit 5 kombinierten Taschen
- » Con 5 tasche combinabili

1 u.m.vta 48 box

REF.03622



1 u.m.vta 48 box

REF.04310

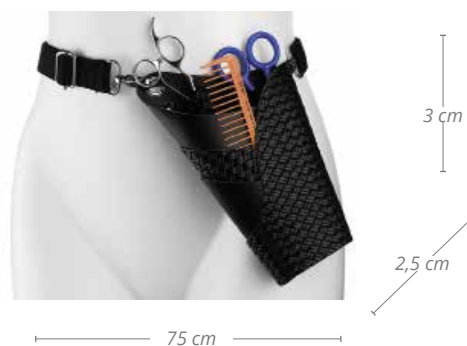

Box mit 50 Stück Gesichtsschutz FACEPRO
Confezione da 50 unità protezione viso FACEPRO

Exklusiv-Verkaufsartikel in SPANIEN, PORTUGAL UND ANDORRA
Articoli in vendita esclusiva IN SPAGNA, PORTOGALLO E ANDORRA



REF. 04480

Organisches Material
Bio



REF. 04223

KEIN Organisches Material
NO Bio



**Face pro schützt das Gesicht vor abgeschnittenen Haaren, Haarspray,
heißer Luft aus dem Fön, Farbstoffen...**
**Face pro protegge il viso dai capelli tagliati, dalla lacca, dall'aria calda dell'asciugacapelli,
dalle tinture...**

Sortierkasten (leer)
Organizer (vuoto)

REF.04722

» Magnetisch
» Magnetizzato

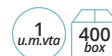

REF.04309

**Visitenkartenbox aus Aluminium**
Porta biglietti da visita in alluminio

REF.02470

Taschen-Aufhänger/ Haken
Gancio appendiabiti

REF.03304



Utensilientasche aus Silikon
Portautensili in silicone1
u.m.vta 48
box» Mit Saugnäpfen
» Con ventose1
u.m.vta 6
box

REF.04370

REF.04404/68



REF.04404/50

**Gesichtsschutz**
Visiera20
u.m.vta 20
box**Spiegel**
Specchi1
u.m.vta 12
box

REF.00287

REF.01233

**Spiegel**
Specchi1
u.m.vta 12
box

REF.00286

1
u.m.vta 6
box

REF.02538/54

1
u.m.vta 1
box

REF.03626



Perückenträge**Testina porta parrucca**

Ø 59



REF. 03489



REF. 04367



Ø 16 - 17

» Styropor
» Polistirolo**Perückenträge****Porta parrucca**

REF. 00982

» Unterwegs
» Trasportabile

Ø 17,5

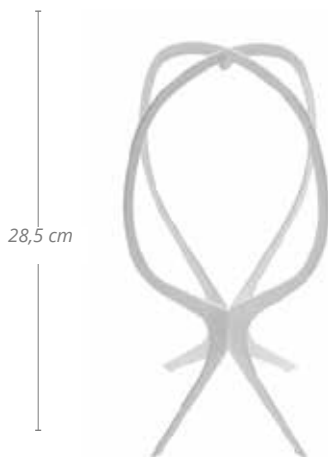

REF. 00982/50

Sprüflasche STIL
Spruzzino STIL

260 ml

» Transparent
» Transparente

REF. 02683



Farbige Sprühflasche transparent
Spruzzino trasparente colorato

330 ml
● ● ●
REF.00959

300 ml
● ● ●
REF.01372

» Rund
» Rotondo

300 ml
● ● ●
REF.01484

300 ml
● ● ●
REF.01663

**Sprühflasche 360°**
Atomizzatore spray 360°

300 ml
REF.04731

Desinfektionssprüher 360°
Spray disinfettante continuo

NEW

300 ml
REF.07247



- » Kontinuierliches Sprühen: Mit einem einzigen Druck wird das Wasser vom Anfang bis zum letzten Tropfen gleichmäßig und fein mit dem gleichen Druck gesprüht.
- » 360°: Kann aus allen Winkeln verwendet werden, auch verkehrt herum. Feines, nebelartiges Spray, das das Wasser gleichmäßig über alle Haare verteilt
- » Fassungsvermögen: 300 ml nachfüllbar.
- » Festes Druckvolumen: 1,25 ccm kontinuierlich.
- » Vermeiden Sie Ermüdung der Hände im Vergleich zu Standardsprays. Ohne umweltschädliche Gase.

- » *Spruzzo continuo: con una sola pressione spruzza l'acqua in modo uniforme e fine con la stessa pressione dall'inizio fino all'ultima goccia.*
- » *360°: può essere utilizzato da tutte le angolazioni, anche sottosopra.*
- » *Nebulizzazione sottile: tipo di nebulizzazione che distribuisce l'acqua in modo uniforme su tutti i capelli.*
- » *Capacità: 300 ml ricaricabili. Volume di pressione fisso: 1,25 cc continuo.*
- » *Evita l'affaticamento della mano rispetto agli spruzzatori standard Senza gas inquinanti.*



Sprühflasche Aluminium
Spruzzino in alluminio» Innen lackiert
» Interno laccato

23,5 cm



280 ml

REF.01384

» Neutral
» Neutro

280 ml

REF.01384/02

**Stellkasten mit 30 Aluminium- Sprühflaschen**
Espositore 30 spruzzini in alluminio

280 ml

REF.01465

280 ml

REF.01465/02

» Eurostil
» Eurostil» Neutral
» Neutro**Zerstäuber aus Kunststoff**
Spruzzino in plastica» Mit Anhänger
» Con gancio

130 ml

REF.03401

» Japanisch schwarz
» Nero giapponese

300 ml

REF.04377



Handtuch aus 100% Baumwolle
Asciugamano 100% cotone

380 gr

REF. 02947/50

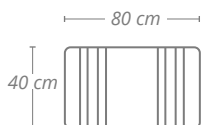

REF. 02947/58

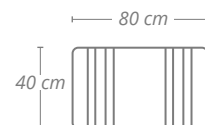

REF. 02901/50

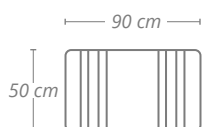

REF. 02901/58

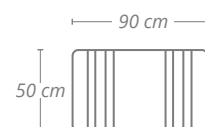

- » Bleichmittelbeständig
- » Resistente alla candeggina

REF. 04953/50

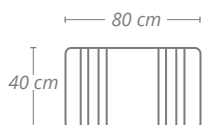

NEW

REF. 06829/50

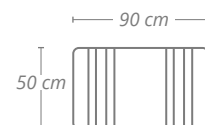

Hydroalkoholisches Gel mit Aloe Vera

Gel idroalcolico con Aloe Vera



NEW

1 u.m.vta
40 box

100 ml

REF.07245

NEW

1 u.m.vta
20 box

500 ml

REF.07235

NEW

1 u.m.vta
12 box

1 L

REF.07267

NEW

1 u.m.vta
2 box

5 L

REF.07268



Hydroalkoholische Lösung

Soluzione idroalcolica

NEW

1 u.m.vta
63 box

100 ml

REF.07174

NEW

1 u.m.vta
23 box

500 ml

REF.07175

NEW

1 u.m.vta
7 box

1 L

REF.07259

NEW

» Mit dosierpumpe
» Con pompa dosatrice1 u.m.vta
7 box

1 L

REF.07213



Hydroalkoholisches Gel Gel idroalcolico



NEW

REF.07215



Alkohol 96° Alcol 96°



NEW

REF.07217



Dosierpumpe gel 1l / 500 ml Pompa dosatrice gel 1l / 500 ml

Ideal zum Mischen mit Wasser und zum Befüllen des Zerstäubers für die Reinigung und Desinfektion von Oberflächen

Ideale per miscelare con acqua e spruzzare per pulire e disinfettare le superfici



REF.RE07267



Handdesinfektionsmittel in sprayform Igienizzante per le mani in spray

Zur Desinfektion der Hände ohne Notwendigkeit von Wasser und Seife. Hält die Hände jederzeit sauber und schützt sie vor äußeren Einflüssen. Hoher Gehalt an Glycerin, das der Haut Feuchtigkeit spendet. AUSSCHLIESSLICH AUF GESUNDER HAUT VERWENDEN.

Per igienizzare le mani senza bisogno di acqua e sapone. Formulato per mantenere le mani pulite in ogni momento, proteggendole da agenti esterni. Alto contenuto di glicerina che funge da idratante per la pelle. USO ESCLUSIVO SU PELLE SANA.

NEW

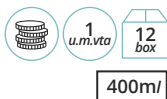

REF.07231



Verkaufsträger 120 sachets mit desinfektionstuch Espositore 120 bustine con salvietta igienizzante

Reinigung ohne Wasser. Für eine gesunde und saubere Haut überall

Pulizia senza acqua. Per una pelle sana e pulita ovunque



REF.07236

NEW



Artikel, die ausschließlich in Spanien verkauft werden
Articoli in vendita esclusiva IN SPAGNA

Antiseptikum Daromix GH
Antisettico Daromix GH

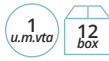

500 ml

REF.06200



- » AEMPS-Registrierungsnummer: 905-DE5
- » Wasser-alkoholisches Antiseptikum zur hygienischen Händedesinfektion durch Reibung
- » Wissenschaftlich garantierte Wirksamkeit
- » Breites Biozidspektrum ab 30 sec
- » Hypoallergene Formel
- » Bewahrt die Hautfeuchtigkeit
- » Keine Hautreizung
- » Trocknet schnell
- » Wirksam als: Bakterizid, Levurizid, Viruzid, Mikrobakterizid

- » Numero di registrazione AEMPS: 905-DE5
- » Antisettico idroalcolico per la disinfezione igienica delle mani per sfregamento
- » Efficacia scientificamente garantita
- » Biocida ad ampio spettro a partire da 30 sec
- » Formula ipoallergenica
- » Preserva l'idratazione della pelle
- » Non irritante per la pelle
- » Asciuga velocemente
- » Efficace come: battericida, lieviticida, viricida, microbattericida

Desinfektionsmittel Limoseptol
Disinfettante Limoseptol



50 ml

REF. 06151



1 L

REF.06150



- » Dosis: 100 ml in 10 l Wasser
- » Zeit: 15 min
- » AEMPS-Registrierungsnummer: 47-DE5
- » Hochwertiges Produkt, das ausschließlich für die Hygiene, Reinigung und Desinfektion von professionellem Salonzubehör entwickelt wurde
- » Waschmittelwirkung - Breites Spektrum
- » Biologisch abbaubar - phosphatfrei und FORMOLFREI
- » Keimtötende und desinfizierende Wirkung gegen: Bakterien, Hefen und Pilze

- » Dose: 100 ml in 10 l d'acqua
- » Tempo: 15 minuti
- » Numero di registrazione AEMPS: 47-DE5
- » Prodotto di alto livello sviluppato esclusivamente per l'igiene, la pulizia e la disinfezione degli utensili professionali nei centri estetici
- » Azione detergente - Ampio spettro
- » Biodegradabile - Senza fosfati e senza FORMOLO
- » Efficacia germicida e DISINFETTANTE contro: batteri, lieviti e funghi

Desinfizierende fussmatte Tappetino disinfectante per scarpe

1
u.m.vta

12
box

REF.07234

Extra flache Fußmatte mit nur 1 cm Höhe zur Verhinderung von Ausrutschen, hergestellt aus Polypropylen auf einer Gummiunterlage, enthält ionisiertes Aluminium. Maße: 60 cm Breite x 40 cm Länge x 1 cm Höhe/Dicke.

Verwendung: die Matte auf eine ebene, waagerechte Fläche legen, etwa 700 ml Desinfektionsflüssigkeit auf die Ablage auftragen. Es ist ratsam, einen Fußabtreter auf die Ablage zu legen, um die Schuhe des Kunden zu trocknen.

Tappetino extra piatto alto solo 1 cm per evitare inciampi, realizzato in polipropilene su base in gomma e contenitore in alluminio ionizzato. Misure: 60 cm di larghezza x 40 cm di lunghezza x 1 cm di altezza/spessore.

Modo d'uso: posizionare il tappetino su una superficie piana e livellata, applicare circa 700ml di liquido disinfectante sul vassoio. Si consiglia di posizionare un tappetino accanto al vassoio per asciugare le scarpe del cliente.

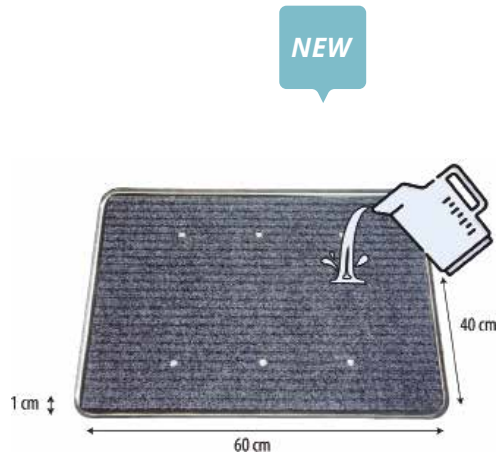

Anti-fog Schutzbrille Occhiali protettivi antivapore

1
u.m.vta

50
box

REF.07256

- » Schutz zur Prävention gegen Infektionen: schützt wirksam gegen Spritzer,
- » Kies usw.
- » Verwendungsort: jeder Ort, an dem Augenschutz erforderlich ist.
- » Innovatives, komfortables Design. Passt sich perfekt an jede Kopfform und Kopfgröße an.
- » Kann gleichzeitig mit Ihrer normalen Brille verwendet werden.
- » EG-Zertifizierung
- » Material: Kunststoff

- » *Protezione per prevenire le infezioni: proteggere efficacemente da schizzi, schegge, ecc.*
- » *Luogo di utilizzo: qualsiasi luogo in cui è richiesta la protezione degli occhi.*
- » *Confortevole design innovativo. Si adattano perfettamente a qualsiasi forma e dimensione della testa.*
- » *Possano essere utilizzati contemporaneamente agli occhiali da vista.*
- » *Certificato CE.*
- » *Materiale: plastica*



Beutel 100 schuhüberzüge Copri-scarpe 100 unita

1
u.m.vta

50
box

REF.07211

- » Einweg
- » Plastik
- » Monouso
- » Plastico



Automatischer wandgelspender mit tablet

Erogatore automatico di gel da parete con vassoio



Automatischer tisch-gel-spender

Erogatore automatico di gel da parete



Automatischer gelspender mit sockel

Erogatore di gel automatico con treppiede



Manueller wandspender

Erogatore manuale da parete



- » Werkstoff: ABS
- » Pumpentyp: Gel-Tropf
- » Stromversorgung: 4 Batterien (LR14 Größe C)
- » Erkennungsabstand: 6-10 cm.
- » Abgabemenge: 0,8-1 ml einstellbar

- » Materiale: ABS
- » Tipo di pompa: erogazione di gocce di gel
- » Alimentazione elettrica: 4 batterie (LR14 tipo C)
- » Distanza di rilevamento: 6-10 cm.
- » Uscita: 0,8-1 ml regolabile

Besen aus Gummi

Scope di gomma

- » Mit Borsten
- » Con linguetta



4
u.m.vta

16
box

REF.01223



5
u.m.vta

20
box

REF. 01285/50

- » Die leicht zu reinigenden und langlebigen Borsten sind so konstruiert, dass sie den Staub mitreißen, ohne ihn anzuheben, was sie für Allergiker ideal macht, da sie eine saubere Umgebung begünstigen.

- » Facile da pulire e di lunga durata, l'efficienza del design dei suoi denti riesce a trascinare la polvere senza sollevarla, rendendola ideale per chi soffre di allergie.

5
u.m.vta

20
box

REF.02420



Besenstiel

Manico di scopa

- » Leicht zu reinigen und langlebig
- » Kunststoffhalter
- » Ideal für alle Arten von Böden

- » Facile da pulire e di lunga durata
- » Gancio in plastica

12
u.m.vta

12
box

REF.01131

- » Extra Teleskop - Speziell für Parkett
- » Telescopico extra

10
u.m.vta

10
box

REF.01365









www.eurostil.com



*C/Ciudad de Asunción 56 · Barcelona 08030 (Spain)
Tel. +34 93 274 07 84 · Fax. +34 93 311 89 56
ventas@eurostil.com · export@eurostil.com*